

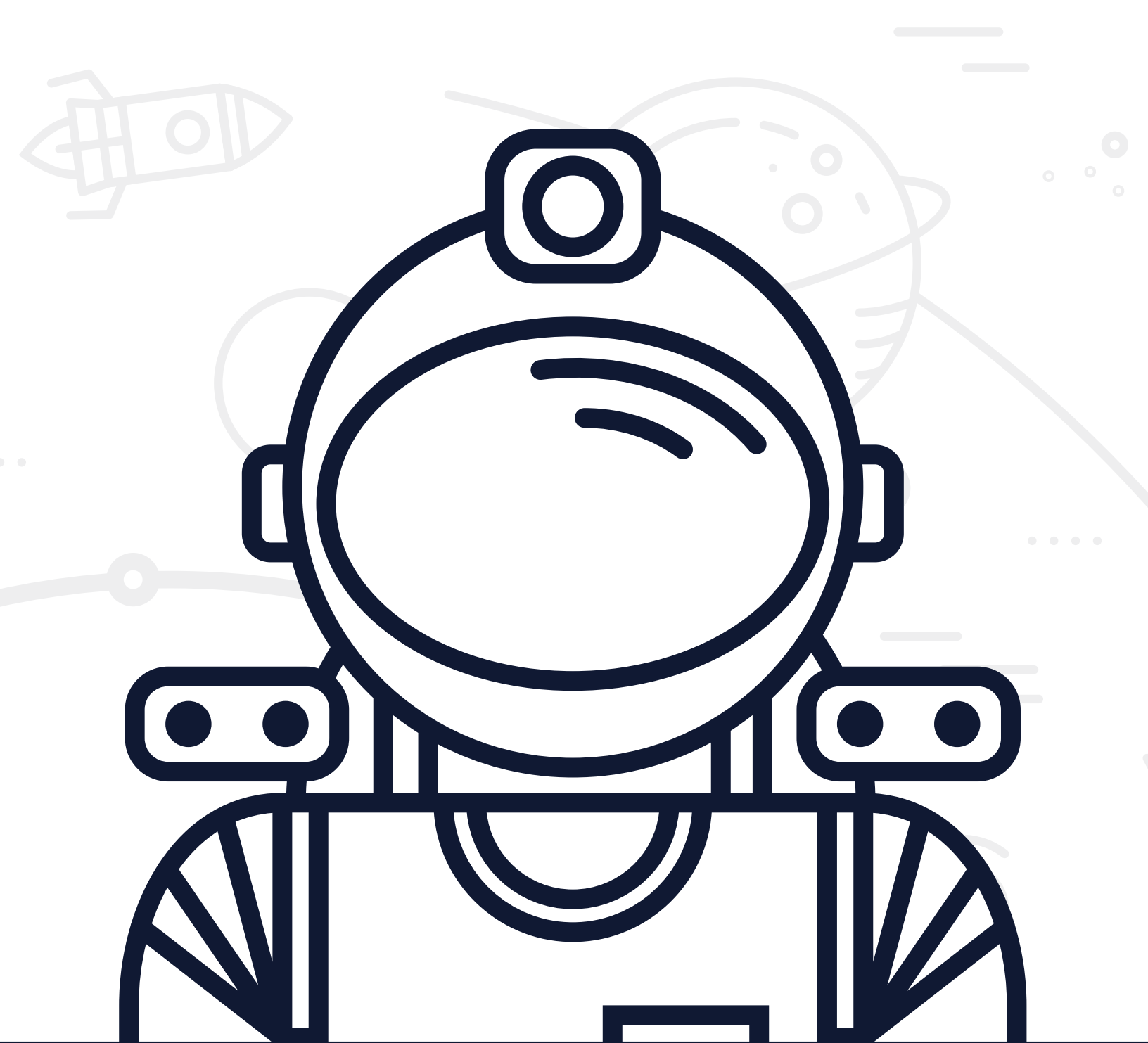

# L A U N C H

A GUIDE FOR ARIZONA HIGH SCHOOL SENIORS



This guide belongs to: \_\_\_\_\_

My postsecondary destination:

- |  |   |  |
|--|---|--|
| <input type="checkbox"/> University          | <input type="checkbox"/> Community College-Transfer | <input type="checkbox"/> Community College |
| <input type="checkbox"/> Technical Institute | <input type="checkbox"/> Military                   | <input type="checkbox"/> Workforce         |

## Important Contacts

School Counselor: \_\_\_\_\_ phone or email: \_\_\_\_\_

Other: \_\_\_\_\_ phone or email: \_\_\_\_\_

# Congratulations – You’re a senior!

You’ve been dreaming for years about what you’ll do after you graduate, and this is the year you’ll take many **critical** steps to launch your dreams into reality.

**crit-i-cal** /'kridək(ə)l/  
adjective

*having a decisive or crucial importance in the success, failure, or existence of something.*

*“submitting a college application before the deadline is a critical factor in getting accepted to college”*

*Synonyms: crucial, vital, essential, important, paramount, key, pivotal.*

*“the completion of the FAFSA is critical for obtaining financial aid.”*

*Antonyms: unimportant*

Section 1 of this Guide outlines the actions you need to take this year, depending on what you want to do after high school, and Sections 2 through 8 provide important information and resources to help you take those actions.

Beginning with Section 1, look for the checklist that applies to you – based on whether you plan to:

- Attend a four-year college or **university** to earn a bachelor’s degree
- Enroll in a **community college** first, then **transfer** to a university after 2 or 3 years to earn a bachelor’s degree
- Obtain an associate’s degree or certificate at a **community college**
- Obtain a certificate or license in a skilled trade at a **technical institute**
- Enlist in the **military**, or
- Immediately enter the **workforce**

The checklist for each plan provides timelines for completing each action, but you’ll need to pay attention to specific deadlines and due dates, since they vary.

Beyond Section 1, you’ll find resources and information on everything from financing your college education to writing a resume. You’ll also find helpful tools for tracking the status of your college, scholarship, and job applications, and pages for recording important information you’ll need to access regularly throughout the year.

It’s a good idea to keep this guide with you so you have easy access to all this stuff anytime you need it!



We know you’re excited to graduate. But it’s important, this year, that you stay focused, both on your class work, as well as the important actions outlined in this Guide.

And don’t forget your School Counselor is available throughout the year to help you through every step.

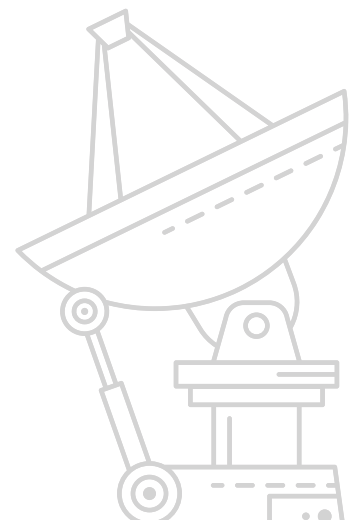

# Senior Year Guide

## Table of Contents

7

### SECTION 1

#### **Preflight Checklists: Actions and Timelines**

- 7 Staying on Track
- 8 Four-Year University (bachelor's degree)
- 9 Community College (transfer, associate's, or certificate)
- 10 Technical School (certificate)
- 11 Military Enlistment
- 12 Workforce

15

### SECTION 2

#### **Flight Preparations: The College Application Process**

Taking Your Education to the Next Level

- 15 Collecting Personal Information
- 18 What is the Best Fit for Me?
- 20 Tracking College Applications
- 22 Taking or Re-taking College Entrance Exams
- 24 You're Accepted...Now What?
- 25 Transferring from a Community College to a University

29

### SECTION 3

#### **Securing Funding: Financial Aid**

Paying for College

- 29 What is Financial Aid?
- 30 FAFSA (Free Application for Federal Student Aid) Facts
- 31 Pre-FAFSA Information
- 32 FSA (Federal Student Aid) ID Form
- 33 What Is My Dependency Status?
- 34 SAR (Student Aid Report)
- 35 Sample SAR
- 36 Financial Aid Award Letters

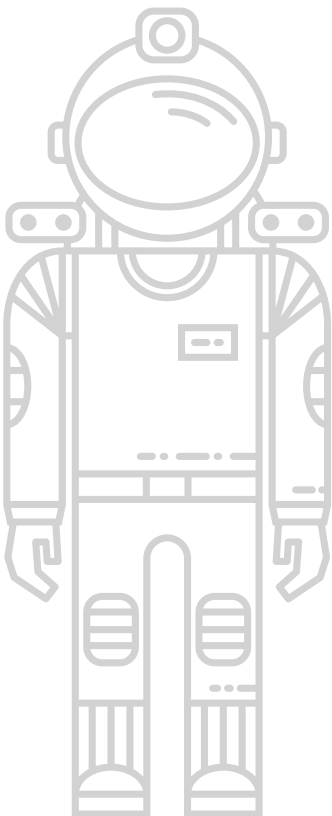

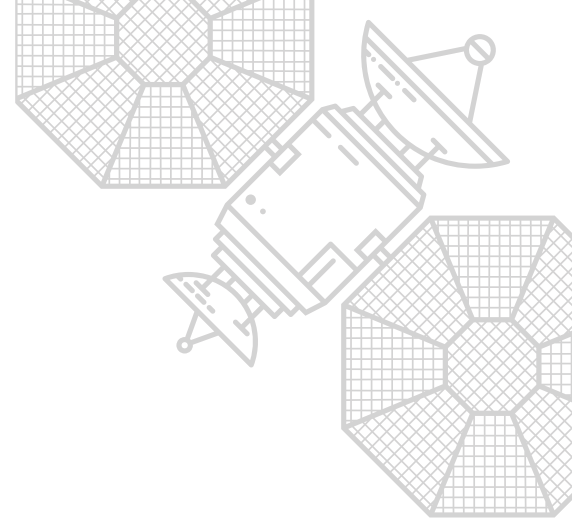

## 39

### SECTION 4

#### Help with Lift-Off: Scholarships

Why Scholarships?

- 39 The What, Where & How of Scholarships
- 40 Writing a Personal Statement
- 41 Writing a Stand-Out Essay
- 42 Letters of Recommendation
- 43 Recommendation Request Form
- 44 Scholarship Application Tracking

## 47

### SECTION 5

#### One Small Step, One Giant Leap: Pursuing a Future in the Military

Joining the Armed Forces

- 47 General Information about Enlisting and the ROTC Alternative

## 51

### SECTION 6

#### Entering Orbit: Going into the Workforce

- 51 When Entering the Workforce is Your First Step
- 52 Resume and Job Application Information
- 54 Creating a Resume
- 56 Creating a Cover Letter
- 58 Tracking Job Applications

## 61

### SECTION 7

#### Reaching for the Stars: Information for Undocumented Students

- 61 A Pathway to College for ALL Students
- 62 Four Things You Need to Know about College
- 63 Questions and Answers about Paying for College
- 64 FAFSA Information

## 67

### SECTION 8

#### Final Systems Check

- 67 Final Checklist
- 68 Glossary
- 72 Usernames and Passwords



# Section 1

## Preflight Checklists: Actions and Timelines

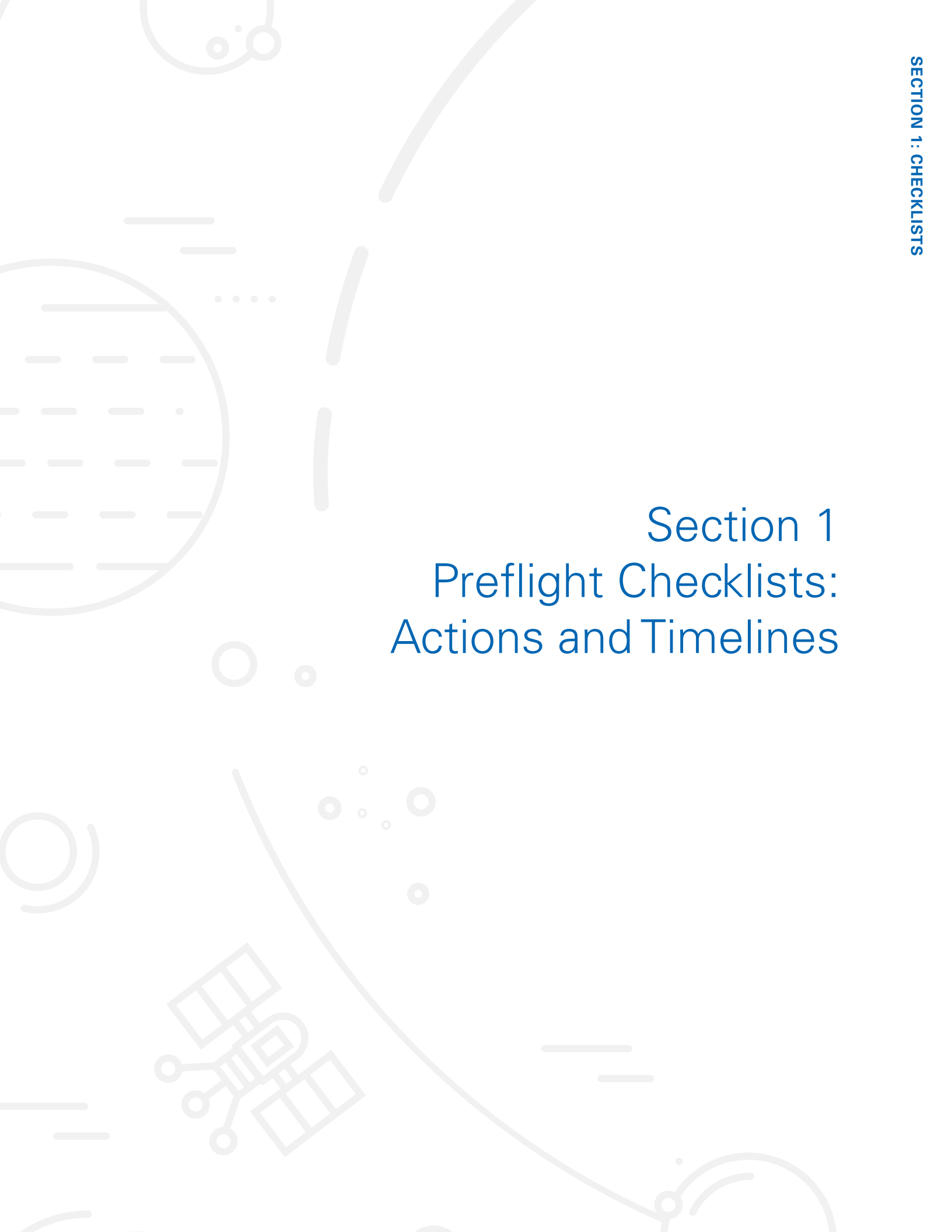





SECTION 1

# Staying on Track

Wherever you plan to go after high school graduation – whether you’re headed to college, the workforce or the military – the checklists in this section will help you stay organized and on track to reach your goal. Each checklist outlines specific action steps that act as a guide to your postsecondary plan. Simply find the checklist that applies to you, then use the pages throughout this guide, coded with the matching symbol, to find the information and resources you need to successfully complete each step on your checklist.

Review the entire checklist for your postsecondary plan before you begin, because it is helpful to see the complete picture of everything that needs to happen before you begin to tackle each step. If you’re unsure about anything on your checklist, explore the rest of this guide, which includes additional details on how to complete each step, such as applying for and paying for college. Pages in this guide are marked with a symbol to make it easy for you to find the information and resources applicable to you and your specific plan (see symbol key). If you’re still unsure about something, your School Counselor can help.

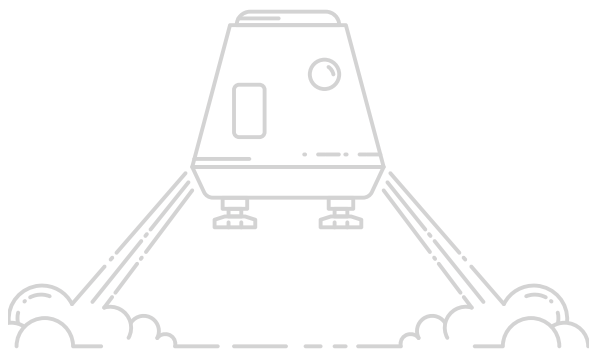
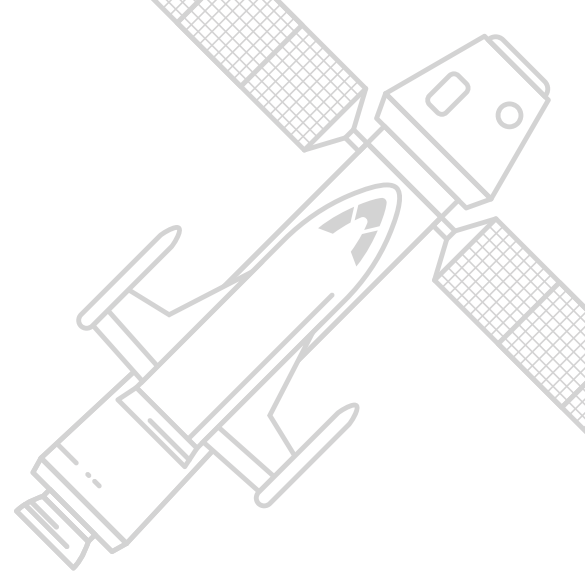

If you plan to...	Look for Symbol
Attend <b>university</b> next year	U
Enroll in a <b>community college</b> first and then <b>transfer</b> to a university	Tr
Enroll in a <b>community college</b> to earn an <b>associate’s degree</b> or <b>certificate</b>	Cc
Attend a <b>technical institute</b> next year	Ti
Enlist in the <b>military</b>	M
Enter the <b>workforce</b> after graduation	W

# Four-Year University

**If your plan is to attend a four-year college or university and earn a bachelor’s degree (including ROTC programs and military academies) this checklist is for you!**

My top three schools of choice (see Section 2 for resources to help select schools):

1. \_\_\_\_\_
2. \_\_\_\_\_
3. \_\_\_\_\_

List the majors you are considering here: (see Section 6 for resources to help decide a career pathway):

1. \_\_\_\_\_
2. \_\_\_\_\_
3. \_\_\_\_\_

	Action Steps	Recommended Timeline	My Date	Notes
Do these for every school where you will apply	Obtain college application fee waiver(s)	Aug - Sept		
	Complete college app(s), inc. fee or using fee waiver	Aug - Sept		
	Request/mail transcripts (& CLEP test scores if applicable)	Within 1 week of completing college app		
	Register to take or re-take ACT/SAT	Prep- July - Oct Retake- Nov - Dec		
	Ensure ACT/SAT scores are reported to schools	Aug - Dec		
	Explore ROTC or officer programs	Aug - Dec		
	Obtain FSA ID (student & parent)	July - Sept		
	Complete FAFSA	Oct - Dec		
	Review SAR	Oct - Dec		
	Complete scholarship apps (personal essay)	Aug - May		
	Review admission letters and financial awards	Oct - Apr		
Do these for the college where you will go	Accept admission at school of choice	As early as you know. By May		
	Pay or defer enrollment deposit to selected school	After accepting admission. Spring		
	Register for orientation	After accepting admission. Spring		
	Apply for housing	After accepting admission. Spring		
	Learn about TRiO/bridge programs & apply	After accepting admission. Spring		
	Inform Counselor of Decisions & Awards	Spring		
	Other:			



# Community College (transfer, associate's, or certificate)

**If you want to earn a bachelors degree by starting at a community college and then transferring to a 4-year university - or if you want to attend a community college to earn an associate's degree or a certificate - then this checklist is for you!**

My top schools of choice are (see Section 2 for resources to help select schools):

1. \_\_\_\_\_
2. \_\_\_\_\_
3. \_\_\_\_\_

The degree I'm pursuing (circle one):

- Transfer (2 or 3 years at the community college, plus 2 or 1 at a university)
- Associate's degree (2 years)
- Certificate (culinary arts or fire science, for example)

If you know what career you want to pursue, but you're not sure how much education you need, visit [bls.gov/oo](http://bls.gov/oo) to learn more about educational requirements, pay, and the outlook for the profession.

	Action Steps	Recommended Timeline	My Date	Notes
Do these for every school where you will apply	Obtain college application fee waiver(s)	Aug - Sept		
	Complete college app(s), inc. fee or using fee waiver	Aug - Sept		
	Request/mail transcripts (& CLEP test scores)	Within 1 week of completing college app		
	Prep for and take/retake placement tests (e.g., Accuplacer)	Prep - July - Oct Take/retake- Nov - Dec		
	Obtain FSA ID (student & parent)	July - Sept		
	Complete FAFSA	Oct - Dec		
	Review SAR	Oct - Dec		
	Complete scholarship apps (personal essay)	Aug - May		
	Review admission letters and financial awards	Oct - Apr		
Do these for the college where you will go	Accept admission at school of choice	As early as you know. By May		
	Talk with a community college academic advisor	Mar - May		
	Apply for housing	After accepting admission. Spring		
	Explore program of study (including transfer programs)	Spring		
	Learn about TRiO/bridge programs & apply	After accepting admission. Spring		
	Inform Counselor of Decisions & Awards	Spring		
	Other:			



SECTION 1

# Technical Institute/School

**If you want to attend a technical institute/school and obtain a certificate or license in a skilled trade, this checklist is for you!** At tech schools, you can train to become a certified professional in a variety of fields, such as a motorcycle mechanic, a nurse or a computer technician.

My top schools of choice are (see section 2 for resources to help select schools):

I'm interested in pursuing a career in (see section 6 for resources to help decide a career pathway):

1. \_\_\_\_\_
2. \_\_\_\_\_
3. \_\_\_\_\_

If you know what career you want to pursue, but you're not sure how much education you need, visit [bls.gov/oo](http://bls.gov/oo) to learn more about educational requirements, pay, and the outlook for the profession.

Action Steps	Recommended Timeline	My Date	Notes
Check to see if community college has program of study needed; compare cost	Aug - Dec		
Obtain app fee waiver(s)	Aug - Dec		
Complete tech school application(s)	Feb		
Send add'l requirements (transcript, test scores, portfolio, etc)	Aug - Dec		
Obtain FSA ID (student & parent)	Jul - Sept		
Complete FAFSA	Oct - Dec		
Review SAR	Oct - Dec		
Complete scholarship apps (personal essay)	Aug - May		
Review admission letters and financial awards	Oct - Apr		
Accept admission at school of choice	As early as you know. By May		
Explore career outlook	Mar - May		
Apply for housing	After accepting admission. Spring		
Inform Counselor of Decisions & Awards	After accepting admission. Spring		
Other:			

# Military Enlistment

**If you plan to enlist in the military immediately after high school, then this checklist is for you!** Section 5 has more details on entering military service.

I plan to join the:

- Army
  Navy
  Air Force
  Marines
  Coast Guard

If you are interested in ROTC, use the university checklist on page 8.

Action Steps	Recommended Timeline	My Date	Notes
Schedule appointment with Military Recruiter	Fall		
Take or re-take ASVAB	Fall		
Discuss Delayed Entry Program with recruiter	Fall		
Complete Physical Examination with Military Entrance Processing Station (MEPS)	As directed by recruiter (Fall/Winter)		
Review ASVAB scores with School Counselor	Spring		
Research potential careers for service	Spring		
Meet with Enlistment Counselor to determine career prospects	As directed by recruiter		
Take the Oath of Enlistment	As directed by recruiter		
Prepare for Boot Camp	Spring		
Other:			



SECTION 1

# Workforce

**If you plan to enter the workforce immediately after high school graduation, then this checklist is for you!**

My career interest areas or job prospects include (see Section 6 for resources to help determine a career pathway):

1. \_\_\_\_\_
2. \_\_\_\_\_
3. \_\_\_\_\_

Visit [bls.gov/ooh](http://bls.gov/ooh) to learn more about educational requirements, pay, and the outlook for the fields you're considering pursuing after graduation.

Action Steps	Recommended Timeline	My Date	Notes
Research training required for field of interest	Fall / Winter		
Research community college options/programs	Fall / Winter		
Ask people to serve as references	Spring		
Create / update resume (See Section 6)	Winter/Spring		
Research job openings	Spring		
Prepare for job applications by completing form in Section 6	Winter/Spring		
Apply for jobs	Spring		
Request letters of recommendation	as required for application		
Inform Counselor of job placement	As soon as you're hired; May at latest		
Other:			
Other:			



# Section 2

## Flight Preparations: The College Application Process

# Taking Your Education to the Next Level

If you're planning to continue your education after high school—whether you're headed to a university, community college, or tech school – this section will help you get there. In the following pages you'll find guidance related to choosing a school, submitting college applications, preparing for and taking college entrance exams, and smoothly transferring from a community college to a university.

For details on paying for college, see sections 3 and 4.



# Collecting Personal Information

Take a few minutes to fill out this form. Then with your high school **transcript** in hand, you'll have everything you need to complete most college applications. You might need to work with your parent or family members to get all the details.

When it comes time to apply, many universities charge a fee—\$50 or \$100 application fees are common. However, it is likely that you can get this fee waived. Contact your School Counselor to find out how.

Leave areas blank if they don't apply to you.

Contact Information	
Full Name (first, middle, last)	
Street Address	
PO Box	
City, State, Zip Code	
Home Phone Number	
Mobile Phone Number	
E-Mail Address (not your high school email address)	
Social Security Number	
Driver's License Number and Date Issued	
Date of birth	
School Information	
Name of Current High School	
Street Address, City, State, Zip Code	
Telephone Number	
Expected Graduation Date	
Name of Previous High School Attended	
Street Address, City, State, Zip Code	
Telephone Number	
Dates Attended	
Colleges Attended/College Credits Earned	
(List any college from which you expect to receive credit - including dual enrollment or concurrent enrollment).	
College Name	
Street Address, City, State, Zip Code	
Dates Attended	
Course Name/Number of Credits	
Course Name/Number of Credits	
Potential College Major	





SECTION 2

# Collecting Personal Information

Testing (ACT, SAT, AP, CLEP)					
SAT Date (month/year)		Comp Score			
ACT Date (month/year)		Comp Score			
AP Subject:	Score	AP Subject	Score		
CLEP Subject	Score	CLEP Subject	Score		

Athletics, Clubs and Organizations				
List name of club/sports team	List your role/position each year			
	Freshman	Sophomore	Junior	Senior

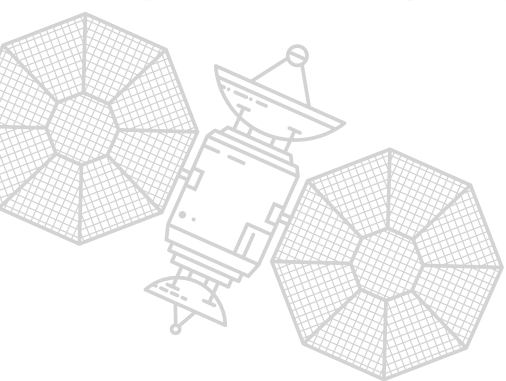

Honors & Awards		
Name and Date of Award	Reason for Award/Honor	Sponsor

Community Service			
Name of the organization/ contact	Description of volunteer service	Number of hours of service	Date(s) of service

**Family Information and Other Personal Information**

Student's status:

- US Citizen    
  Permanent US Resident    
  Refugee    
  Asylee    
  DACA

State of residence: \_\_\_\_\_

Have either of your parents earned a bachelor's degree or higher?      Yes      No

Are your parents affiliated with the US military?      Yes      No

**Emergency Contact**

Name/relationship: \_\_\_\_\_

Phone Number: \_\_\_\_\_

Address: \_\_\_\_\_

\_\_\_\_\_

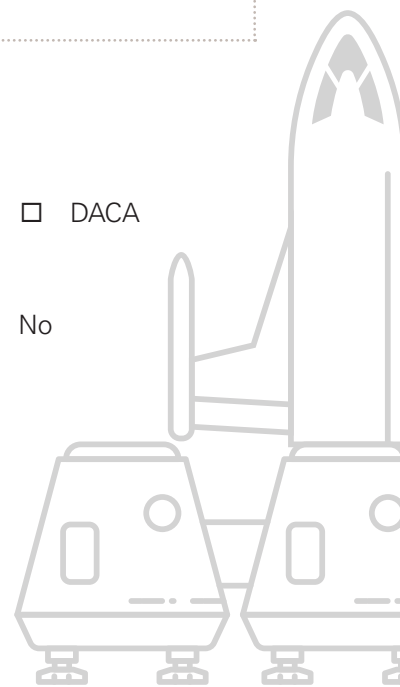



SECTION 2

# What is the Best Fit for Me?

Deciding which college to attend can be a challenge – there are so many factors to consider!

Decide what is most important to you in a college experience, along with your long-term goals and how college will play a part in achieving those goals. By visiting college websites, talking with current and former students and reading online reviews, try to learn as much as possible about your potential school.

Below are some things you might want to consider as you research.

How would you rank order what is most important to you?

<p><b>Type of School</b></p> <ul style="list-style-type: none"> <li>• 2 year or 4 year</li> <li>• Public or private</li> <li>• University/research institution or liberal arts college</li> <li>• All male, all female, or coed</li> <li>• Religious or secular</li> </ul>	<p><b>Student Life</b></p> <ul style="list-style-type: none"> <li>• On and off campus activities</li> <li>• Athletics</li> <li>• Greek life</li> <li>• Student organizations</li> <li>• Safety</li> <li>• Student body diversity</li> </ul>	<p><b>Location</b></p> <ul style="list-style-type: none"> <li>• Urban or rural</li> <li>• Size of nearest city</li> <li>• Distance from home</li> <li>• Geographic setting and weather</li> </ul>
<p><b>Affordability</b></p> <ul style="list-style-type: none"> <li>• Cost of Attendance (tuition, fees, transportation, housing)</li> <li>• Scholarships</li> <li>• Campus employment opportunities</li> </ul>	<p><b>Admission Requirements</b></p> <ul style="list-style-type: none"> <li>• Minimum GPA</li> <li>• Average test scores</li> <li>• Required high school courses</li> <li>• Likelihood of being accepted</li> </ul>	<p><b>Housing</b></p> <ul style="list-style-type: none"> <li>• Residence halls</li> <li>• On/off campus housing</li> <li>• Meal plan</li> <li>• Parking for residents and for commuters</li> </ul>
<p><b>Academics</b></p> <ul style="list-style-type: none"> <li>• Programs and majors offered</li> <li>• Student-faculty ratio</li> <li>• Accreditation</li> </ul>	<p><b>Size</b></p> <ul style="list-style-type: none"> <li>• Physical enrollment</li> <li>• Average class size</li> <li>• Physical size of campus</li> </ul>	<p><b>Other criteria important to you</b></p> <ul style="list-style-type: none"> <li>•</li> <li>•</li> </ul>

How do the schools you're interested in measure up? Here's a chart to help you compare the colleges you are interested in, with the criteria that is most important to you.

	College:	College:	College:	College:
Criteria				
Type of School				
Student Life				
Location				
Affordability				
Admission Requirements				
Housing				
Academics				
Size				
Other				
Other				
Other				



SECTION 2

# Tracking College Applications

As you begin the college application process, it's a good idea to include at least one of each of the following types of **choices**:

- **Safe choice** –Your academic credentials fall above the school’s range for the average freshman. You can be reasonably certain that you will be admitted to your safe choice school.
- **Realistic choice** –Your academic credentials fall within (or even exceed) the school’s range for the average freshman. There are no guarantees, but it’s not unreasonable to be accepted to several of your realistic choice schools.

Use this table to keep track of your progress on your college applications:

Tracking College Applications				
	Application Deadline (note priority deadline, if applicable)	Date you applied	Date you sent application payment/ waiver	Date you sent your official HS transcript
College #1				
College #2				
College #3				
College #4				
College #5				

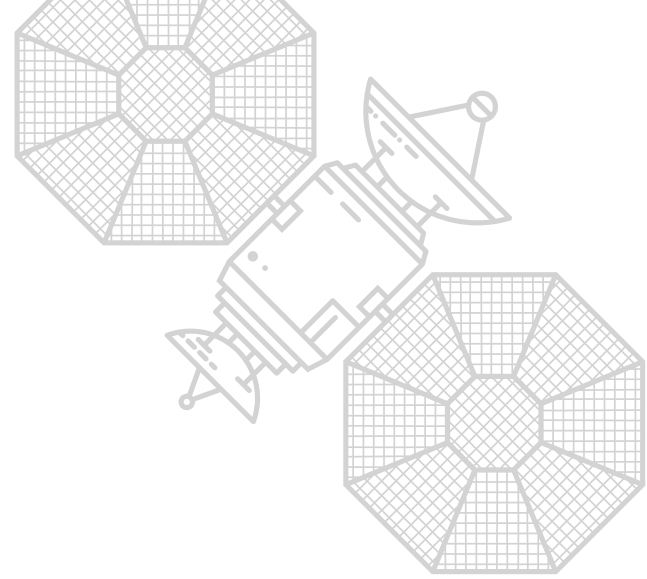

- Reach choice** – Your academic credentials fall below the school’s range for the average freshman. Reach schools are important to apply to – if there is a specific, selective college you really want to go to and you have even a remote shot at getting accepted, go for it.

Date you sent college transcript, if applicable	Date you sent test scores: CLEP, AP, ACT, SAT	Received response - Accepted Yes or No?	Financial Award Letter Received and Reviewed Yes or No?



## SECTION 2

# Taking or Re-taking College Entrance Exams

The ACT and SAT are college admissions tests. Many colleges and programs use ACT or SAT scores in their admission decisions, although some do not, and some specifically require one test or the other. So check the requirements for the colleges to which you're applying. Arizona's three state universities don't require a certain score on either test for admission generally, but some specific majors do use these scores in their admission decisions. Universities also often use your ACT or SAT score in specific subject areas to determine freshman year course placement, particularly for math.

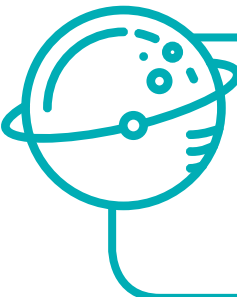

You will need an SAT or ACT score to be considered for merit scholarships - higher scores can earn you larger scholarship awards!

**I already took the ACT as a junior. Should I re-take it this year?** Once you've received your ACT score report, take a moment to congratulate yourself! Completing a three-hour exam is an accomplishment in itself. Next, realize that sometimes students need to take the exam two or three times to maximize their score. This is completely normal; in fact, most students take the test more than once. Here's how to decide whether you should re-take it:

**1. What are the scores necessary for your target schools or target scholarships?** Take a moment to research the schools you want to go to. Many schools list the average or mid-range SAT and ACT scores for their admitted students directly on their website (check the Admissions section). Aim to be at or above their posted average score, but keep in mind that extracurriculars and GPA also factor into the admission decision. Use

the "scholarship estimator" tools on college websites to figure out whether a higher score could earn you a bigger scholarship and if so, how likely is it you could improve your score by the needed amount.

- 2. How many times have you already taken the test?** Although it is true that retaking the test can raise your score, after the third time taking the exam, subsequent attempts at the test are unlikely to raise your score unless you've done something drastically different to prepare. Just taking the test over and over is pretty pointless if you don't change anything in between attempts.
- 3. Are my score expectations realistic?** Going up by 3 or 4 points on the ACT is a realistic goal with effort, especially from your first to second time taking the test. It is also important to realize that the higher your starting score is, the harder it is to get your score up with future retakes. For example, if you've already scored a 34 on the ACT and have taken the test twice already, it probably isn't necessary to take the test for a third time. Also, recognize that score improvements don't come without effort.
- 4. How do I move forward?** If you've considered these questions and come to the conclusion that you don't want or need to retake the ACT, congratulations! Focus on completing your applications and essays, and on making a strong finish in your high school career. If you do want to retake the ACT then pick a test date that fits your schedule and deadlines and start using the prep tools available: [kahnacademy.org/sat](http://kahnacademy.org/sat) for the SAT; on-line ACT prep available free for students with ACT fee waivers, or ask your School Counselor for test prep resources at your school.

<sup>1</sup> Sources: [testive.com](http://testive.com) and [act.org/content/dam/act/unsecured/documents/ACT-Score-Report-eBook.pdf](http://act.org/content/dam/act/unsecured/documents/ACT-Score-Report-eBook.pdf)



## SAT vs. ACT



SAT	ACT
<b>Scores</b>	
The SAT is scored on a scale of 400-1600	The ACT is scored on a scale of 1-36
<b>Questions</b>	
SAT questions require more time to understand and answer	ACT questions tend to be more straightforward
<b>Reading</b>	
The SAT has 5 reading passages	The ACT has 4 reading passages
<b>Science</b>	
There is no Science Test on the SAT	The ACT has a science section that tests your critical thinking skills
<b>Math</b>	
Both tests now have the SAME advanced math concepts: Arithmetic, Algebra I & II, Geometry and Trigonometry	
<b>Tools</b>	
Some SAT math questions don't allow you to use a calculator	You may use a calculator for ALL the math questions on the ACT
<b>Essay</b>	
Both essays are OPTIONAL	
The SAT essay section is more comprehension focused. You have 50 minutes to complete it	The ACT wants to see how well you can evaluate and analyze complex issues. You have 40 minutes to complete it

*Adapted from The Princeton Review*

Need to re-take the SAT or ACT? Talk to your School Counselor to find out about test dates, test fee waivers and test prep options. You must register 5 weeks before the test date!

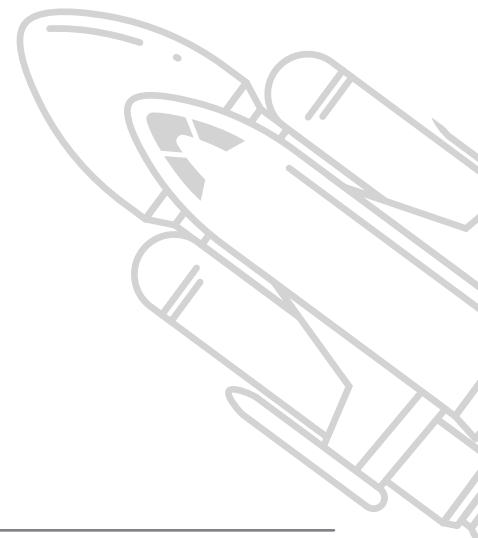



SECTION 2

# You're Accepted...Now What?

Once you've received your acceptance letters and decided on a school, there are still a few actions you'll need to take to secure your spot. Plus, you'll want to keep track of some key information.

Use the tools on this page to help you keep everything organized and on-time.



Be sure to check your college email account regularly.

If you have questions about processes or next steps, check in with your college representative, financial aid counselor or admissions counselor.

The college I am attending next year is: \_\_\_\_\_

My admissions counselor's name: \_\_\_\_\_

email: \_\_\_\_\_ Phone: \_\_\_\_\_

My financial aid counselor's name: \_\_\_\_\_

email: \_\_\_\_\_ Phone: \_\_\_\_\_

My college username: \_\_\_\_\_ email: \_\_\_\_\_

My college ID #: \_\_\_\_\_

Date I accepted admissions offer	Date I paid/deferred enrollment deposit	Date I applied for housing	Orientation date I selected	Date I sent my final transcript	Date I accepted/declined financial awards	Date I sent my immunization records

### Summer Bridge Programs

Name: \_\_\_\_\_

Application deadline: \_\_\_\_\_ Date applied: \_\_\_\_\_

Name: \_\_\_\_\_

Application deadline: \_\_\_\_\_ Date applied: \_\_\_\_\_

Notes: \_\_\_\_\_

\_\_\_\_\_  
\_\_\_\_\_

First-year programs or other organizations I am interested in joining (include TRiO programs if available):

\_\_\_\_\_  
\_\_\_\_\_

# Transferring from a Community College to a University

If your plan after high school is to attend a community college first and then transfer to a 4-year university, it will be important to learn about specific transfer programs like 2NAU, UA Bridge and ASU TAG. These programs, and other resources, such as AZtransfer.com, will help you ensure that none of your study time is wasted and that as many of your community college courses as possible, will transfer to the university of your choice and apply towards your degree.

Meet with your community college advisor early and often – academic advisors are your key to a smooth transfer. Share your goals with your advisor so that he/she can help you understand the Arizona General Education Curriculum (AGEC) requirements. Successfully completing these requirements means your courses will transfer from the community college to the Arizona university of your choice.

Better yet, if you complete the AGEC with a 2.5 GPA or better, you are guaranteed admission to ASU, NAU and UA. Your advisor will help you learn about specific transfer programs like MAPPs, TAGs, 2NAU, and UA Bridge, and help you monitor your progress to ensure you are on track to complete your plan.

## aztransfer.com

aztransfer.com is a free website that shows you how to earn credit at your community college that will apply towards your bachelor's degree at ASU, NAU, and UA. Search the Course Equivalency Guide to learn how courses transfer, use the Exam Equivalency Guide to see how AP and IB exam scores translate to college credit, and much more.



## Arizona university transfer programs:

- Arizona State University: Seamlessly transfer to ASU with **MAPPs** and **TAGs**. Learn more about these transfer programs so you can become a Sun Devil!
- Northern Arizona University: You can be a Lumberjack anywhere! The **2NAU** program helps community college students transfer to Flagstaff or one of many local campuses.
- University of Arizona: The Arizona Wildcats welcome transfer students! Learn about the **UA Bridge** and other transfer options.

Adapted from: aztransfer.com

## Building your Transfer Degree

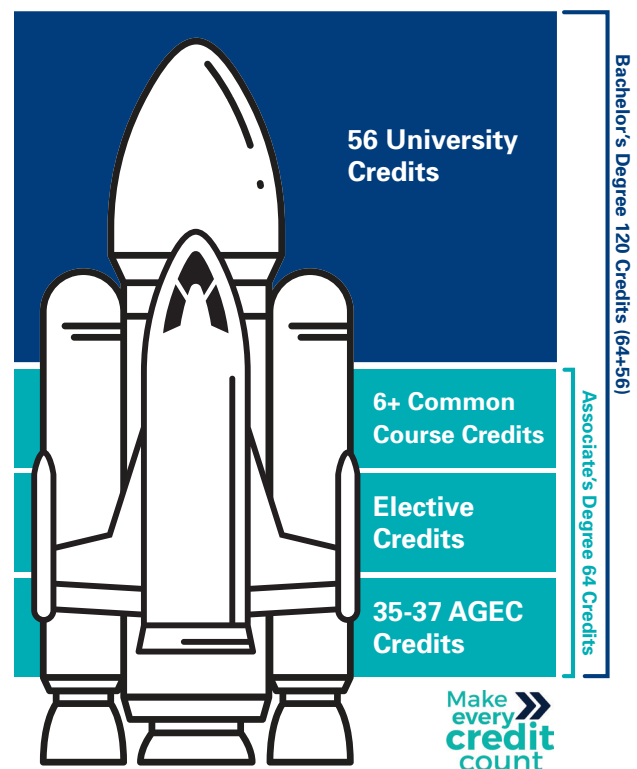



# Section 3 Securing Funding: Financial Aid

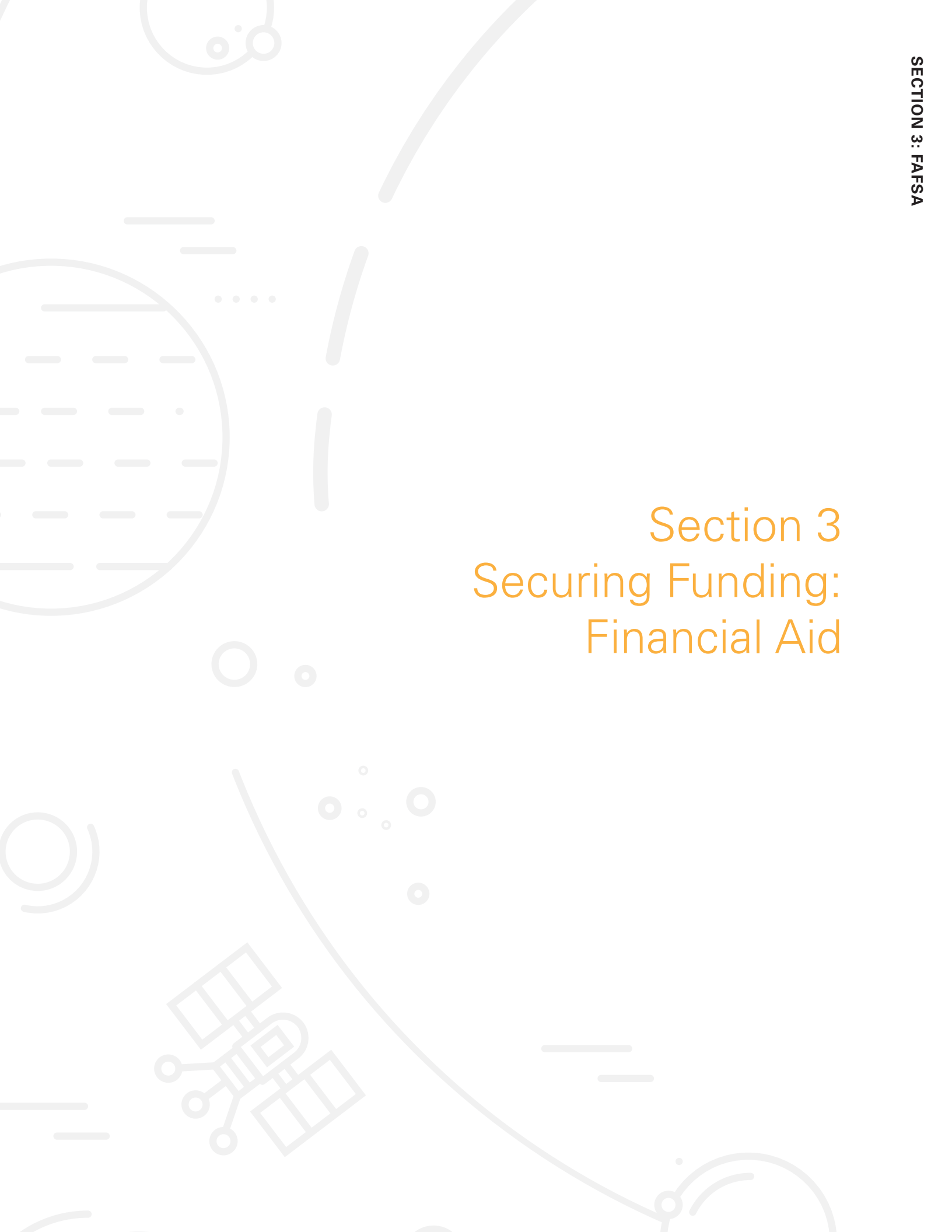

## Paying for College

If you're concerned about how you're going to pay for your college or university experience, consider this:

- College might not cost as much as you think. In fact, most families overestimate the price tag.
- There is help available. Financial aid can make paying for school realistic.
- Your education is a long-term investment. On average, college graduates earn twice as much as those with high school diplomas.

In this section of the guide, you will find information about types of financial aid, how to apply for aid, and how to interpret the financial aid offers you receive.

# What is Financial Aid?

Financial aid is money to help you pay for college. It may be in the form of grants, scholarships, loans, work-study programs, or a combination. The aid comes from the federal and state governments, colleges and universities, banks, and private organizations.

Applying to receive financial aid is a separate process from applying for admission to a college. You have to do both. For all government aid, and much private and institutional aid, you apply using the Free Application for Federal Student Aid, or FAFSA (see coming pages in this section for more details).



## Four Primary Sources of Financial Aid

### 1. Pell grants

Money provided by the federal government to college students who demonstrate financial need. Pell grants do not need to be paid back. For 2017, the maximum grant, which is available to students in the most need, is \$5,920\*. To earn a Pell grant, you must be a U.S. citizen or eligible noncitizen and will need to complete the FAFSA (Free Application for Federal Student Aid).

### 2. Work-Study

This federally sponsored program provides students with part-time employment (often on campus) during college. Eligibility is based on financial need; students must complete the FAFSA to be considered.

### 3. Scholarships

Money for college that does not have to be repaid. Scholarships are awarded to all types of students. Some scholarships are for students with an exceptional academic record in high school and others are for students who possess certain characteristics important to the provider (such as hobbies, athletic ability, membership in a particular group, etc.). Most scholarships require an application, and dollar amounts vary. Applying for private aid through scholarships is covered in section 4.

### 4. Loans

This is borrowed money that must be repaid with interest. It's similar to a car loan. (see the glossary for more information)

*\*This amount may change every year*

Two out of every three college students receive some type of financial assistance.

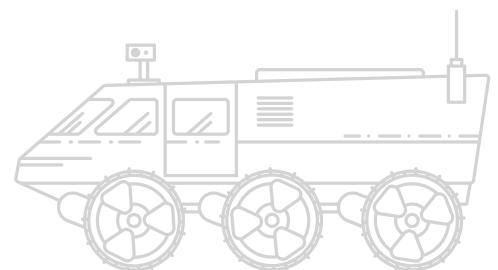



## SECTION 3

# FAFSA (Free Application for Federal Student Aid) Facts

Filing the FAFSA is free! We've made it easy for you to gather the information you will need to complete the FAFSA. The FAFSA is an important part of your journey and it might even mean free money to cover your college costs.

The next few pages provide helpful forms and sample documents to get you through the three major steps to complete the FAFSA:

1. **Get your FSA ID (you and your parent), see pages 31 and 32**
2. **Complete the FAFSA (with your parent), see page 31 and 33**
3. **Review your SAR, see page 34 and 35.**

We've also included information to help you understand the financial aid award offers you receive from your college(s).

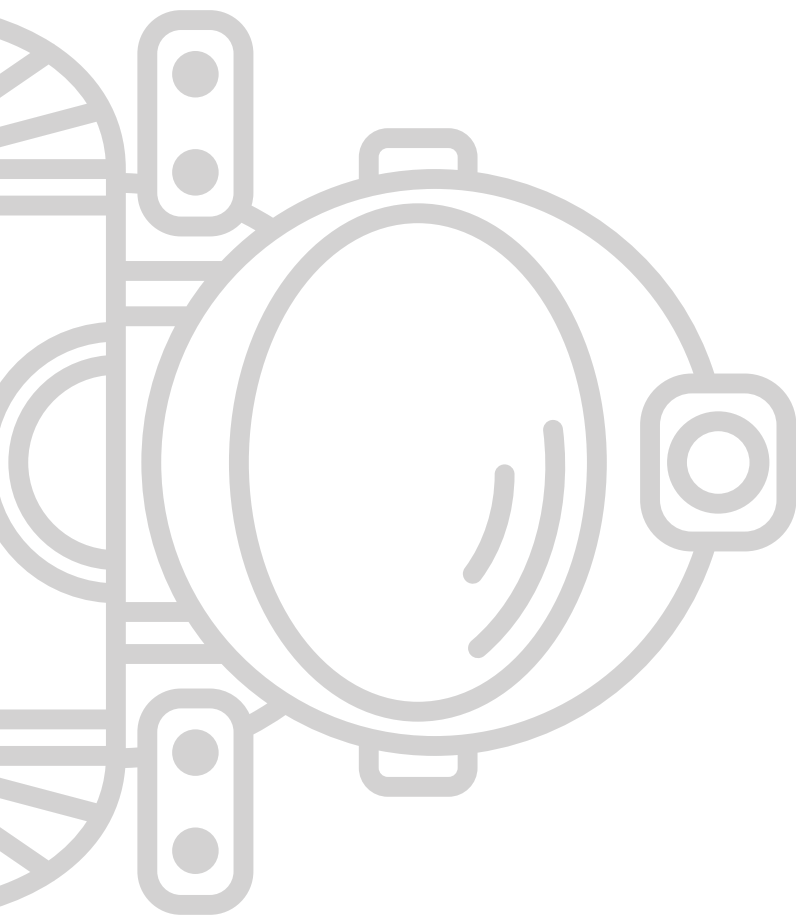

## **fafsa.gov**

At [fafsa.gov](https://fafsa.gov), you can complete, submit, and track your application. However, if you do not have Internet access, you can get a paper copy by calling 1-800-4-FED-AID (433-3243). Remember, filing the FAFSA is free. If you see a website or ad requesting a fee, steer clear!

To learn more about how to complete the FAFSA correctly, visit [www.studentaid.ed.gov/fafsa-fillingout](https://www.studentaid.ed.gov/fafsa-fillingout).



SECTION 3

# Pre-FAFSA Information



By filling in this form, you will have, in one convenient place, all the information you need to create your FSA ID online and to complete your FAFSA.

1. Student Email (not your high school email): \_\_\_\_\_ cell phone: \_\_\_\_\_  
Parent Email: \_\_\_\_\_ cell phone: \_\_\_\_\_
2. Are you an Arizona resident?     Yes     No  
Month/Year you began living in Arizona: \_\_\_\_\_
3. Are your parents Arizona residents?     Yes     No  
Month/Year your parents began living in Arizona: \_\_\_\_\_
4. Your Social Security number: \_\_\_\_\_ - \_\_\_\_\_ - \_\_\_\_\_
5. Your parents' Social Security number:  
Parent 1: \_\_\_\_\_ - \_\_\_\_\_ - \_\_\_\_\_    Parent 2: \_\_\_\_\_ - \_\_\_\_\_ - \_\_\_\_\_
6. If you are not a U. S. citizen, what is your permanent resident card A #: \_\_\_\_\_
7. What are your parents' dates of birth?    Parent 1 D.O.B. \_\_\_\_\_ Parent 2 D.O.B. \_\_\_\_\_
8. Do you have a driver's license?     Yes     No
9. Your Driver's License #: \_\_\_\_\_ Expiration Date: \_\_\_\_\_
10. What is the month and year your parents were married, divorced or separated? \_\_\_\_\_
11. What is the highest level of school your parents completed? (circle one for each parent)  
Parent 1:    Middle school/Jr .High    High School    College or beyond    Other/unknown  
Parent 2:    Middle school/Jr. High    High School    College or beyond    Other/unknown

When you file the FAFSA, in addition to the information above, these are the items to have at hand (for yourself and your parents).

- Most recent W2 forms
- Most recent Federal Income Tax Forms
- Most current statements from all accounts (checking, savings, investments, etc.)
- Child support paid or received
- Value of investment farms and businesses
- Other prior year benefits (workers comp, military, clergy, or veteran amounts)





**SECTION 3**

# FSA (Federal Student Aid) ID Form

The first step to completing your FAFSA is to create an FSA ID (a username and password). Your FSA ID gives you access to Federal Student Aid’s online systems and serves as your legal signature. Only create an FSA ID using your own personal information and for your own exclusive use.

Fill in this form as you create your FSA ID, so you have the information when you need it to log in later. To create an FSA ID, go to **fsaid.ed.gov**.

**Student Information**

Email address: \_\_\_\_\_

Username: \_\_\_\_\_ Password: \_\_\_\_\_

Date of birth: \_\_\_\_\_ Social Security number: \_\_\_\_\_ - \_\_\_\_\_ - \_\_\_\_\_

Answer to Challenge Questions (answers are case sensitive):

Challenge Question	Answer

Significant date answer (MM/DD/YYYY): \_\_\_\_\_

**Parent Information (if applicable)**

Email address: \_\_\_\_\_

Username: \_\_\_\_\_ Password: \_\_\_\_\_

Date of birth: \_\_\_\_\_ Social Security number: \_\_\_\_\_ - \_\_\_\_\_ - \_\_\_\_\_

Answer to Challenge Questions (answers are case sensitive):

Challenge Question	Answer

Significant date answer (MM/DD/YYYY): \_\_\_\_\_

**THIS INFORMATION SHOULD BE KEPT CONFIDENTIAL AND STORED IN A SECURE LOCATION!**

# What Is My Dependency Status?

The following statements will determine your dependency status for the FAFSA. **Mark any that are true.**

<input type="checkbox"/> I will be 24 or older by Dec. 31 of the school year for which I am applying for aid	<input type="checkbox"/> I am married	<input type="checkbox"/> I will be working on a master's or doctorate program (e.g., MA, MBA, MD, JD, PhD, EdD, graduate certificate)	
<input type="checkbox"/> I am serving on active duty in the U.S. Armed Forces	<input type="checkbox"/> I am a veteran of the U.S. Armed Forces	<input type="checkbox"/> I now have or will have children for whom I provide more than half of their support	
<input type="checkbox"/> Since I turned age 13, both of my parents were deceased	<input type="checkbox"/> I was in foster care since turning age 13	<input type="checkbox"/> I have dependents (other than children or my spouse) who live with me and I provide more than half of their support	
<input type="checkbox"/> I was a dependent or ward of the court since turning age 13	<input type="checkbox"/> I am homeless or at risk of being homeless	<input type="checkbox"/> I am currently or I was in legal guardianship	<input type="checkbox"/> I am currently or I was an emancipated minor

If you marked any of the statements, you are independent and will not provide parental information on the FAFSA.

If none of the statements are true, you are a dependent student and must provide parental information on the FAFSA. Dependent students are required to include parent information on the FAFSA. Use this guide to figure out which parent's information to include on the FAFSA.

## Who's My Parent?

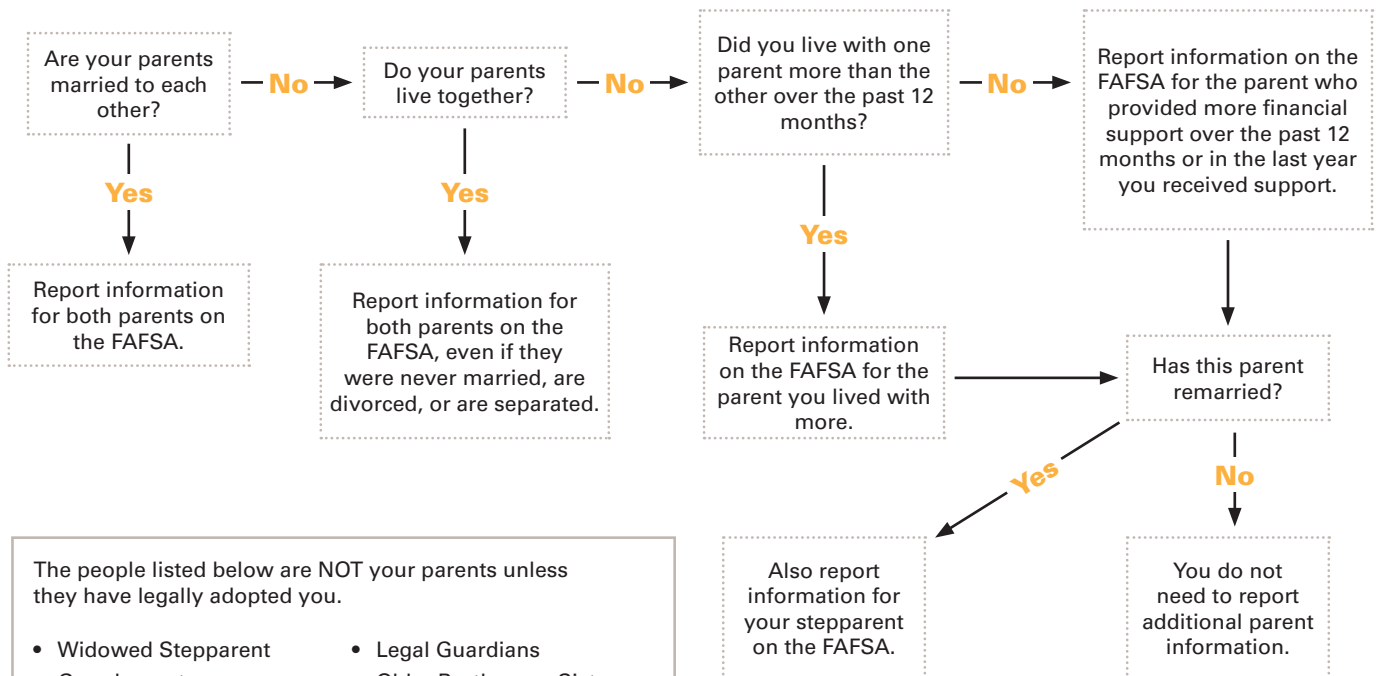

The people listed below are NOT your parents unless they have legally adopted you.

- Widowed Stepparent
- Grandparents
- Foster Parents
- Legal Guardians
- Older Brothers or Sisters
- Aunts or Uncles

Source: Arizona Commission for Postsecondary Education



## SECTION 3

# SAR (Student Aid Report):

## What is it, how do I get one and why is it important?

### What is the SAR?

The Student Aid Report (SAR) summarizes the information you submitted on your FAFSA and provides information about financial aid eligibility based on that information. A sample SAR is shown on the next page.

### How and when will I get my SAR?

After you submit your Free Application for Federal Student Aid (FAFSA), you'll get your personal SAR. (Within three days if you complete the FAFSA online; within 3 weeks if you mail the paper FAFSA).

Whether you receive your SAR online or through the mail depends on whether you provide an email address on your FAFSA. If you provide a valid email address, you'll receive an email with instructions on how to access an online copy of your SAR.

If you have an FSA ID (username and password) and your FAFSA has been processed, you can log in at [fafsa.gov](http://fafsa.gov) to view your SAR information regardless of how you filed the FAFSA.

The school(s) you list on your FAFSA will have access to your SAR data electronically within a day after it is processed.

### What information does a SAR contain (and not contain)?

The SAR won't tell you how much financial aid you'll get, but if your application is complete, an Expected Family Contribution (EFC) will display in the upper right-hand corner of your SAR and your estimated Pell grant amount will be provided. If your application is incomplete, your SAR will not include an EFC or Pell amount, but it will tell you what you need to do to resolve any issues.

The SAR also contains a four-digit Data Release Number (DRN), which appears on the first page in the upper right corner of the paper SAR and SAR Acknowledgement. On the electronic SAR, the DRN is located in the box that contains the Application Receipt date, below the EFC. You will need the DRN if you choose to allow your college or technical school to change certain information on your FAFSA.

### What am I supposed to do with my SAR?

When you get your SAR, review it carefully to make sure it's correct and complete. Take a copy of it to your School Counselor to get help reviewing it. The school(s) you listed on your FAFSA will use SAR information to determine your eligibility for federal – and possibly nonfederal – financial aid. A school may ask you to verify the accuracy of the data you provide on the FAFSA, so you need to be sure the information is correct.

If you don't have any changes to make to the information listed on your SAR, just keep it for your records.

# Sample SAR



## Federal Student Aid FAFSA

Form Approved  
OMB No. 1845-0001  
App. Exp. 12/31/2016

### Electronic Student Aid Report (SAR)

20XX-XX

Application Receipt Date:	02/21/20XX	XXX-XX-1493 BA 03
Processed Date:	03/17/20XX	EFC: 000000 *
		DRN: 3653

The SAR summarizes the information you submitted on your 20XX-XX FAFSA

Application for Federal Student Aid (FAFSA).

This is your Expected Family Contribution. The number may be all zeros, or a combination of zeros and other numbers, but if it is blank or there is a "C" after the number, you need to make corrections to your FAFSA or you won't get any aid. The details are in the body of the SAR below.

The last four digits of your social security number appear here.

#### Comments About Your Information

Learn about [federal tax benefits for education](#), including the *American Opportunity Tax Credit* (AOTC).

Based on the information we have on record for you, your EFC is 000000. You may be eligible to receive a Federal Pell Grant and other federal student aid. Your school will use your EFC to determine your financial aid eligibility for federal grants, loans, and work-study, and possible funding from your state or school.

Being selected for verification is quite common. The asterisk after the EFC above indicates this too.

Your FAFSA has been selected for a review process called verification. Your school has the authority to request copies of certain financial documents from you and your parent(s).

There is a limit to the total amount of Federal Pell Grants that a student may receive, which is the equivalent of 6 school years. Once a total amount of Pell Grant eligibility has been received, a student can no longer receive Pell Grant aid.

WHAT YOU MUST DO NOW (Use the checklist below to make sure that all of your issues are resolved.)

The date of birth you reported for your first parent on your FAFSA matches the Social Security Administration's (SSA) records, but the date of birth you reported for your second parent does not match the SSA's records. Your second parent should review the date of birth in Item 67 and either confirm the date you have reported or make the necessary correction by clicking 'Make FAFSA Corrections' on the 'My FAFSA' page.

If you need to make corrections to your information, click 'Make FAFSA Corrections' on the 'My FAFSA' page. You must use your Federal Student Aid PIN to access your record online. If you need additional help with your SAR, contact your school's financial aid office or click the 'Help' icon on the FAFSA home page. If your mailing address or e-mail address changes, you can make the correction online.

Based on your EFC of 000000, you may be eligible to receive a Federal Pell Grant of up to \$5,730 for the 20XX-XX school year provided you have not met or exceeded the lifetime limit established for the Federal Pell Grant program.

Your Pell Grant eligibility is referenced at the bottom, if you qualify. The lower your EFC, the more money you qualify for, up to the maximum in 2016-17 of \$5,815.

Although you're instructed to use the "checklist" below, it's not formatted like a checklist; read everything below this instruction very carefully and do what it says! Your FAFSA is not considered "complete" until you do.



SECTION 3

# Financial Aid Award Letters

After you've applied to your target schools and completed the FAFSA, you'll begin to receive financial aid award offers from each college.

You may receive your award offers in a letter through the mail or email, or online through your college student account. Review these offers carefully to ensure that you understand your potential out-of-pocket expenses. Your School Counselor can help with that. It is also important that your parents/guardians review your award letter(s) to help you make this important decision. The financial award offers you receive from each school you have been accepted to, will vary. Your "net" or out-of-pocket cost to attend each school is likely to be an important factor in deciding which school to attend.

After you decide which school to attend, carefully respond to that school's financial aid offer; you will be asked to "accept or decline" each component of your aid package. You can accept some offers, but decline others, if you won't need it. Always accept "free" money – like scholarships and grants. And accepting work-study, if it's been offered is a good idea. It doesn't obligate you to find and take a work-study job, but accepting it will allow you to go that route, if you want to. Think carefully, and review the terms closely, before you accept any loans offered, as these must be repaid, with interest.

An example of an award offer, presented online through a student's college account, is provided below.

## Financial Aid

### Award Summary

#### Financial Aid Year 20XX-20XX

You are eligible to receive the awards listed below. Please review each award and corresponding message. You may Accept, Reduce and/or Decline any or all the awards that are currently available.

#### Awards - Academic Year

Award Description	Category	Offered	Accepted	Loan Details
Federal Pell Grant	Grant	5,645.00	5,645.00	
Federal Supp. Educ. Opp Grant	Grant	300.00	300.00	
State University Grant	Grant	5,472.00	5,472.00	
Federal Work Study	Work/Study	2,500.00	2,500.00	
Direct Sub Stafford Loan 1	Loan	5,500.00	5,500.00	<a href="#">Loan Details</a>
Direct Unsub Stafford Loan 1	Loan	3,337.00	3,337.00	<a href="#">Loan Details</a>
<b>Awards - Academic Year Totals</b>		22,754.00	22,754.00	

Currency in US Dollars

[Cost of Attendance Summary](#)

ACCEPT/DECLINE AWARDS

# Section 4 Help with Lift-Off: Scholarships

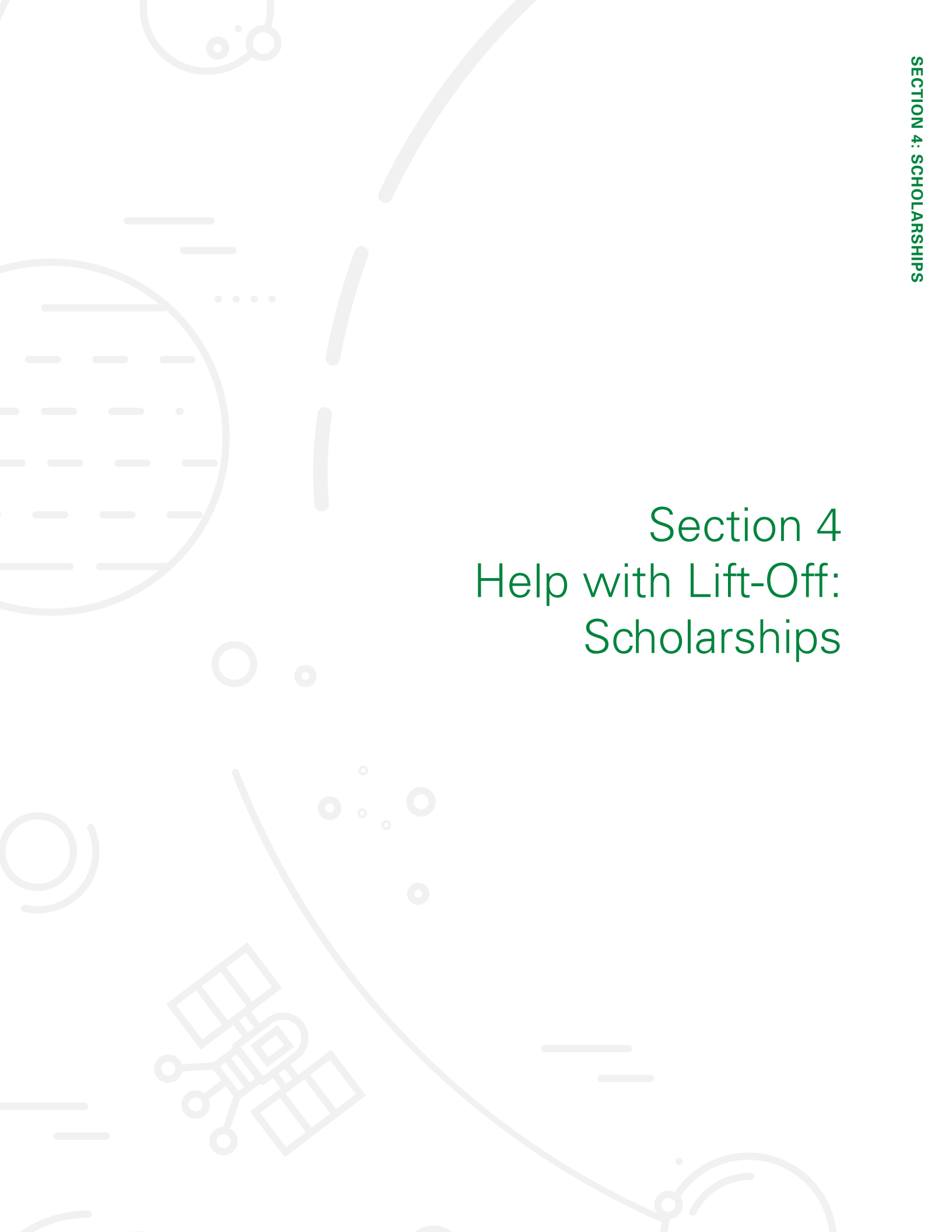

## Why Scholarships?

Securing scholarship funds is a great way to help pay for college costs. The following pages explain what scholarships are, how they work, and how you can apply.

Many scholarships are competitive, so this section provides advice on finding those that are right for you, crafting your application essay and submitting applications, so that you can maximize your chances of getting the award.



# The What, Where & How of Scholarships



## What is a scholarship?

Simply put, a scholarship is money given to students to help pay for their education. Unlike loans, scholarship money does not need to be paid back. Scholarships are awarded based on many different factors:

- Academic performance (also referred to as merit)
- Financial need
- Athletic performance
- Special talents and affiliations
- And more

Most scholarships require students to submit an application. The application may require an essay, a portfolio, a letter of recommendation or nomination by a teacher or Guidance Counselor, or other additional documents/creations.

## Where do I find scholarships that are right for me?

Most scholarship opportunities can be found online using powerful search engines based on a personal profile you complete on the site.

When you apply to the three Arizona public universities, your college application also serves as a scholarship application for merit-based scholarships at those colleges. Most universities/colleges in Arizona and across the country also administer numerous scholarships that require additional applications.

The Arizona Community Foundation administers numerous scholarships for which students can be considered by completing just one online application.

### Start your search with these websites:

- American Indian College Fund: [collegefund.org](http://collegefund.org)
- Arizona Community Foundation: [azfoundation.org](http://azfoundation.org)
- [collegescholarships.com](http://collegescholarships.com)
- Fastaid: [fastaid.com](http://fastaid.com)
- Fastweb Scholarship Search Engine: [fastweb.com](http://fastweb.com)
- Hispanic Scholarship Fund: [hsf.net/scholarships](http://hsf.net/scholarships)
- Sallie Mae Bank: [collegeanswer.com](http://collegeanswer.com)
- Unigo Scholarship Search Engine: [unigo.com/scholarships](http://unigo.com/scholarships)
- Northern Arizona University Scholarships: [nau.edu/finaid/aid-types/scholarships/](http://nau.edu/finaid/aid-types/scholarships/)
- Arizona State University Scholarships: [students.asu.edu/scholarships](http://students.asu.edu/scholarships)
- University of Arizona Scholarships: [scholarshipuniverse.arizona.edu/suha/Scholarships](http://scholarshipuniverse.arizona.edu/suha/Scholarships)

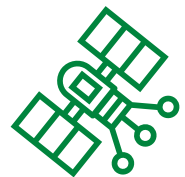
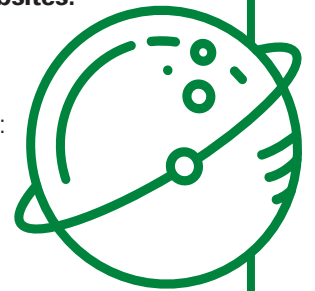

## How do I avoid scholarship scams?

Unfortunately, there are people who prey on aspiring college students with scholarship scams. Here are some red-flags to watch for:

- Winning a scholarship that you didn't apply for
- Companies that request personal identification information, such as a Social Security number or bank account information
- Scholarships that require a fee to apply

If you're unsure about a certain company or opportunity, check with your School Counselor.



## SECTION 4

# Writing a Personal Statement

Many college and scholarship applications require an essay or personal statement. But it can be hard to know where to start. Here are some do's and don'ts for writing a memorable personal statement.

## Choose a topic that will highlight you

- **Don't** focus on the great aspects of a particular college, the amount of dedication it takes to be a doctor or the number of extracurricular activities you took part in during high school.
- **Do** share your personal story and thoughts. Take a creative approach and highlight areas that aren't covered in other parts of the application, like your high school records.
- **Don't** try to cover too many topics. This will make the essay sound like a resume that doesn't provide any insight into your personality.
- **Do** focus on one aspect of yourself so the readers can learn more about who you are. Remember that the readers must be able to find your main idea and follow it from beginning to end. Ask a parent or teacher to read just your introduction and tell you what he or she thinks your essay is about.

## Show, don't tell

- **Don't** simply state a fact to get an idea across, such as "I like to surround myself with people with a variety of backgrounds and interests."
- **Do** include specific details, examples, and reasons to develop your ideas. For the example above, describe a situation when you were surrounded by various types of people. What were you doing? With whom did you talk? What did you take away from the experience?

## Use your own voice

- **Don't** rely on phrases or ideas that people have used many times before. These could include statements like, "There is so much suffering in the world that I feel I have to help people." Avoid overly formal or business-like language, and don't use unnecessary words.
- **Do** write in your own voice. For the above example, you could write about a real experience that made you feel you had to take action.
- **Don't** plagiarize. Admissions officers will be able to tell.

## Ask a teacher or parent to proofread

- **Don't** turn your essay in without proofreading it, and don't rely only on your computer's spell check to catch mistakes. Even the best spell-check programs aren't error-free.
- **Do** ask a teacher or parent to proofread your essay to catch mistakes. You should also ask the person who proofreads your essay if the writing sounds like you.

*Adapted from: [bigfuture.collegeboard.org](http://bigfuture.collegeboard.org)*

# Writing a Stand-Out Essay

Scholarship applications often require applicants to write a short (1-2 page) essay in response to specific prompts. Examples include:

- If you had the authority to change your school in a positive way, what specific changes would you make?
- Describe how you have demonstrated leadership ability both in and out of school.
- Pick an experience from your own life and explain how it has influenced your development.

The tips below can help you get started on a standout essay. Don't forget your English teacher is a great resource.

## Introduction (first paragraph)

**Tip:** Provide an overview of what you are going to talk about in the essay; be sure it is responsive to the essay prompt. If the essay is about you, give a brief description of your experiences, aspirations, family background, etc. Touch on why you want the scholarship.

## Body (paragraph 2-3)

**Tip:** Go into more detail on one of the topics listed in paragraph 1. For example, elaborate on your previous experiences, family and financial situation, volunteer work, employment, academic career, future goals, college plans, etc.

## Conclusion (last paragraph)

**Tip:** Close your essay with a wrap-up of why you should be considered for the scholarship; how your goals match those of the organization. Avoid stating, "In conclusion..." and don't regurgitate what you wrote in earlier paragraphs.

Keep in mind that all scholarship and college admission applications are different, so you will have to craft your essay to meet specific requirements and the expectations of the scholarship awarding organization. Look closely at the question/prompt on the application and research the organization giving the scholarship so that you can tailor your essay. Most importantly, be yourself! Essays serve as a glimpse into how your mind works and how you view the world.

*Adapted from: [estrellamountain.edu/students/scholarships/essay](http://estrellamountain.edu/students/scholarships/essay)*

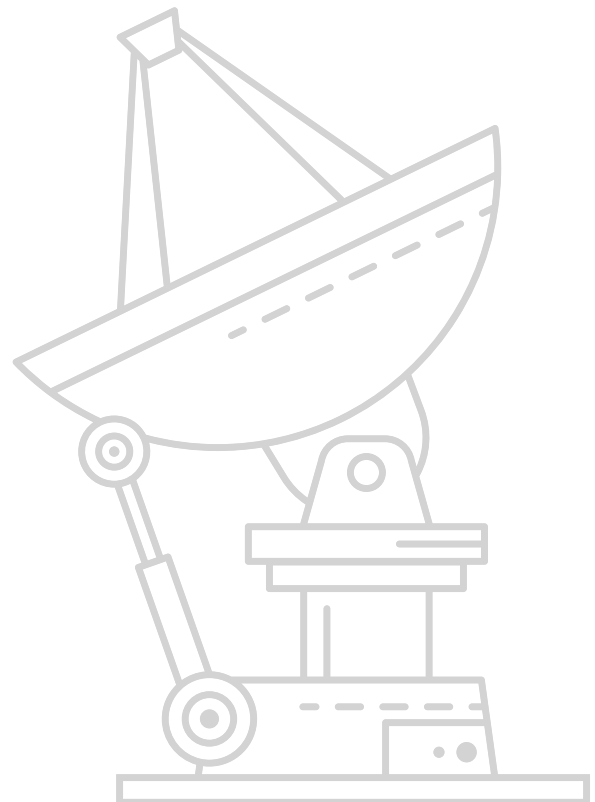



SECTION 4

# Letters of Recommendation

Many of your applications - to schools, for scholarships and jobs - will require that you provide letters of recommendation. A teacher, counselor, coach, supervisor or any other adult who will be able to share with the selection committee why you deserve to be chosen, can write these letters.

- Consider someone who can discuss your personal character, strengths and challenges; someone who knows you and has experience interacting with you. If you need more than one letter for the same application, select individuals familiar with different aspects of your life to write them (e.g., one teacher, your supervisor at work and your soccer coach).

Who you might ask for a letter of recommendation:

---



---



---



---

- Always ask the individual ahead of time if they would be able to write a recommendation letter for you. You do not want to miss an application deadline because the person writing your letter was too busy. Give them at least two weeks' notice (three to four is even better).
- Provide the individual with a list of your honors, awards, athletic involvement, community service, and academic record as well as any other pertinent information you would like included in the letter. Giving the individual a copy of your resume is an efficient way to provide that information. If a specific form or format is required for the letter of recommendation, include that information in your request. (see the next page for a sample request form)
- Provide the individual(s) with the necessary forms, addresses, and/or stamped, addressed envelopes.

Follow these tips for making the recommendation letter process as smooth possible for both you and your letter writers.



- Follow up with the individual to ensure they don't need any additional information from you.
- Always write a thank-you note to anyone who writes a letter for you. Letters of recommendation take time, and people put a lot of thought and effort into them. You do not want to take them for granted.

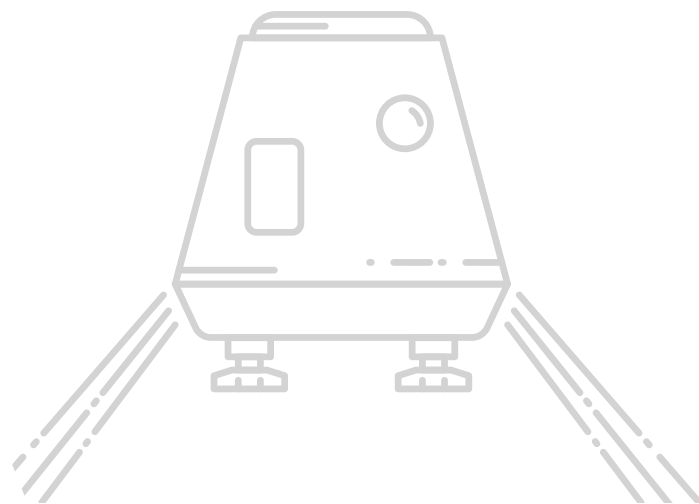







# Section 5

## One Small Step, One Giant Leap: Pursuing a Future in the Military

# Joining the Armed Forces

If you are interested in joining a branch of the U.S. military immediately after high school graduation, this section includes resources that may be helpful as you prepare to enlist. Time in the military can teach you a valuable trade; prepare you for a life-long career serving our country; or simply give you time to decide what you want to do next. It can be a valuable experience with good benefits and structure.

If you're not yet sure which branch to join, consider speaking with a recruiter in your area.

Before you become part of the military, there is one test that you'll need to take – the ASVAB. But there are websites that can help to prepare you for that. In the coming pages you'll find references for these and other helpful websites.



# General Information about Enlisting and the ROTC Alternative

If you are interested in enlisting in the military, the best, most up-to-date information can be found on the internet. Several helpful websites are described in this Section, along with the URL for each.



## Military Recruiters

A *military recruiter* can help answer questions about service, providing a positive but realistic assessment of opportunities. A recruiter's job is to find qualified candidates for his or her respective service and provide the candidates with information about – and reasons for – joining the military. Students interested in military service, are advised to talk with a recruiter for the branch of the military in which they are interested. Your high school counselor can tell you when military recruiters will be at your high school.

## ROTC Programs – an alternative to enlistment

ROTC stands for Reserve Officer Training Corps. It's a college program offered at over 1,700 colleges and universities across the United States that prepares young adults to become officers in the U.S. Military. In exchange for a paid college education and a guaranteed post-college career, cadets commit to

serve in the Military after graduation. Each service branch has its own take on ROTC and universities that offer ROTC may offer it for one, some, or all of the military branches. More information about ROTC is available on these websites:

- [todaysmilitary.com/training/rotc](http://todaysmilitary.com/training/rotc)
- [bestcolleges.com/resources/rotc-programs](http://bestcolleges.com/resources/rotc-programs)

## ASVAB

The Armed Services Vocational Aptitude Battery (ASVAB) is a multiple-choice test, administered by the United States Military Entrance Processing Command, and used to determine qualification for enlistment in the United States Armed Forces. Just like any other test, it is recommended that students prepare for the ASVAB. Learn more about the ASVAB, and how to prepare for it, by visiting the sites below.

### For general information:

- [official-asvab.com](http://official-asvab.com)

### For online ASVAB test prep:

- [march2success.com](http://march2success.com)
- [asvabtutor.com](http://asvabtutor.com)
- [asvabpracticetests.com](http://asvabpracticetests.com)

## Delayed Entry Program

The Delayed Entry Program (DEP), also called the Delayed Enlistment Program (or the Future Soldiers Program in the Army), is a program in which individuals who want to enlist in the United States Armed Forces are placed before they ship out to Basic Training or "boot camp." Students who plan to join the military immediately following high school will likely enlist through the DEP. To learn more about DEP, visit the site below.

- [girightshotline.org](http://girightshotline.org)

# General Information about Enlisting and the ROTC Alternative (Cont.)

## Military Career Opportunities

Jobs in the military vary in the type of work as well as level of responsibility, yet each job is essential to accomplishing the overall mission of defending our country. Explore the different types of career opportunities available to service members, learn about the compensation they can expect to receive, and find out how to transfer careers to the civilian sector on the website below.

- [todaysmilitary.com/working](http://todaysmilitary.com/working)

## Boot Camp Preparation

Going in physically and mentally strong to basic training will provide you with the confidence you need to successfully complete the training. If you wait until the first day of basic training to start preparing, you will fight an uphill battle. The requirements and training for each branch of the military are different. To learn more about the differences and to get tips on how to prepare, check out the sites below:

- [military.com/military-fitness/workouts/prepare-yourself-for-boot-camp](http://military.com/military-fitness/workouts/prepare-yourself-for-boot-camp)
- [military.com/military-fitness/army-basic-training/getting-prepared-for-bootcamp](http://military.com/military-fitness/army-basic-training/getting-prepared-for-bootcamp)
- [breakingmuscle.com/learn/how-to-prepare-your-mind-and-body-for-basic-training](http://breakingmuscle.com/learn/how-to-prepare-your-mind-and-body-for-basic-training)

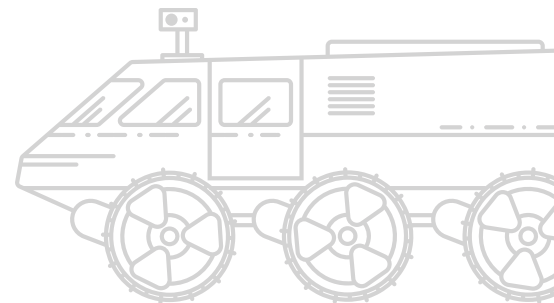

The background features a light gray satellite in the lower-left quadrant, with several curved lines representing orbital paths or trajectories. Various geometric shapes, including circles, arcs, and horizontal lines, are scattered across the page, creating a technical and futuristic aesthetic.

## Section 6 Entering Orbit: Going into the Workforce



# When Entering the Workforce is Your First Step...

If you plan to begin working immediately after graduation, this section will help you get started. It might be a full-time job to give you time to better figure out your long-term plan, or a part-time gig to help you pay for college. Whichever option you're headed for, you'll find valuable resources in the coming pages.

Most jobs that you apply for will require either a resume or application, and perhaps both. Use the form on the next page to help you get organized. In the pages after that, you'll find tips for creating your resume and cover letter, along with samples of each.

On the last page of this section, you will find a table for tracking your job applications - a helpful tool to ensure nothing falls through the cracks.

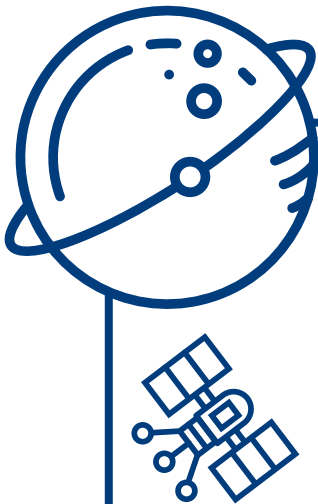

If you're not sure what type of job to pursue, here are some websites that might help:

- [mynextmove.org/explore/ip](https://mynextmove.org/explore/ip) – a career interest assessment helps you figure out what kinds of careers you are most likely to enjoy and be good at
- [bls.gov](https://bls.gov) – provides information on the outlook for various careers, including salary, demand, educational requirements, etc.



# Resume and Job Application Information

Fill out the form on this page and you'll have all of the information you need, in one place, to fill out job applications. You can also use these details as the basis for your resume.

Full legal name: \_\_\_\_\_ Date of birth: \_\_\_\_\_

Citizenship: \_\_\_\_\_ If not a U.S. citizen, specify country: \_\_\_\_\_

If you are a Permanent Resident, Refugee, or Asylee, date of status approval/issuance: \_\_\_\_\_

Other Visa Type & Date: \_\_\_\_\_

Permanent mailing address: \_\_\_\_\_

Current address, if different from permanent address: \_\_\_\_\_

Permanent phone number: \_\_\_\_\_ Cellular or message phone number: \_\_\_\_\_

Email address: \_\_\_\_\_

Social Security number: \_\_\_\_\_ - \_\_\_\_\_ - \_\_\_\_\_

High school academic history (If you attended more than one, list most recent)

Name of high school: \_\_\_\_\_ City, State of high school: \_\_\_\_\_

Dates attended: \_\_\_\_\_ Date of high school graduation (month & year): \_\_\_\_\_

Cumulative GPA: \_\_\_\_\_ ACT Score: \_\_\_\_\_ SAT Score: \_\_\_\_\_

Athletics, Clubs and Organizations				
List name of club/sports team	List your role/position each year			
	Freshman	Sophomore	Junior	Senior

Community Service			
Name of the organization/contact	Description of volunteer service	Number of hours of service	Date(s) of service

Honors & Awards		
Name and Date of Award	Reason for Award/Honor	Sponsor

Work Experience (list most recent examples first)				
Start & End Date of employment	Job Title	Company Name	Business Address	Brief description of duties

References (Non-relatives who potential employers can contact to explore whether you would be a good hire)				
Name	Title	Address (Street, City, State, Zip Code)	Phone Number	Email address



## SECTION 6

# Creating a Resume

Both the content and format of your resume are important. It doesn't matter how great your work or life history is—if your resume is poorly formatted, hard to follow or has typos, you won't be considered for employment. The sample provided on the next page is one clear, well-organized example you can follow.

## The basic elements of a resume

- 1. Heading:** Include your name, address, email address and phone number. Make it stand out and make an impression by using large, bold font. Make sure your email is professional (not starwarsfan@hotmail.com or crzychik@aol.com for example).
- 2. Education:** List all degrees completed or in progress. As a high school student, include your GPA if it is 3.0 or above and list courses that reflect your work ethic and high aspirations, such as AP or dual enrollment courses and any courses relevant to the position for which you are applying. After you complete your college degree, do not include your high school information.
- 3. Experience:** Include your job title, the employer, the location (city and state, at minimum), and the dates of employment for each job listed. Include a brief description of your achievements/responsibilities. Ideally, paid work and unpaid work (community service) are listed separately.
- 4. Honors/Awards/Scholarships:** Optional – Include the name of the organization that bestowed the honor/award and the date. Only include scholarships based on merit, not financial need.
- 5. Special Skills/Highlights:** Optional – List any unique, relevant or necessary skills not reflected in education or experience (e.g., foreign language fluency, computer program expertise, etc.).
- 6. References:** Be sure to get permission from anyone you use as a reference before using their name, and provide them with a copy of your resume. Do not use relatives as references. References can be on a separate sheet of paper, formatted just like your resume.



# Sample Resume



## EMILY S. JONES

3328 West Parker Avenue, Mytown, Arizona 85000  
928-555-5555 | emily.jones@gmail.com

### EDUCATION

May, 20XX High School Diploma with a 3.37 GPA, *ABC High School 333 S. School St., Mytown, AZ*

### SPECIAL COURSES

Spanish I–III ♦ Marketing I ♦ AP Chemistry ♦ AP Computer Science ♦ Word Processing

### WORK EXPERIENCE

September 20XX – Present **Pharmacy Sales Associate**, *Walgreens, 123 Main St., Mytown, Arizona*

- Duties include cashiering, customer service in English and Spanish, answering the phone and assisting or transferring callers as needed, general clean-up and other duties as assigned.

May – August 20XX **Order-Taker/Cashier**, *McDonald's, 201 N. Country Dr., Mytown, Arizona*

- Duties included accurately taking customer orders in English and Spanish, entering them into electronic order system, handling customer payments including providing correct change and handling credit card transactions.

### EXTRACURRICULAR ACTIVITIES & AWARDS

20XX – current S.A.D.D. (Students Against Drunk Driving) – member  
20XX – 20XX Club R.I.F (Reading Is Fundamental) – secretary  
20XX – 20XX Skyline Ambassadors (student service club) – member  
August 20XX “I Care” Customer Service Award – McDonald’s

### COMMUNITY SERVICE

St. Mary’s Food Bank – canned food drive, November 20XX, November 20XX  
Sunday School Teacher – pre-school class, 20XX-20XX  
Service Saturday – ABC High School, April 20XX

### REFERENCES

Ms. Wonder Woman, History Teacher, ABC High School, (602)791-4808, wonder.woman@ABC.org  
Mr. Ralph Peterson, Manager, McDonald’s, (928) 555-1555, r.pete@mcd.com



## SECTION 6

# Creating a Cover Letter

If you have the opportunity to add a cover letter to an employment application, do it! It gives the employer a better sense of your communication skills, as well as a sense of your personality and enthusiasm for the job. Some employers require a cover letter. This section provides tips for writing an excellent cover letter.

## The basic elements of a cover letter

1. **Greeting:** Address your cover letter to the proper person.
2. **Opening:** Write a personable, inviting opening paragraph that highlights how your skills are a perfect fit to the job.
3. **Hook:** Highlight your achievements as they relate to the job you're applying for.
4. **Skills:** Highlight additional relevant skills, such as computer languages or certifications.
5. **Close:** Briefly recap your strengths as a candidate, and include your contact information.



If a cover letter is required to apply for a job and you don't include one, your resume or application, no matter how good, will not even be looked at.

# Sample Cover Letter



EMILY S. JONES

3328 West Parker Avenue • Mytown, Arizona 85000 • (928) 555-5555 • emily.jones@gmail.com

[Date]

Ms. Rhonda West, Customer Service Manager  
Acme Inc.  
123 Corporate Blvd.  
Sometown, AZ 85000

**Re: Customer Service Representative Opening (Ref. ID: CS300)**

Dear Ms. West:

I was excited to see your opening for a customer service representative, and I hope to be invited for an interview.

I recently graduated from high school, where I was a member of the Skyline Ambassadors Club for two years. Skyline Ambassadors plan and complete at least one service project each month, and through those I gained considerable experience working with and for people from all walks of life. After school and on weekends, for over two years, I have been working in positions that require exceptional customer service skills. At MacDonalds, I was awarded the "I Care" Customer Service Award after just three months in the position. At Walgreens, because of my fluency in Spanish, I am regularly called upon to assist Spanish-speaking customers, and based on the posting for this position, I believe you will find my skills in this area very useful in your company.

Although I have not been out of high school long, in the part-time positions I have held, as my supervisors will attest, I have already demonstrated the ability to resolve a variety of issues (such as billing disputes and dissatisfied or angry customers) and I consistently met all goals set by my employers. I have also demonstrated a strong sense of responsibility and maturity as evidenced by my successful completion of rigorous AP courses, leadership roles in extracurricular activities and my high GPA (3.37).

In addition to my work experience, I gained considerable customer service and communication skills during my tenure as secretary of the Reading Is Fundamental (RIF) Club at my high school. In that role, I regularly contacted elementary schools and non-profit after-school programs for youth to discuss possibilities for collaboration. After identifying ways in which our goals overlapped and how working together could be mutually beneficial to our organizations, I worked with the RIF Sponsor and other officers to work out the important details to ensure success.

I also bring to the table strong computer proficiencies in Microsoft Word, Excel, Powerpoint and Access. My comfort with computers and various database operations will, I am confident, allow me to quickly learn any proprietary software your company may use. Please see the accompanying resume for details of my experience and education.

I am confident that I can offer you the customer service, communication and problem-solving skills you are seeking. I will follow up with you in a few days to answer any preliminary questions you may have. In the meantime, you may reach me at (928) 555-5555 to schedule an interview. Thank you for your time—I look forward to learning more about this opportunity!

Sincerely,

Emily Jones

Enclosure: Resume



The background features a light gray satellite in the lower-left quadrant, surrounded by various geometric shapes including circles, lines, and arcs, suggesting a space or technology theme.

# Section 7 Reaching for the Stars: Information for Undocumented Students

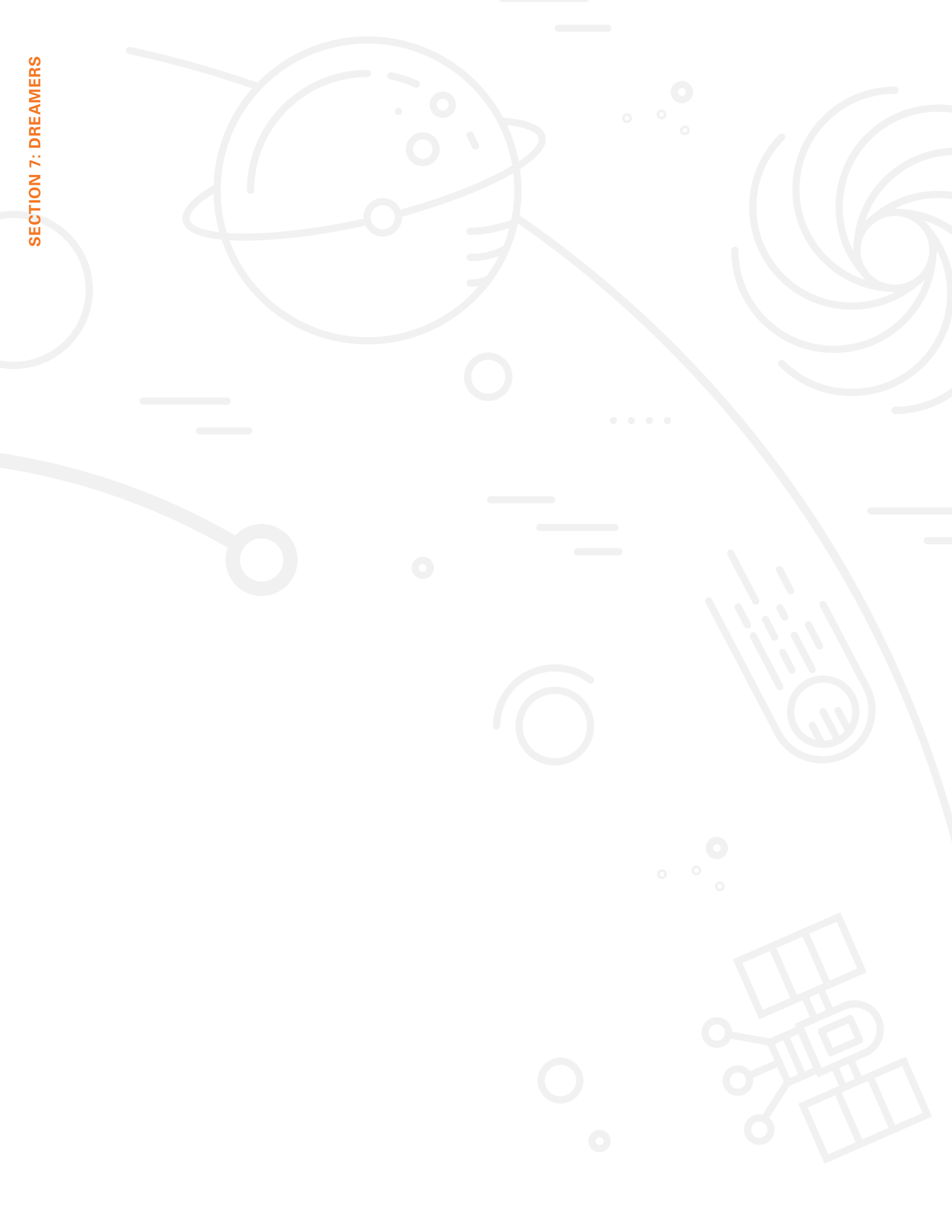

# A Pathway to College for ALL Students



If you want to continue your education beyond high school, your documentation status should not hold you back. Attending a university, community college or technical school is within your grasp. If you are not documented, however, your path through the application and financing process will be different from other students.

There are a lot of variables to consider when you are deciding which college to attend and figuring out what the cost will be. While answers about residency, tuition, and eligibility for specific scholarships are not always simple, this section provides general information on resources available to help you find a school and pay for your education.

**DREAMers:** Individuals who would have qualified under the DREAM Act are often referred to as DREAMers. The term has been used to define individuals in the U.S. who were brought to the country at an early age without documentation but have assimilated to the U.S. culture and have been educated by U.S. school systems. At this time, this term does not define a documentation status, but instead, it is sometimes used to define an identity or a community. Students who are undocumented and students who have DACA status may both identify as DREAMers, or may choose not to. Some people do not use the term DREAMer because it separates young undocumented immigrants who entered the country as children from other immigrants, further marginalizing some immigrants.

**Deferred Action for Childhood Arrivals (DACA) Program:** A kind of administrative relief from deportation. The policy allows youth under 31 years old as of June 15, 2012, who came to the United States before the age of 16 without documentation, and have been educated by U.S. school systems, the opportunity to remain in the U.S. by following specific guidelines. The DACA program has undergone changes since it was created. For up-to-date information on DACA visit [uscis.gov](http://uscis.gov) and search the site for “DACA.”

**DACAmented:** An informal term used to indicate the documentation status of a person who applied and received relief from deportation through DACA.



“Never let it be said  
that to dream is a  
waste of one’s time,  
for dreams are our  
realities in waiting. In  
dreams, we plant the  
seeds of our future.”  
–Author Unknown



## SECTION 7

# Four Things You Need to Know about College

If you're a high school student who's undocumented – that is, you were born outside the United States and you're not a U.S. citizen or legal resident – you probably have a lot of questions about going to college. Here are some important facts.

### 1. You can go to college

The first thing you should know is that no federal law prevents U.S. colleges from admitting undocumented students. And only a few states have placed any kind of restrictions on undocumented students attending public colleges and universities. In Arizona, all students can attend public colleges or universities, but the state prohibits in-state tuition rates for undocumented students. In most cases, colleges set their own rules for admitting undocumented students, so you should research the policies of the colleges you are interested in attending.

You should also know that undocumented students cannot receive federal financial aid for college – the type of aid on which many college students rely. However, undocumented students can get financial aid or scholarships for college in other ways. This is covered under the heading “Undocumented Students: Questions and Answers about Paying for College” later in this section.

### 2. You are not alone

You're the one who will have to put in the work it takes to get to college – but building a support network is key. Start with your family. Make sure they know you want to go to college. Talk with them about your options for choosing a college and paying for your education.

You can also seek advice from trusted teachers and counselors at your high school. Along with giving you guidance, they might be able to put you in touch with other undocumented students who have successfully enrolled in college or with college admission counselors who can help you.

If you're worried about telling teachers and counselors that you're undocumented, be aware that, by law, school officials cannot disclose personal information about students – including their immigration status.

### 3. You can find a college that fits you

As you look for colleges that match your wants and needs, you might want to find out if the colleges you're interested in have programs, student organizations or centers that support first-generation immigrant students. You may consider applying to private colleges, rather than public institutions. Reviewing college websites and publications is a good place to start.

### 4. You can find resources to help you

This section of the guide will provide you with general information on paying for college, filing the FAFSA as a DACA recipient, and applying for one of the three public universities in Arizona. The majority of the information in this section comes from **bigfuture.collegeboard.org** and from **scholarshipsaz.org**. Visit these websites for more information.



You can attend an Arizona college or university.



# Questions and Answers about Paying for College



If you're an undocumented student, you probably have questions about college costs. Here are answers to some common questions about paying for college.

- **Do colleges offer financial aid or scholarships to undocumented students?**

Yes, some do. Private colleges often have special funds available. To apply for this financial aid, you may have to fill out the CSS/Financial Aid PROFILE or the college's own forms. Check with the admission or financial aid office at each college you are interested in to find out its requirements.

- **Am I eligible for scholarships?**

Yes, you just need to find ones that you qualify for. Start by talking to your Guidance Counselor and checking out the Scholarship Resources page on the Mexican American Legal Defense and Educational Fund (MALDEF) at [maldef.org](http://maldef.org), and at [scholarshipsaz.org](http://scholarshipsaz.org). There are many scholarship opportunities, and some private scholarship organizations allow undocumented students to apply. There are even a few scholarships specifically for undocumented students. Be sure to look into local scholarships offered by community groups, such as the Kiwanis, that might be open to all students living in the local community.

- **Can I get federal financial aid?**

No. You can't get federal financial aid unless you're a U.S. citizen or eligible noncitizen. This means you should not fill out the Free Application for Federal Student Aid (FAFSA).

- **Can I get a Pell Grant?**

No. Pell Grants are a type of federal financial aid.

- **Can I get financial aid from my state?**

No, Arizona does not offer financial aid to undocumented students.

- **Do I pay the in-state or out-of-state rate at a public college in my home state? What about in a different state?**

Arizona law currently prohibits in-state tuition rates for DACA students and for undocumented students. DACA and undocumented students will pay the "non-resident" tuition rate. For up-to-date information on the status of tuition rates for DACA students contact the colleges' financial aid or residency offices.

- Also, tuition rates at many private colleges across the country do not differ between in-state and out-of-state students (Grand Canyon University is an example of a private college in Arizona). Because of these differences in policies by college, you will want to call each institution to determine if you qualify for in-state tuition rates. Upon admission, it is very important to review financial aid award letters carefully. In some cases, private colleges or out-of-state colleges may give students better offers than public colleges in Arizona. You can find a list of "undocumented friendly colleges" as well as guidance on what questions to ask on [scholarshipsaz.org](http://scholarshipsaz.org).





## SECTION 7

# FAFSA Information

The FAFSA process can look very different for DACAmented students, citizen students with undocumented parents, and undocumented students.

### DACAmented Students

DACAmented students are NOT eligible for federal aid, and in Arizona, are not eligible for state-based aid either. However, if a college or scholarship requests it, a DACAmented student can file the FAFSA to demonstrate financial need for institutional and private scholarships.

DACAmented students can use their SSN to create an FSA ID and to complete the FAFSA. During the FAFSA process, it is important to represent your status accurately. Students should select “no, I am not a US Citizen or eligible non-citizen.”

Keep in mind that students will receive a rejection letter because they do not qualify for aid, but this will not affect their EFC. The EFC can be used to demonstrate need for institutional and private scholarships.

### Citizen Students with Undocumented Parents

If students have an undocumented parent, they must manually enter parental income information into the FAFSA. Do not use the IRS Data Retrieval tool.

Because undocumented parents do not have a SSN they cannot create an FSA ID. Parents must print, sign and mail in the signature page. You only have to send the signature page, not the whole application. The bar code on the signature page will match the student’s application.

### Undocumented Students

Students without a SSN cannot submit the FAFSA. Some scholarships request that students print out the FAFSA and submit it to demonstrate financial need. The College Board’s CSS Profile can also serve as a tool to demonstrate need.

*Source: Scholarships A-Z*

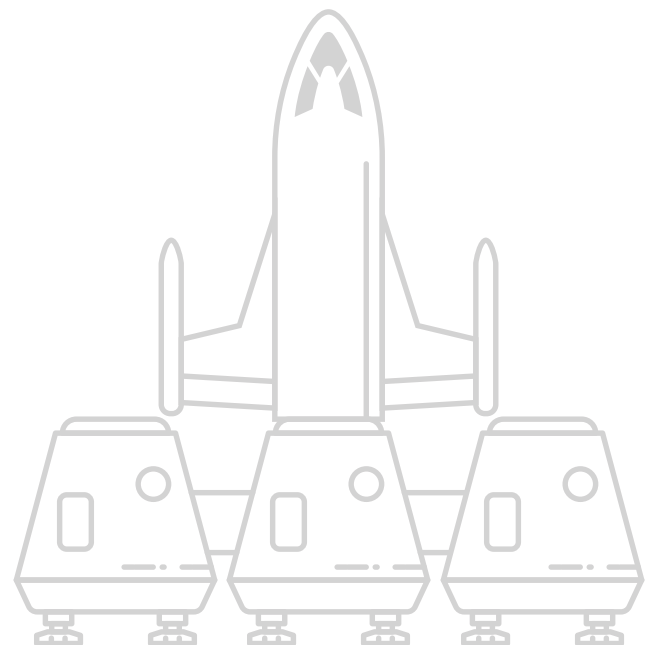

# Section 8 Final Systems Check

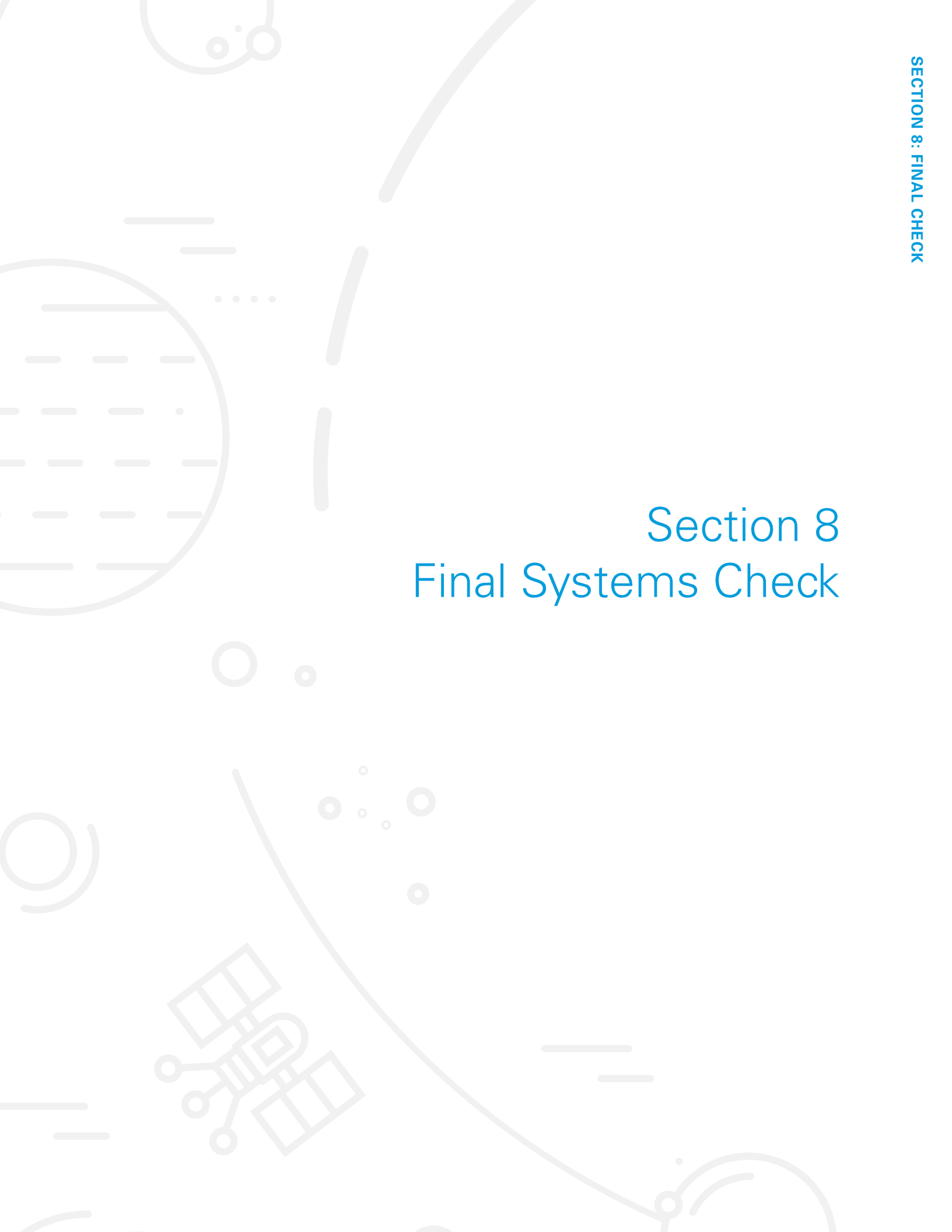

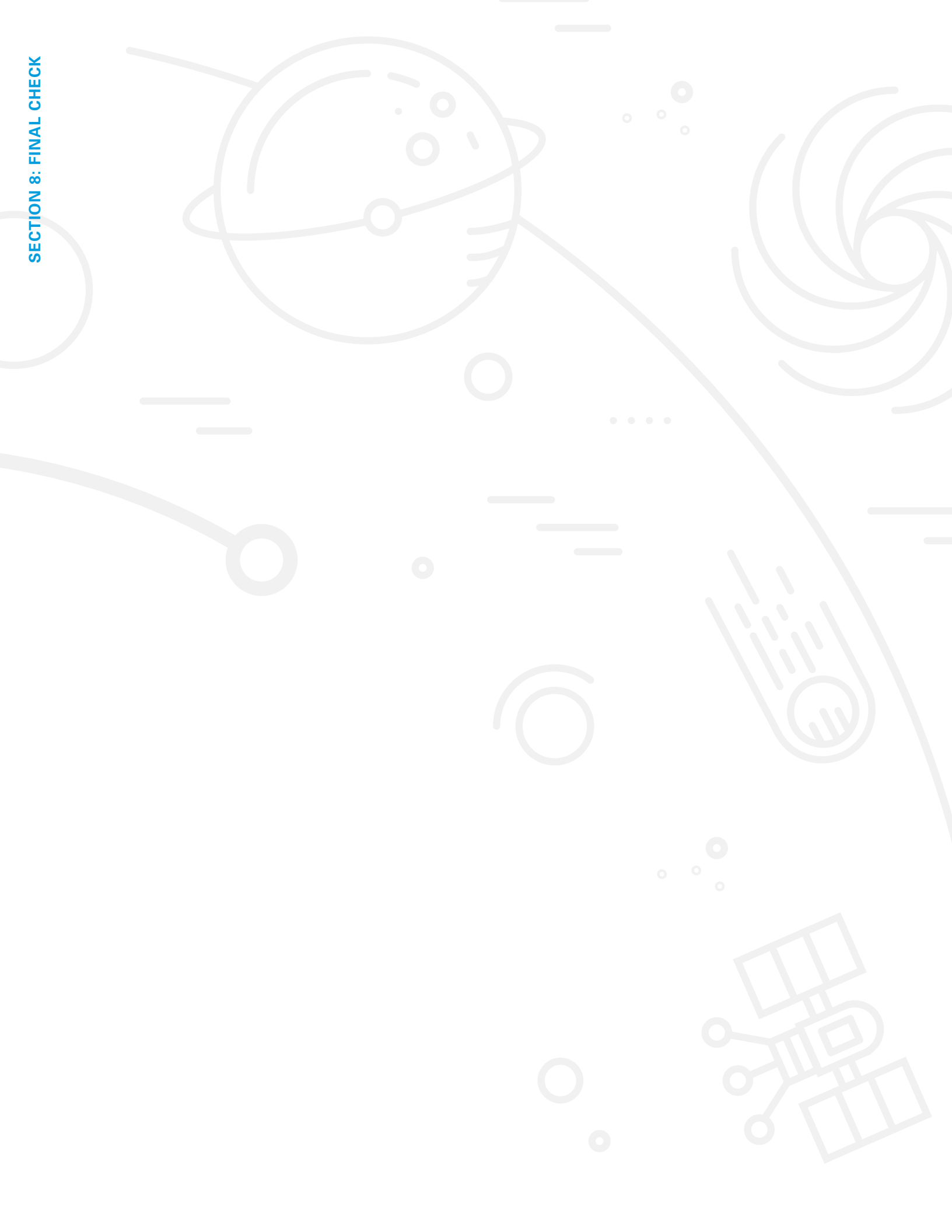

# Final Checklist



As you prepare to take those final steps toward your higher education goals, don't forget to keep your School Counselor informed. He/she will want to know:

What college you are going to attend: \_\_\_\_\_

What are the scholarships you have been awarded: \_\_\_\_\_

\_\_\_\_\_

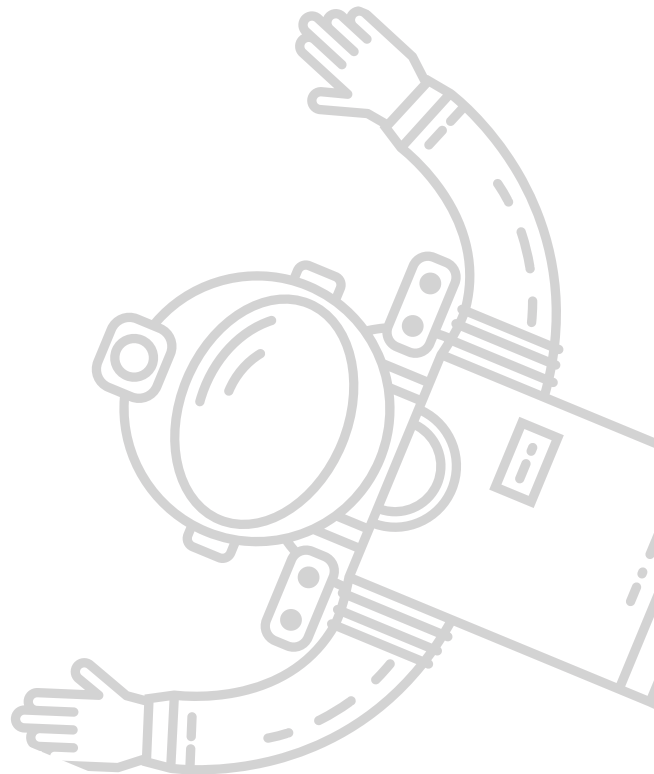



## SECTION 8

# Glossary

There are a lot of acronyms and confusing terms on the road to college. Here are a few that you might be wondering about. If there's one you don't see listed here, check with your Guidance Counselor for assistance.

**2+2/3+1 programs:** A postsecondary pathway in which students begin at the community college where they complete general educational requirements over 2 or 3 years and then transfer to a university (for the remaining 1 or 2 years) to complete a bachelor's degree.

**ACT/SAT:** Standardized college entrance exams. Many colleges and universities ask for ACT or SAT scores as part of the application process.

**Admission:** Notification from the college to which you applied that you are accepted. Students must respond, by the given deadline, to inform the college if they will accept the offer. Students accepted to multiple schools will want to compare their financial aid packages to help them decide which school to attend.

**Advisor:** A college staff member or professor who helps a student plan and complete a course of study at a college or university.

**Application:** A form that must be filled out to be considered for entry into university, community college, technical school, to be considered for a scholarship, and, in many cases, to be considered for a job.

**Associate's degree:** A degree granted after successful completion of a course of study

requiring approximately 60 credits, typically by a community or junior college. Full time community college students taking 15 credits per semester can generally finish an associate's degree in two years (also known as AA or AS degree, short for Associates of Arts and Associates of Science).

**ASVAB:** A test to determine qualification for enlistment in the U.S. Armed Forces. It stands for Armed Services Vocational Aptitude Battery.

**Award Letter:** Notice from a school of the amount and type of financial aid that the school is willing and able to provide a student.

**Bachelor's degree:** A degree earned for a course of study that normally requires 120 to 130 credits, involving specific classes related to the student's major. Full time students ideally complete a bachelor's degree in four years, although changing majors, transferring institutions, taking fewer than 15 credit hours per semester and/or taking courses that don't count toward one's declared major, can make it take longer (also known as BA or BS, short for Bachelor of Arts and Bachelor of Science).

**Certificate:** An official document attesting to a particular fact or accomplishment. In the postsecondary realm, students complete a series of specified courses, and sometimes an internship, and typically pass a test, to obtain certificates in specific trades or areas of expertise required to work in those fields. Examples include welding, medical technology, auto mechanics, massage therapy, and court stenography.

**Community college:** A public postsecondary institution that offers courses to residents in the surrounding area. Students may attend community colleges to obtain associate's degrees or technical certificates, or may take courses there towards a bachelor's degree, before transferring to a four-year university (2+2 or 3+1 pathway). Students can also take courses to enhance their skills in an area, or just for fun.

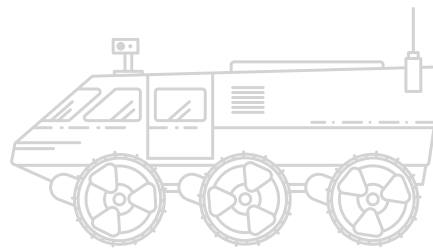

**Cost of Attendance (COA):** The total cost of going to college, including tuition, fees, room and board, books, transportation, and personal expenses.

**Deferment:** A period in which payment is not required. In the postsecondary realm, students can obtain deferment on paying their enrollment deposit as well as on paying interest and/or principal on student loans. Deferments do not last forever. Eventually these payments must be made.

**DREAMers:** Individuals who would have qualified under the DREAM Act are often referred to as DREAMers. The term has been used to define individuals in the U.S. who were brought to the country at an early age without documentation, but have assimilated to the U.S. culture and have been educated by U.S. school systems. Not all immigrant youth identify as DREAMers.

**Deferred Action for Childhood Arrivals (DACA) Program:** A kind of administrative relief from deportation. The policy allows young children (under the age of 16) who came to the U.S. without documentation, and have been educated by US school systems, the opportunity to remain in the U.S. by following specific guidelines.

**Early action:** When a student applies for admission to a college by an early deadline (before the regular admission deadline) and receives notice of acceptance, denial, or deferment with no obligation to the university to enroll.

**Early decision:** When a student applies for admission to a college by an early deadline (before the regular admission deadline), with the understanding that if accepted, the student must enroll in that school. Students should apply for early decision only to their first choice school.

**Expected Family Contribution (EFC):** The portion of a family's financial resources that should be available to pay for college, based on a federal formula using the

information on the FAFSA (Free Application for Federal Student Aid).

**FAFSA:** The Free Application for Federal Student Aid is an online form submitted annually by current and prospective college students (undergraduate and graduate) in the United States to determine eligibility for student financial aid. Students who are eligible to file the FAFSA should complete it every year.

**Federal Student Aid (FSA) ID:** A user name and password used by current and prospective students and their parents to log into U.S. Department of Education websites including the FAFSA website. The ID is used to sign documents electronically (it has the same legal status as a written signature).

**Fee waiver:** Permission to not pay a fee, based on meeting some requirement or condition. In the postsecondary realm, waivers of college application fees and ACT or SAT fees are often available for students based on financial need.

**Financial aid package:** The amount and types of federal, state, and college aid that a college/university offers to a student it has accepted, to offset the cost of attendance at their school. Also referred to as Award Letter. Depending on the package, sometimes it can be cheaper for a student to attend an expensive school because more aid is offered to offset the cost. This is why it is important to apply to the schools you want to attend, even if you don't think you can afford it. There are different types of aid including loans, work-study, scholarships, and grants.

**Four-year University:** A postsecondary institution/school that offers undergraduate (bachelor's) degrees. Many four-year universities also offer graduate (master's) degrees.

**Full-time student:** A student who enrolls in at least a minimum number (determined by your college or university) of credit hours or courses.



## SECTION 8

# Glossary

**Grade point average (GPA):** The average of all of the course grades you have received in high school, or in college, on a four-point scale.

**Ivy League:** A group of long-established colleges and universities in the eastern U.S. having high academic and social prestige. It includes Harvard, Yale, Princeton, Columbia, Dartmouth, Cornell, Brown, and the University of Pennsylvania.

**Letters of recommendation:** Letters of endorsement (often from high school teachers/staff) written on a student's behalf during the college and/or job application process.

**Major:** A concentration of study focused on a discipline, which requires completion of specific courses.

**Minor:** A college or university student's declared secondary academic discipline during their undergraduate studies.

**Orientation:** A meeting/event many colleges offer (hours or days-long) where incoming students and parents/guardians receive information about registering for classes, meet their advisor, and learn about school resources and policies.

**Pell grant:** Money from the U.S. government to support a student's education that does not have to be paid back. Pell grants are awarded to U.S. citizens and legal residents based on financial need and timeliness of completing the FAFSA.

**Placement test:** Colleges and universities may require students to take tests to determine the appropriate level college math and/or English class.

**Postsecondary education:** The broadest term to describe any education beyond high school, including, community college, university, technical school, etc.

**Residence hall:** A building primarily providing living/sleeping quarters for large numbers of students. Also known as a dorm or dormitory and often referred to as "on-campus housing."

**Resident:** A student who lives in and meets the residency requirements for the state where a public university is located. Tuition at public universities often is more expensive for non-residents.

**Resume:** A brief account of a person's education, qualifications, and previous experience, typically sent with a job application.

**ROTC:** Program to train college students to become officers in the U.S. Armed Forces. Stands for Reserve Officers' Training Corps.

**Room & board:** The cost of a room in a dormitory and a dining hall meal plan at a college or university.

**Scholarship:** Money to support a student's education that does not have to be paid back. Scholarships are awarded based on academic, athletic, artistic, or other types of achievements, affiliations or competitions.

**Student Aid Report (SAR):** The SAR summarizes the information included on the Free Application for Federal Student Aid (FAFSA). The SAR provides the Expected Family Contribution (EFC), which is used to determine whether a student is eligible for a federal Pell Grant and other federal aid.

**Student loan:** Money a student borrows to help pay for college, which must be paid back. Subsidized loans are offered to students who qualify through the FAFSA. The federal government pays the interest while the student is in college. There are also unsubsidized loans where interest begins accruing as soon as the loan is accepted.



**Summer bridge programs:** Programs offered by many universities and some community colleges, which occur in the summer between high school graduation and fall transition to college, which offer students accelerated, focused learning opportunities that can help better prepare them to succeed in college.

**Technical school:** A general term used for a college that provides mostly employment-preparation skills for trained labor, such as welding and culinary arts. These programs generally take no more than two years to complete. Examples include the Le Cordon Bleu Institute, Universal Technical Institute and DeVry.

**Transcript:** An official academic record from a specific school. It lists when you attended, the courses you have completed, grades, and sometimes test scores. Universities, colleges and technical schools usually require high school transcripts be submitted as part of the application process.

**TRiO Programs:** Federal outreach and student support service programs at the middle school, high school and college level to assist students with understanding of basic college requirements, and to motivate students toward successful completion of postsecondary education.

**Tuition:** The amount of money charged for instruction/classes at postsecondary institutions (see also – cost of attendance).

**Undeclared/undecided:** Term to describe a student who is unable or not ready to select a major at a college or university. Colleges typically ask students to pick their major by the end of their sophomore year.

**Work study:** A federal program that provides the opportunity for college students to work part-time jobs (often on the campus of the school they attend) to earn money to pay educational expenses. Students receive compensation in the form of a paycheck, much like a traditional job. Students must submit the FAFSA to be considered for work-study positions.



SECTION 8

# Username and Passwords

**WARNING:** Write usernames and passwords here, with or without encryption, at your own risk. Your password is the electronic equivalent of your signature. • Treat your passwords as you would treat any piece of personal and confidential information by taking measures to keep them confidential. If you choose to write your usernames and passwords here, keep tight control of this Guide at all times and if someone learns your password, or you lose this book, you should immediately change your password(s).

Name of site:		Why I use it:	
<b>Username</b>		<b>Password</b>	
Web address:			

Name of site:		Why I use it:	
<b>Username</b>		<b>Password</b>	
Web address:			

Name of site:		Why I use it:	
<b>Username</b>		<b>Password</b>	
Web address:			

Name of site:		Why I use it:	
<b>Username</b>		<b>Password</b>	
Web address:			

Name of site:		Why I use it:	
<b>Username</b>		<b>Password</b>	
Web address:			

# More Usernames and Passwords



Name of site:		Why I use it:	
<b>Username</b>		<b>Password</b>	
Web address:			

Name of site:		Why I use it:	
<b>Username</b>		<b>Password</b>	
Web address:			

Name of site:		Why I use it:	
<b>Username</b>		<b>Password</b>	
Web address:			

Name of site:		Why I use it:	
<b>Username</b>		<b>Password</b>	
Web address:			

Name of site:		Why I use it:	
<b>Username</b>		<b>Password</b>	
Web address:			

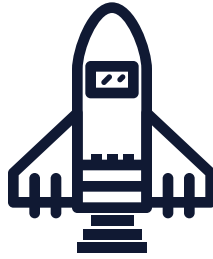

# WE HAVE LIFT OFF!



This Guide was created by Arizona GEAR UP at Northern Arizona University with support from the US Department of Education. Authorization to reproduce this publication in whole or in part is granted. While permission to reprint this guide is not necessary, the work should be credited to Arizona GEAR UP with the citation, Arizona GEAR UP, Launch - A Guide for Arizona High School Seniors, Phoenix, Arizona, 2018.

Arizona GEAR UP (Gaining Early Awareness and Readiness for Undergraduate Programs) is a project of Northern Arizona University, made possible by a grant from the U.S. Department of Education. Through partnerships with school districts and others, NAU GEAR UP is significantly increasing the number of students from low-income communities who stay in school and are prepared to enter and succeed in postsecondary education. Learn more at [nau.edu/gearup](http://nau.edu/gearup).

The federal government does not endorse this Guide, nor do its contents necessarily represent the policy of the Department of Education.

Copyright © 2018 Northern Arizona University, All rights reserved.

Arizona GEAR UP | State Office | Northern Arizona University | 15451 N. 28th Ave. | Suite 216 | Phoenix, AZ 85053 | [nau.edu/gearup](http://nau.edu/gearup)

Editing assistance provided by Shannon Sowby. Guide design by 4X Studio