

Northern Arizona University



Rendering Document

The Collegiate Wind Competition

Sponsored by the Department of Energy

Submitted towards partial fulfillment of the requirements for

The Design Review Subcontest

NORTHERN
ARIZONA
UNIVERSITY



FLAGSTAFF

Table of Contents

Section 1: Engineering Drawings	3
Turbine Assembly.....	3
Blade Drawing:	4
Mold Design Drawing:.....	5
Hub Design Drawing:.....	6
Nacelle Assembly Drawing:.....	7
Yawing System Sectional View Drawing:	8
Mainframe Drawing:	9
Base Assembly Drawing:	10
Section 2: FEA Analysis	11
Mesh used for Mainframe Analysis:	11
Mainframe Von-Mises Stress Analysis:.....	12
Mainframe Deflection Analysis:.....	13
Mainframe Material Strain Analysis:	14
Base Von-Mises Stress Analysis:	15
Base Deflection Analysis:	15
Blade Force Magnitudes and Directions:.....	16
Blade Von-Mises Stresses:	17
Blade Deformation:.....	18
Hub Deformation:	19
Section 3: Flow Analysis	20
Flow Trajectories/Velocity Profile for 4m/s:.....	20
Flow Trajectories/Velocity Profiles for 17m/s:	20
Flow Trajectories/Velocity Profiles for 12m/s:	21
Velocity Contour Plot 12m/s:.....	21
Section 4: Electrical Diagrams	22
PCB Diagram:	22

Section 1: Engineering Drawings

Turbine Assembly

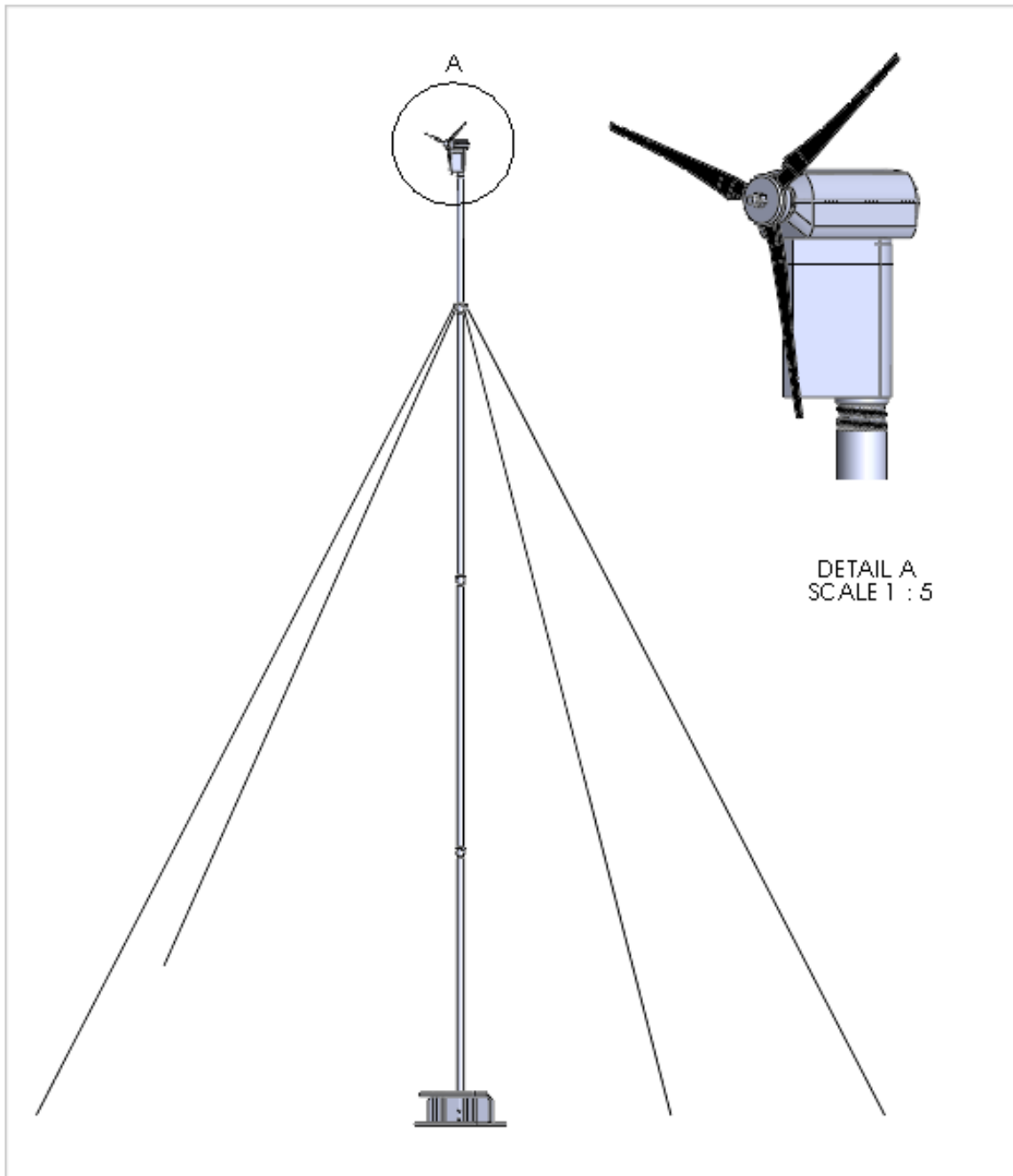

DETAIL A
SCALE 1 : 5

PROPRIETARY AND CONFIDENTIAL INFORMATION CONTAINED IN THIS DRAWING IS THE SOLE PROPERTY OF NORTHERN ARIZONA UNIVERSITY. ANY REPRODUCTION IN PART OR AS A WHOLE WITHOUT THE WRITTEN PERMISSION OF NORTHERN ARIZONA UNIVERSITY IS PROHIBITED.		DIMENSIONS ARE IN INCHES TOLERANCES: FRACTIONS ± .005 DECIMALS ± .001 HOLE DIA. ± .001 HOLE DIA. ± .001	DRAWN ENGINEER MECHANICAL ELECTRICAL	NAME DATE	DOE WIND COMPETITION NORTHERN ARIZONA UNIVERSITY
	PART ASSY USED ON	NAME DO NOT SCALE DRAWING	D.A. EDU UNIT		Turbine Assembly
	APPROVAL				DR. D-NO. NO. A
					DRAWN BY: [] CHECKED BY: []

Blade Drawing:

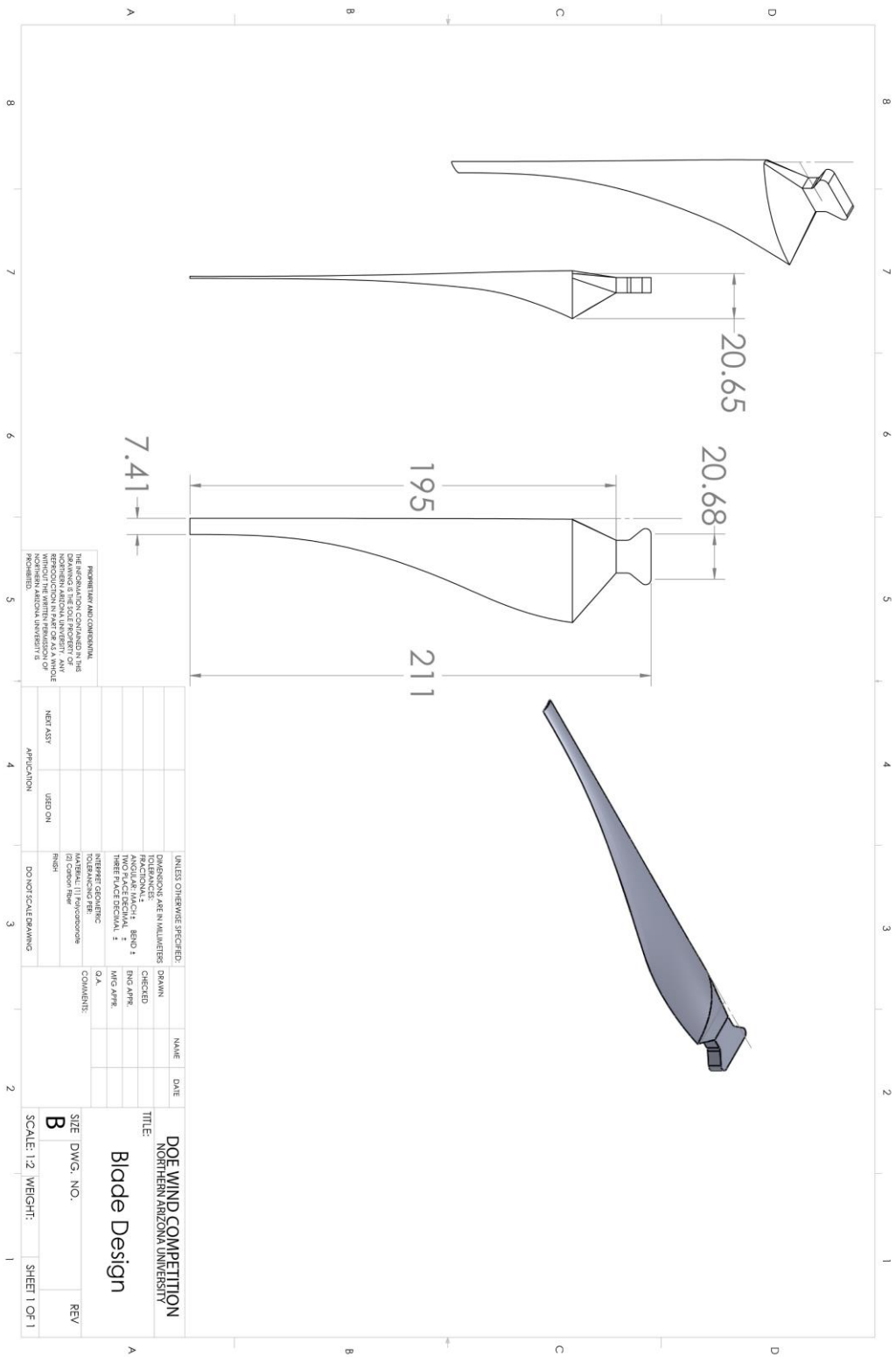

Mold Design Drawing:

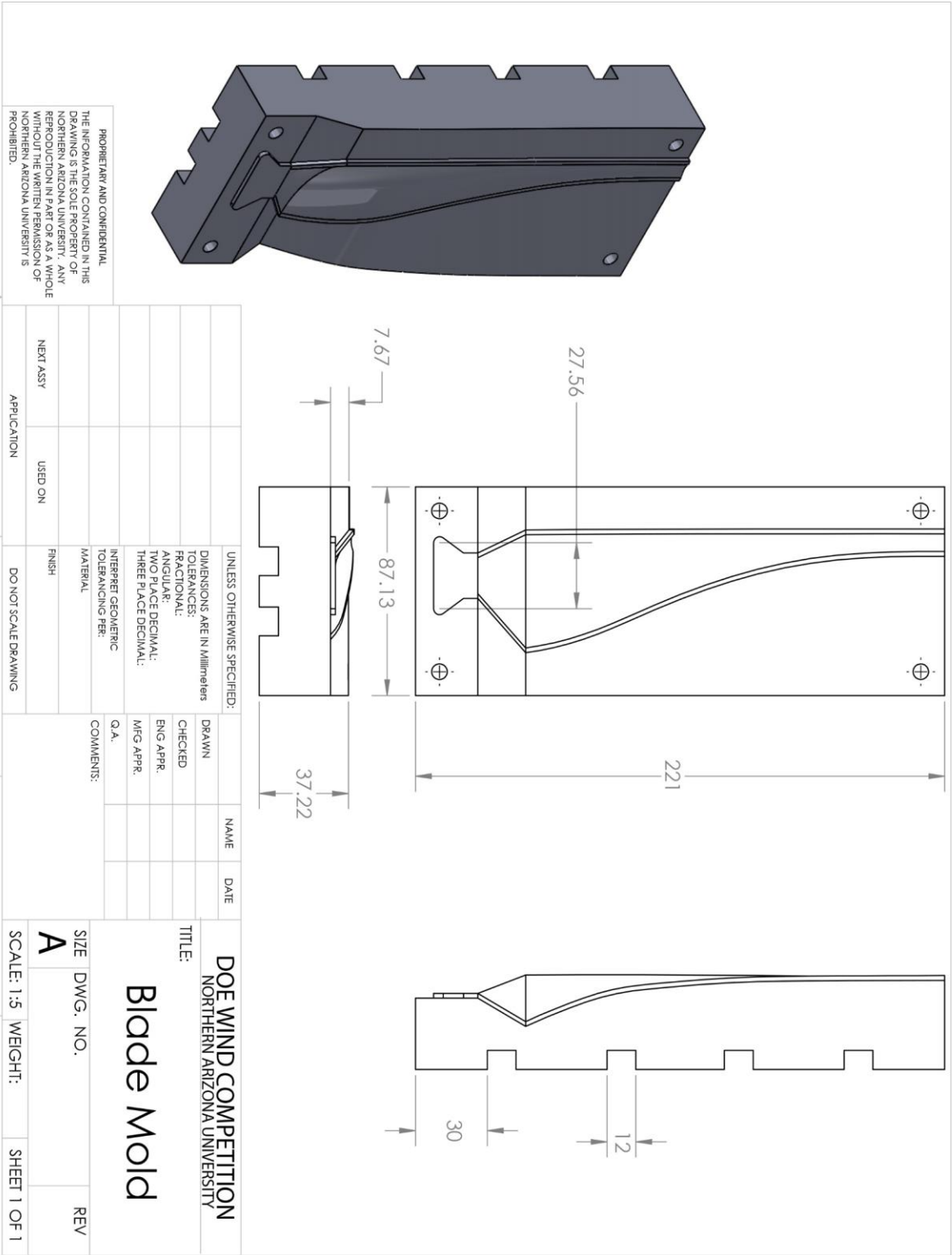

Hub Design Drawing:

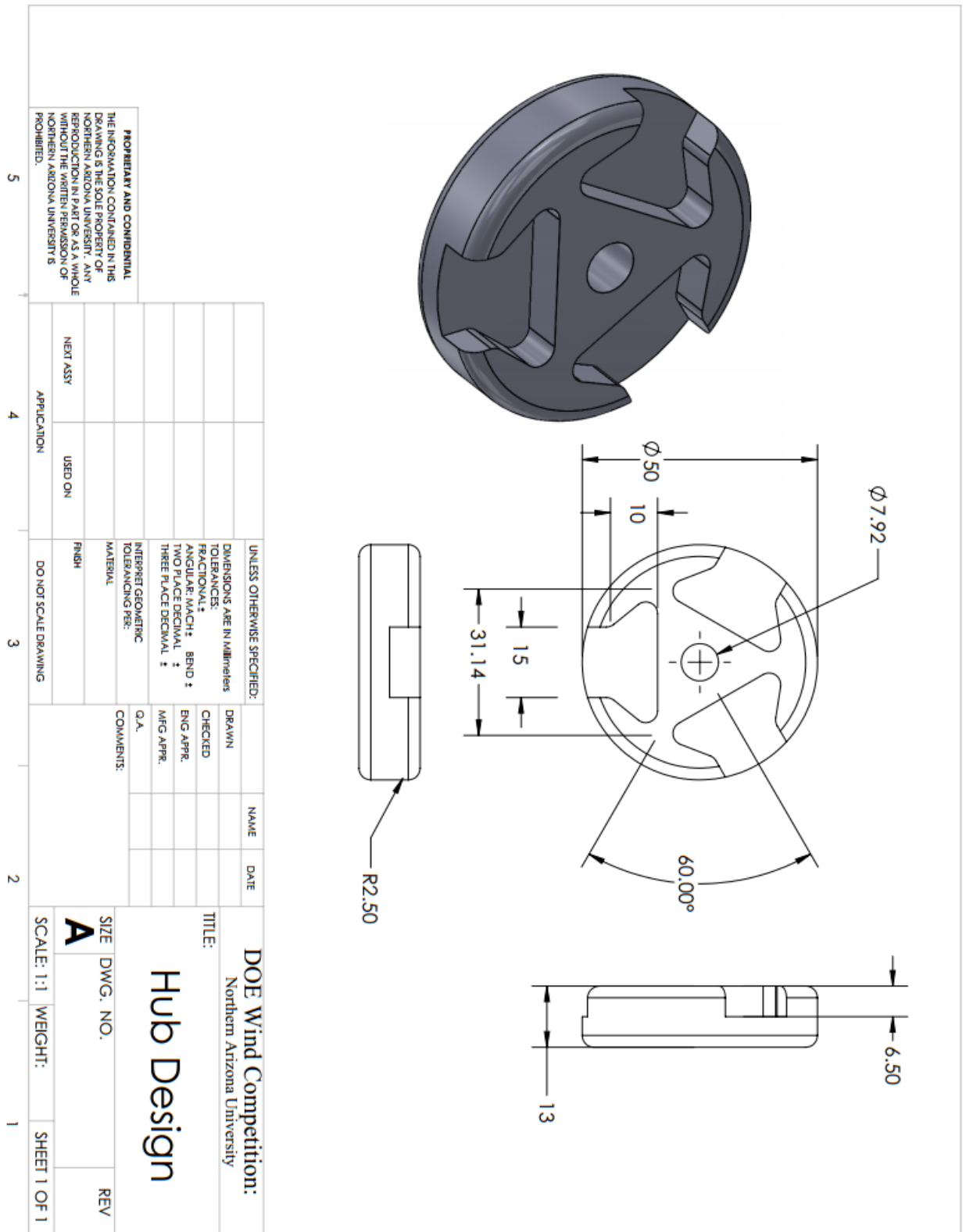

PROPRIETARY AND CONFIDENTIAL
 THE INFORMATION CONTAINED IN THIS DRAWING IS THE SOLE PROPERTY OF NORTHERN ARIZONA UNIVERSITY. ANY REPRODUCTION IN PART OR AS A WHOLE WITHOUT THE WRITTEN PERMISSION OF NORTHERN ARIZONA UNIVERSITY IS PROHIBITED.

UNLESS OTHERWISE SPECIFIED: DIMENSIONS ARE IN millimeters		DRAWN	NAME	DATE	DOE Wind Competition: Northern Arizona University Hub Design
TOLERANCES: FRACTIONAL: ±		CHECKED			
ANGULAR: MACH: ± BRND ±		ENG APPR.			
TWO PLACE DECIMAL: ±		MFG APPR.			
THREE PLACE DECIMAL: ±		Q.A.			
INTERPRET GEOMETRIC TOLERANCING PER: MATERIAL		COMMENTS:			
NEXT ASSY		USED ON	FINISH	DO NOT SCALE DRAWING	
APPLICATION					

5 4 3 2 1

SCALE: 1:1 WEIGHT: SHEET 1 OF 1

SIZE DWG. NO. REV

Nacelle Assembly Drawing:

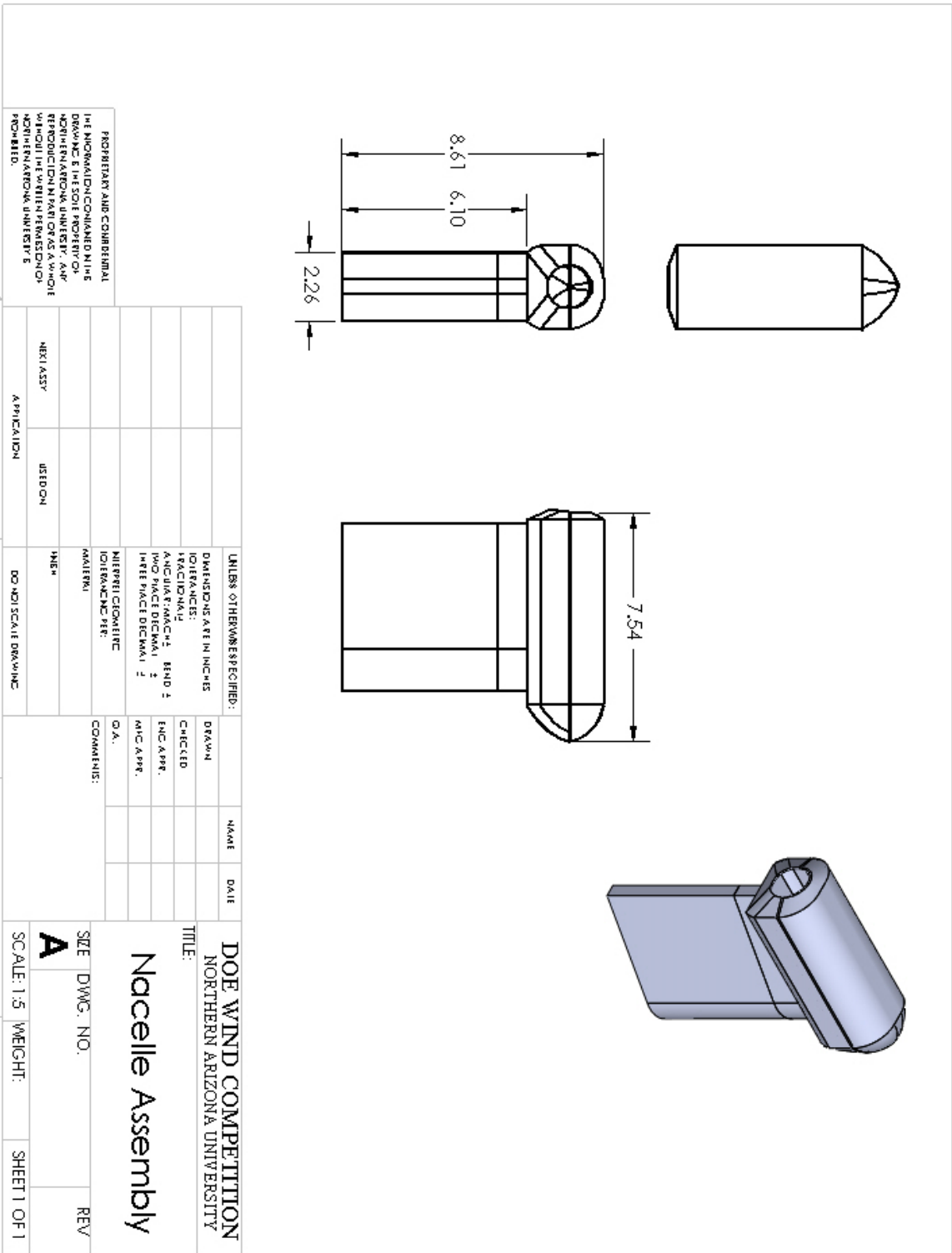

Yawing System Sectional View Drawing:

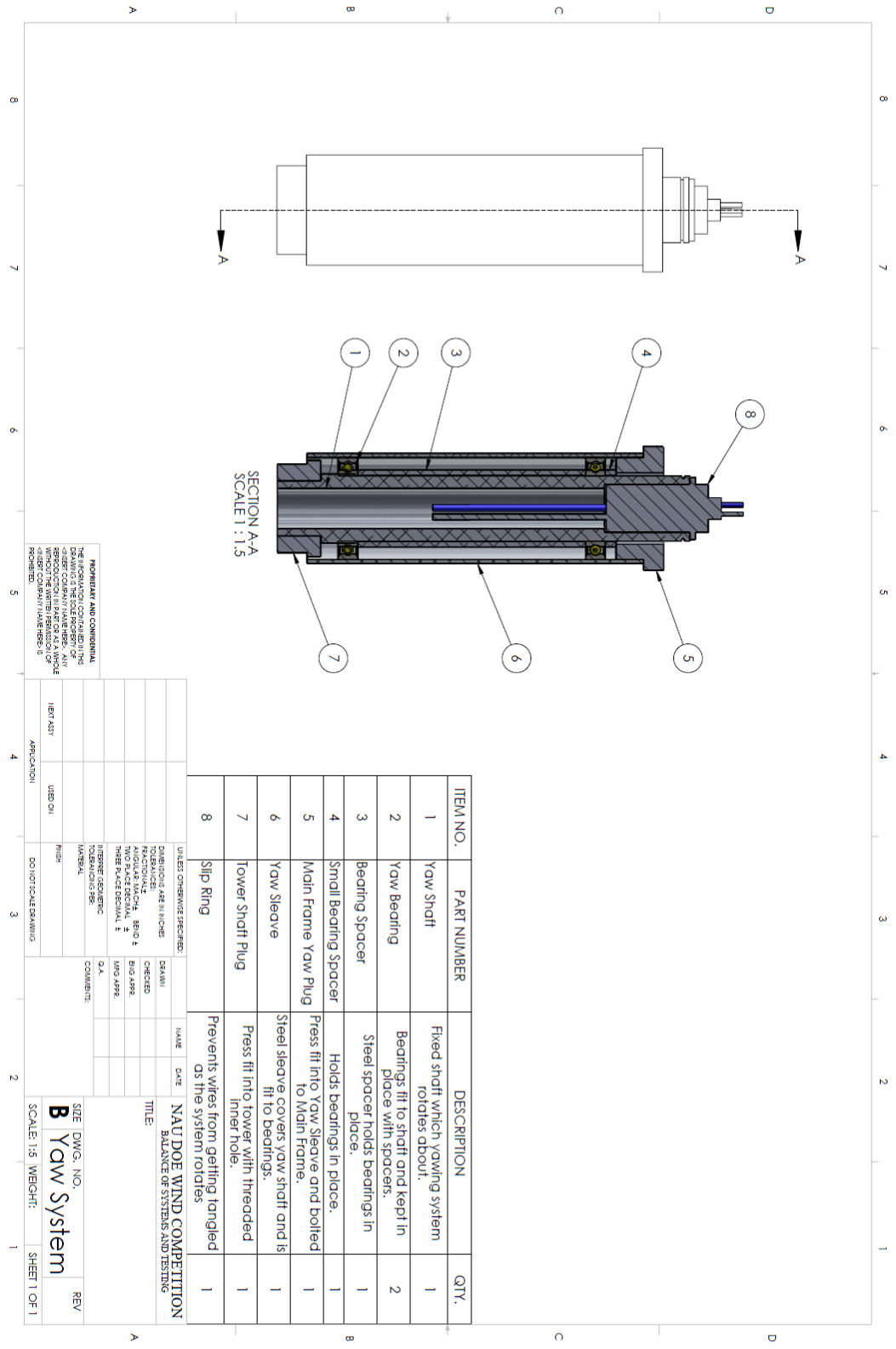

Mainframe Drawing:

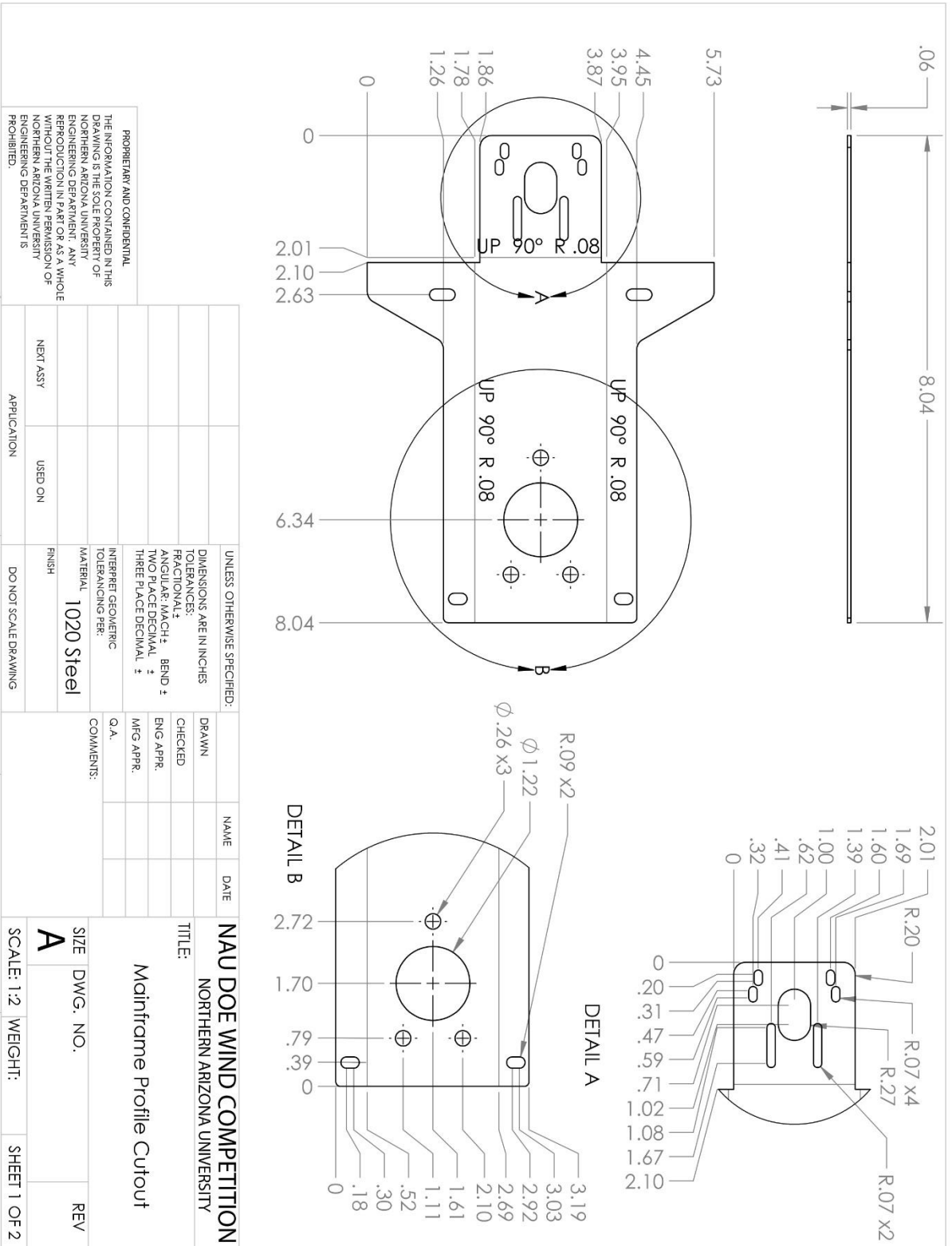

Base Assembly Drawing:

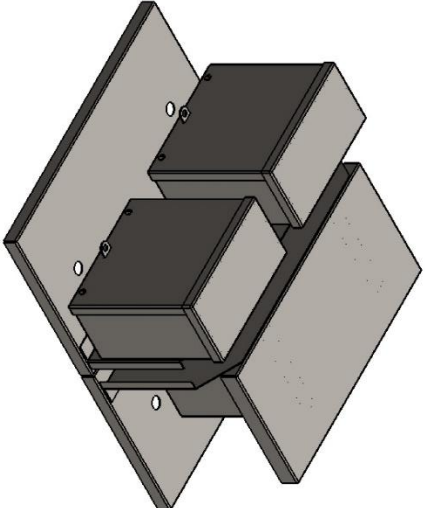
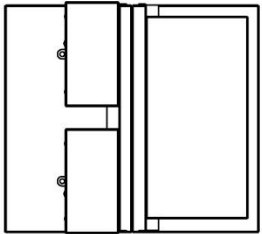
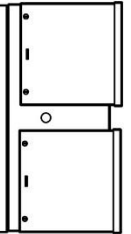
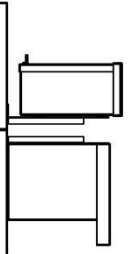





UNLESS OTHERWISE SPECIFIED: DIMENSIONS ARE IN INCHES TOLERANCES: FRACTIONAL: ± ANGULAR: MACH ± BEND ± TWO PLACE DECIMAL: ± THREE PLACE DECIMAL: ± INTERPRET GEOMETRIC TOLERANCING PER: MATERIAL FINISH		DRAWN	NAME	DATE	DOE WIND COMPETITION NORTHERN ARIZONA UNIVERSITY TITLE: Base Assembly w/ Electrical Enclosure SIZE DWG. NO. REV A	
DO NOT SCALE DRAWING	USED ON	CHECKED			SCALE: 1:12 WEIGHT:	SHEET 1 OF 1
APPLICATION	NEXT ASSY	MFG APPR.				
		Q. A.				
		COMMENTS:				

PROPRIETARY AND CONFIDENTIAL
 THE INFORMATION CONTAINED IN THIS
 DRAWING IS THE SOLE PROPERTY OF
 NORTHERN ARIZONA UNIVERSITY
 ENGINEERING DEPARTMENT. ANY
 REPRODUCTION IN PART OR AS A WHOLE
 WITHOUT THE WRITTEN PERMISSION OF
 NORTHERN ARIZONA UNIVERSITY
 ENGINEERING DEPARTMENT IS
 PROHIBITED.

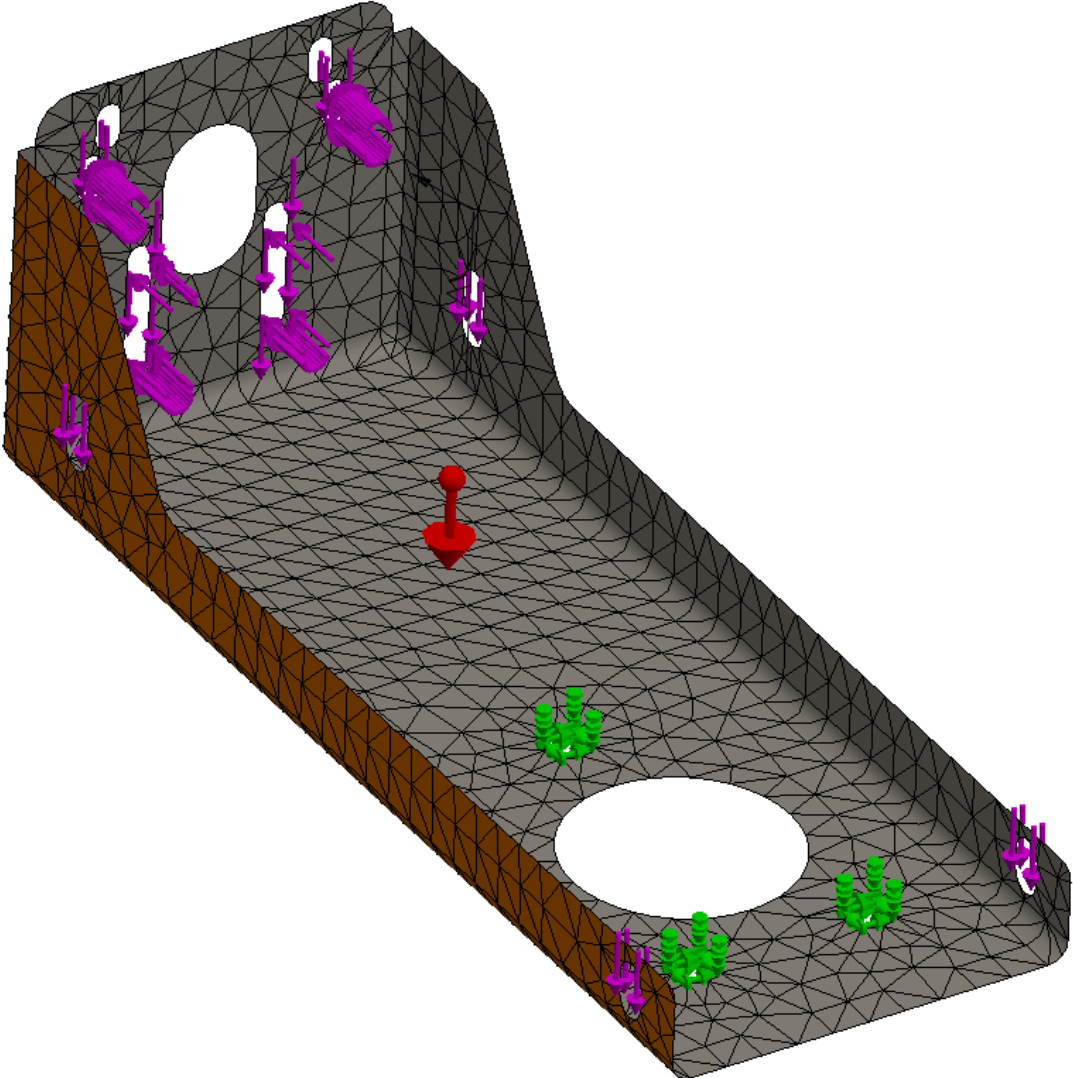
Section 2: FEA Analysis

Mesh used for Mainframe Analysis:



Mainframe Von-Mises Stress Analysis:

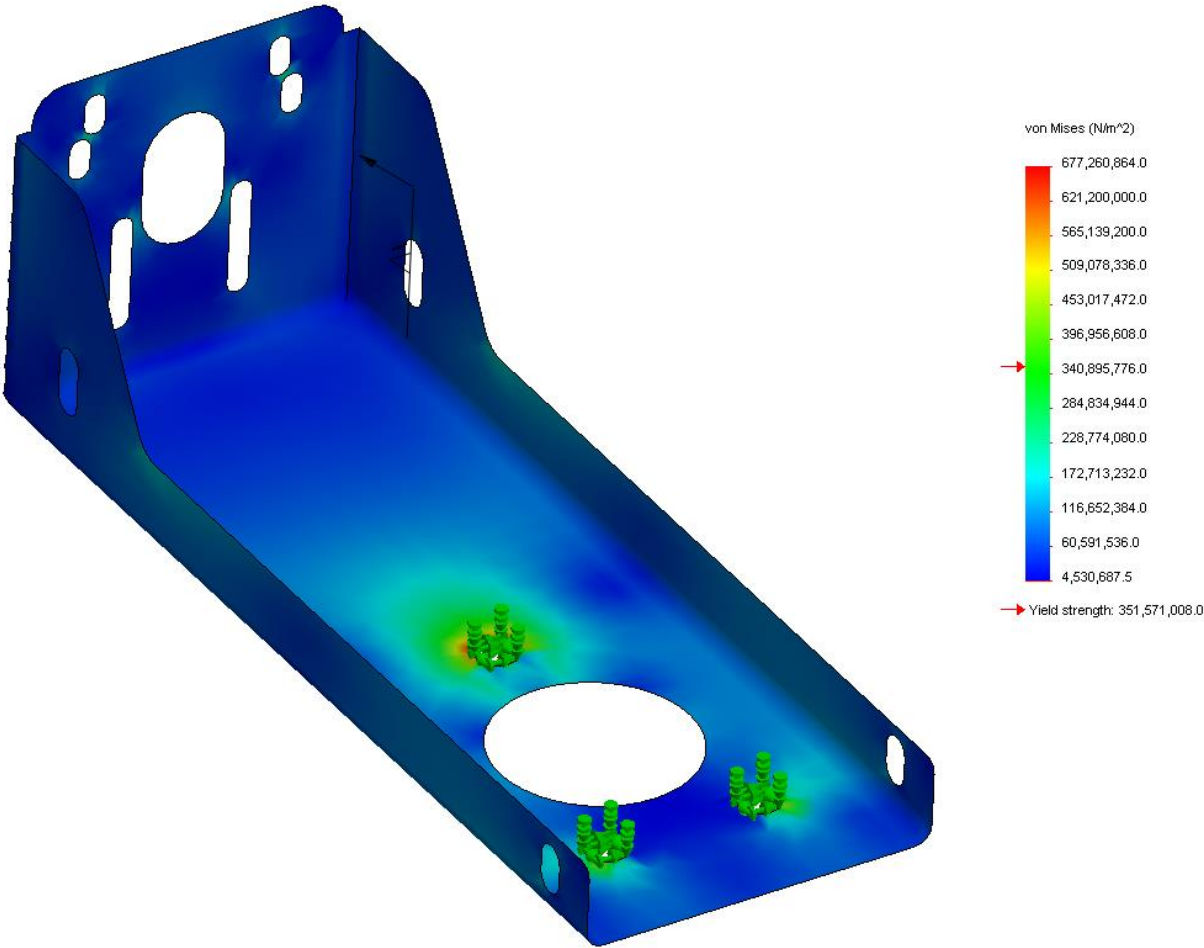

Mainframe Deflection Analysis:

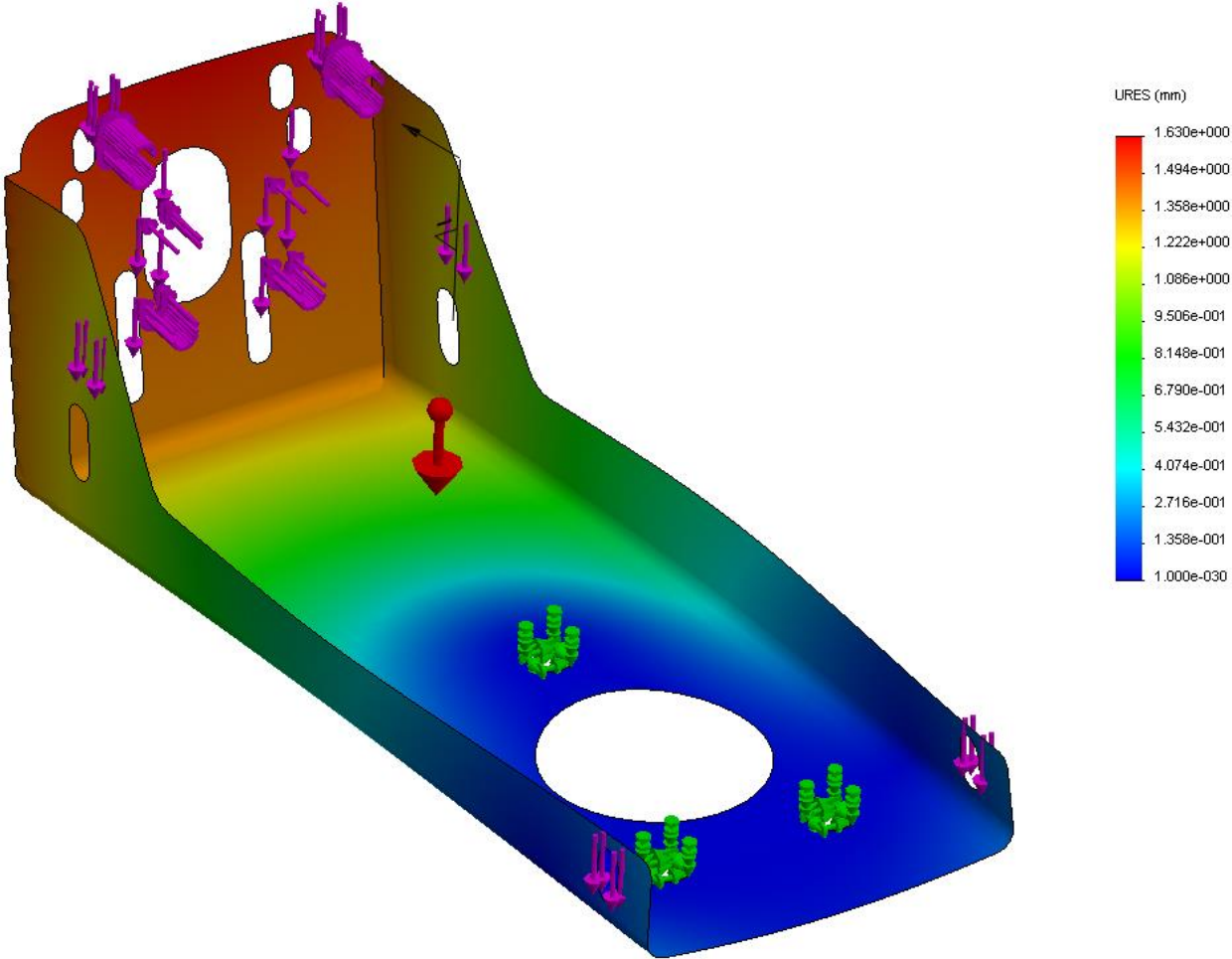

Mainframe Material Strain Analysis:

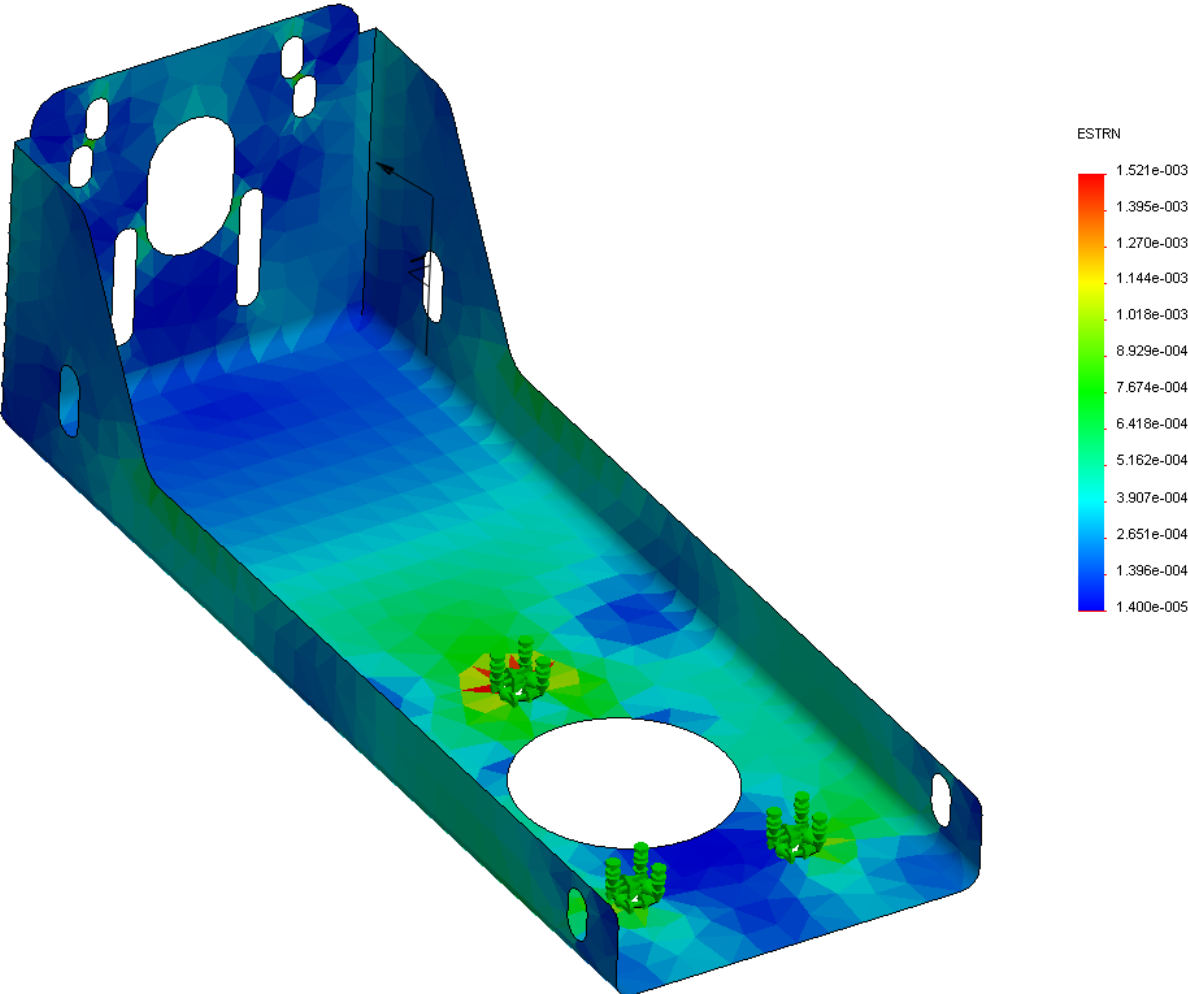

Base Von-Mises Stress Analysis:

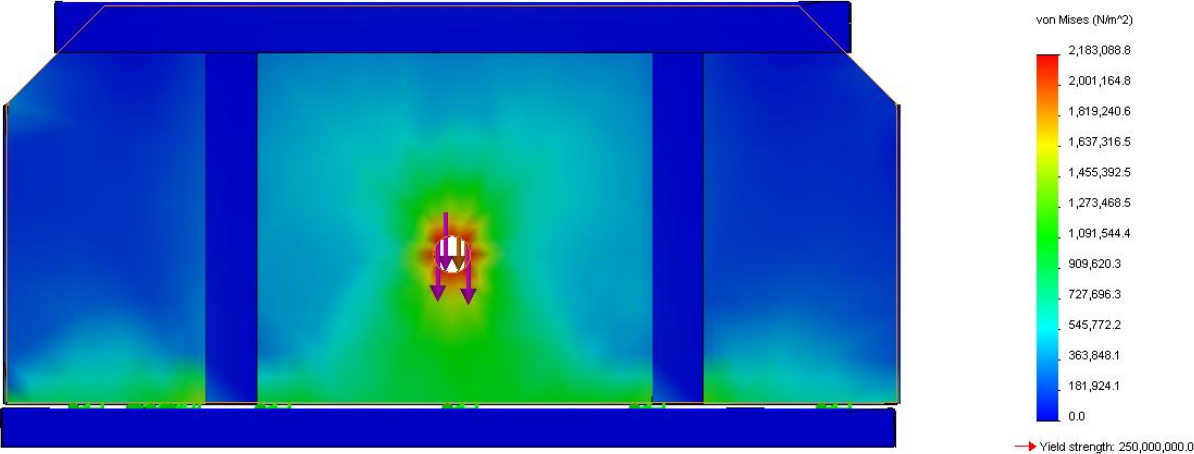

Base Deflection Analysis:

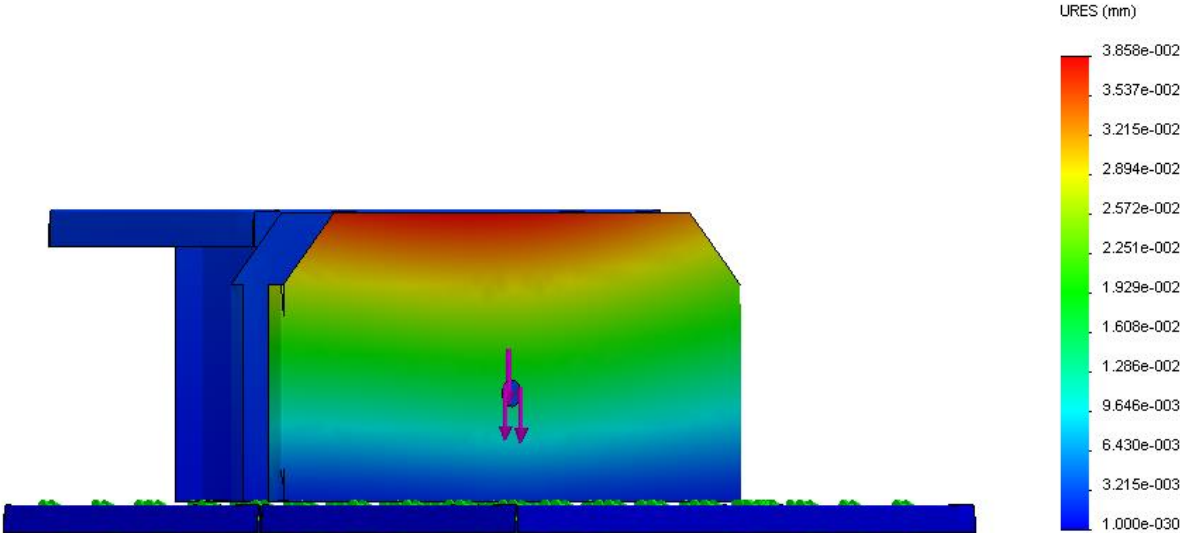

Blade Force Magnitudes and Directions:

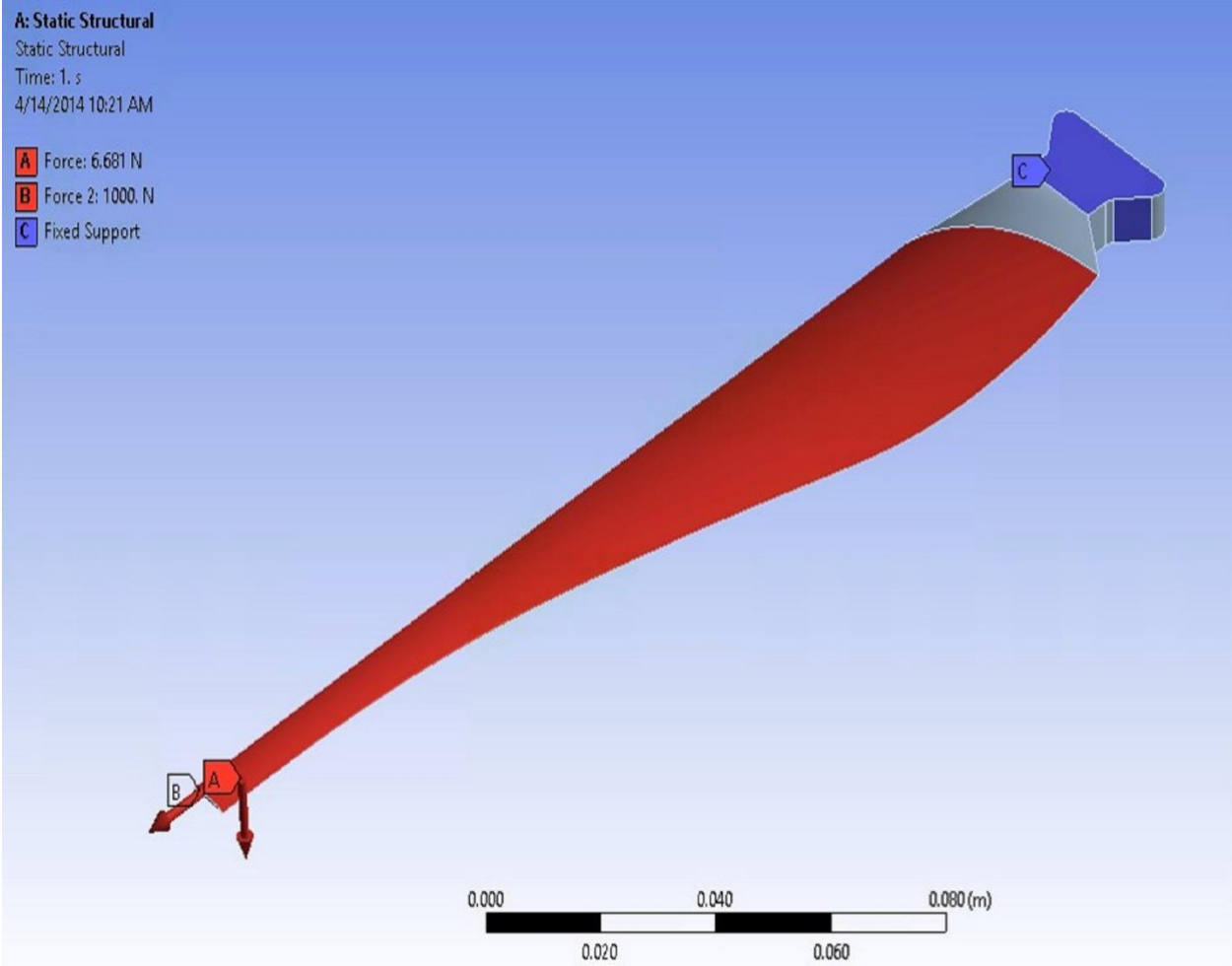

Blade Von-Mises Stresses:

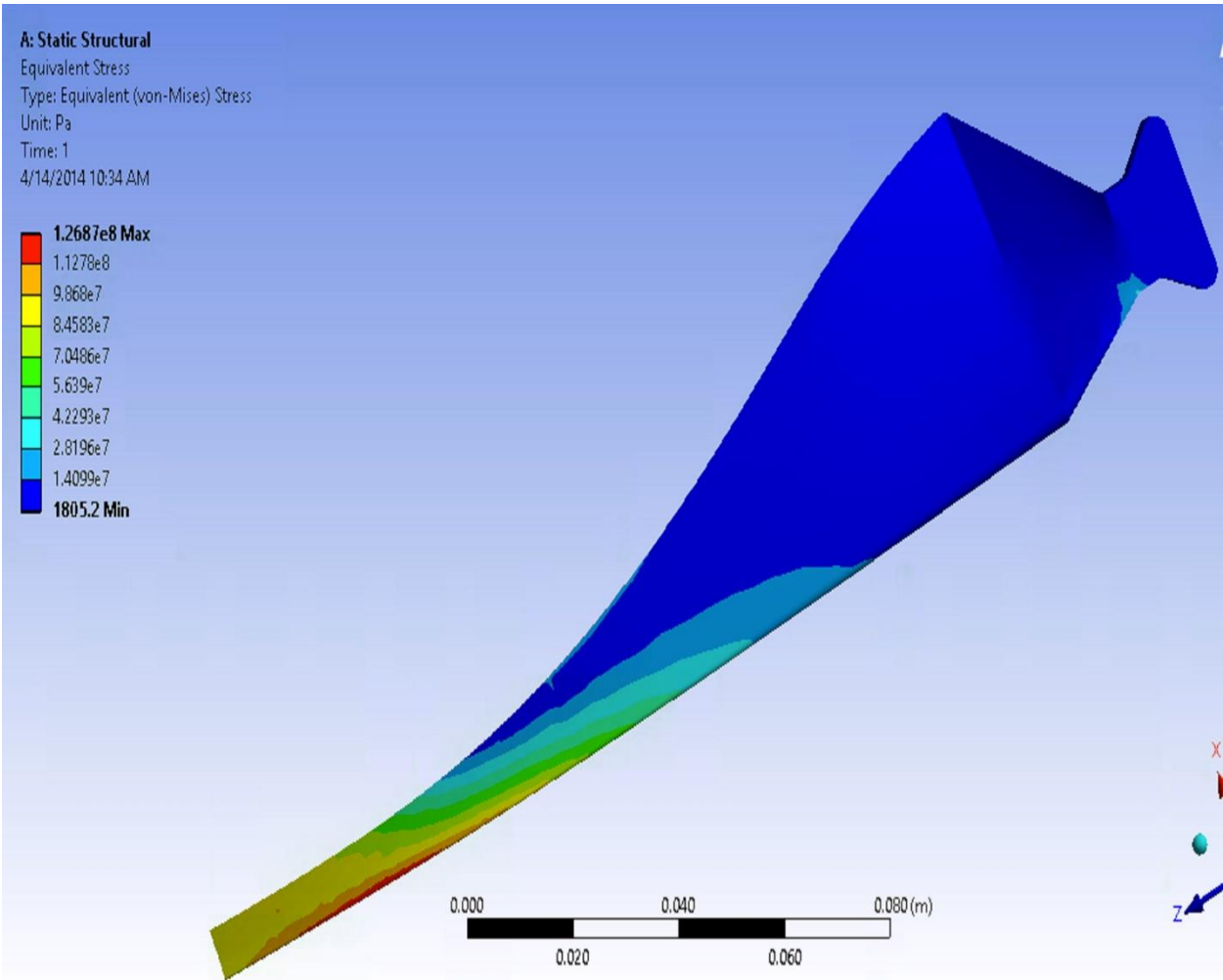

Blade Deformation:

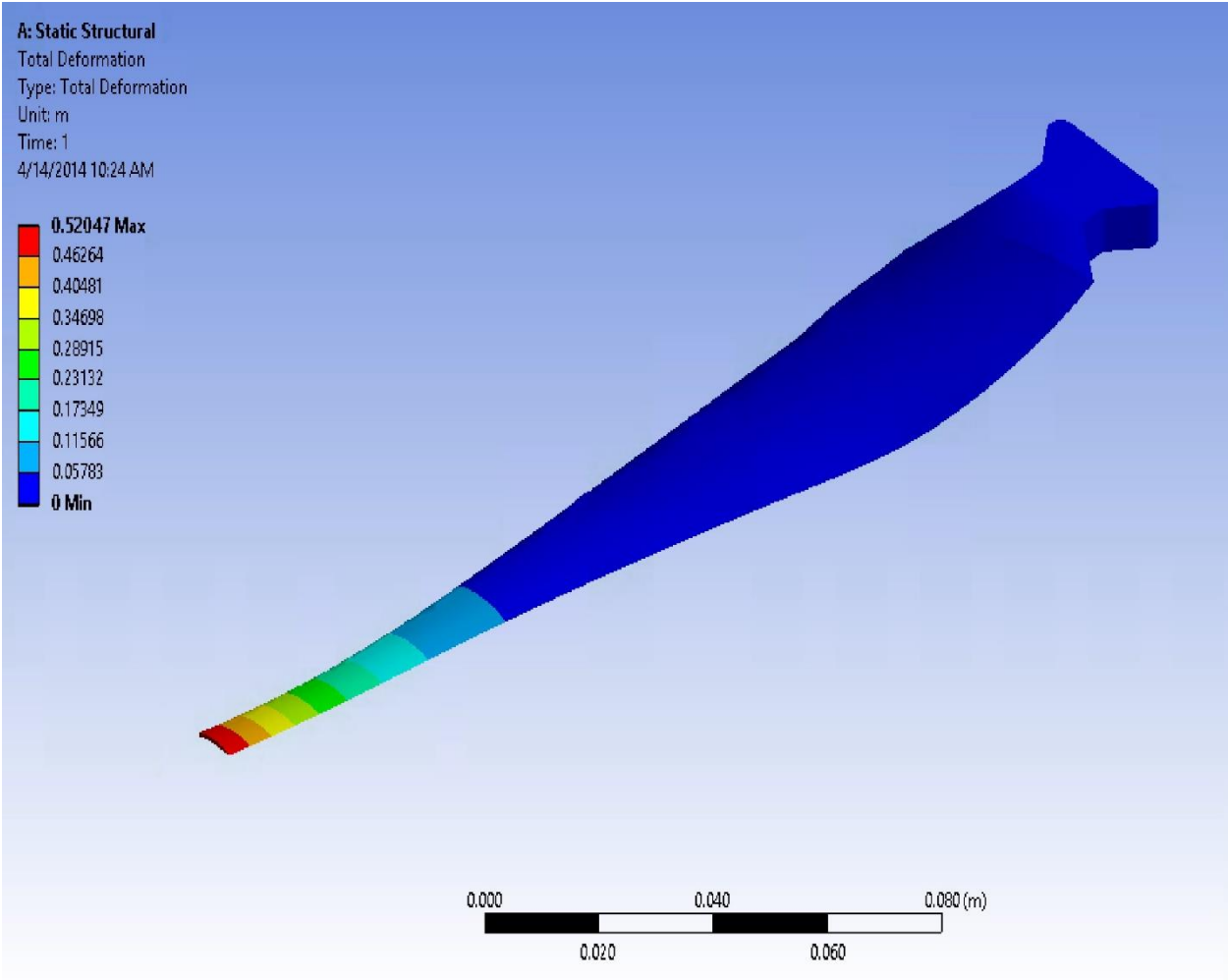

Hub Deformation:

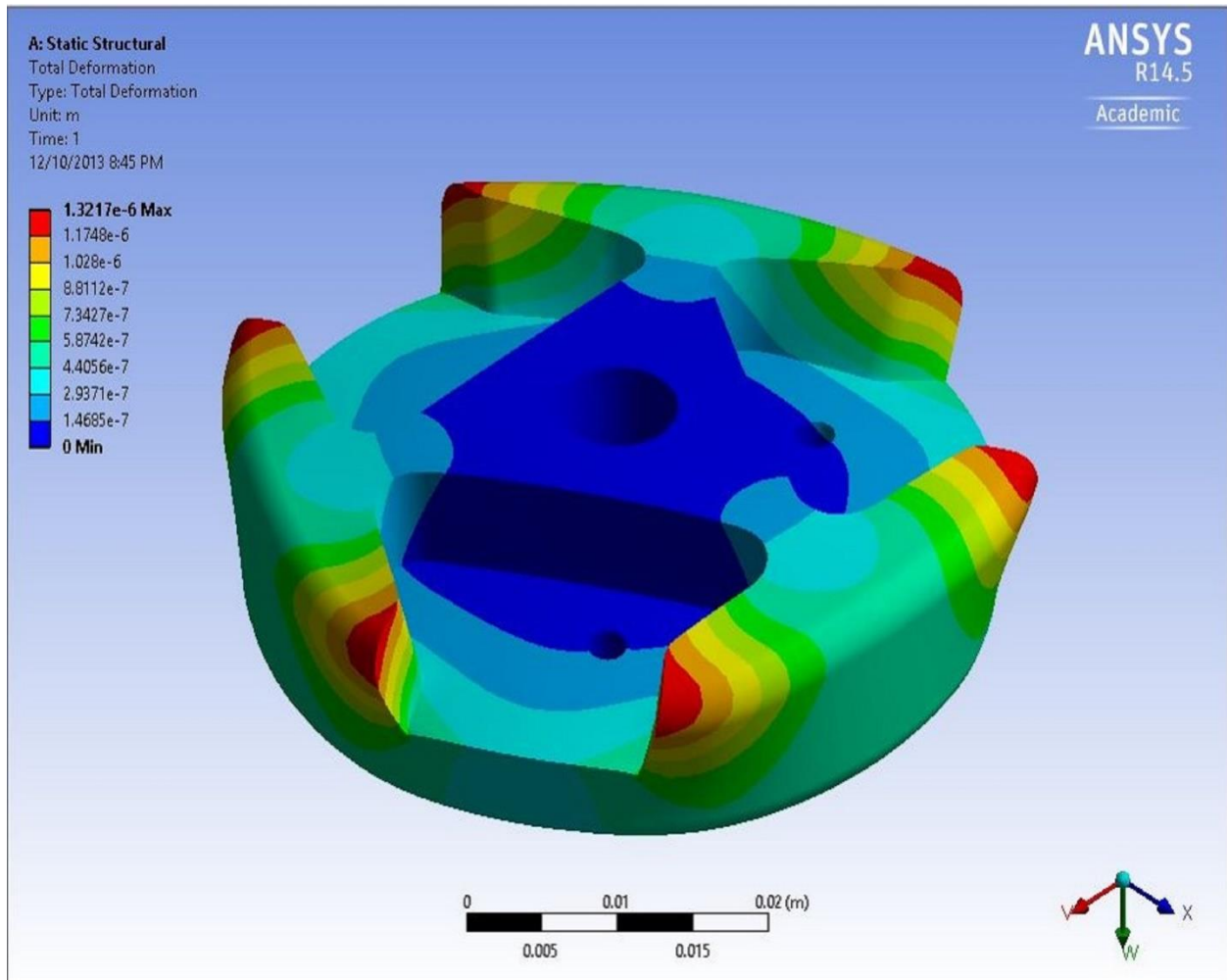

Section 3: Flow Analysis

Flow Trajectories/Velocity Profile for 4m/s:

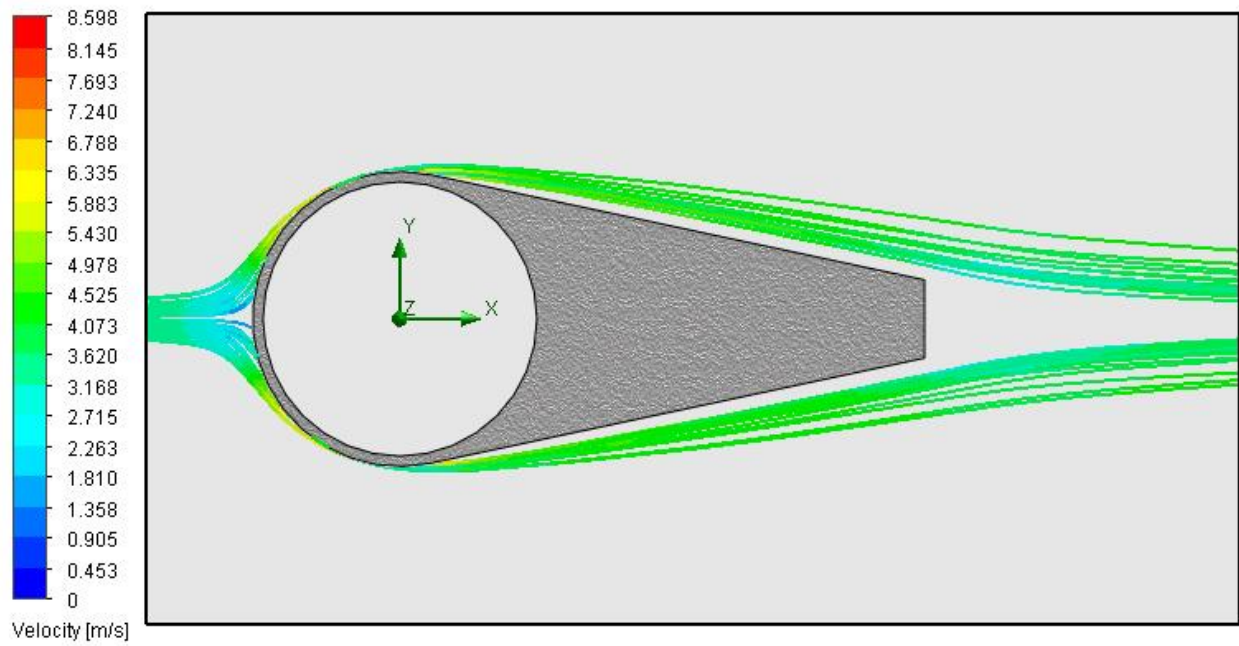

Flow Trajectories/Velocity Profiles for 17m/s:

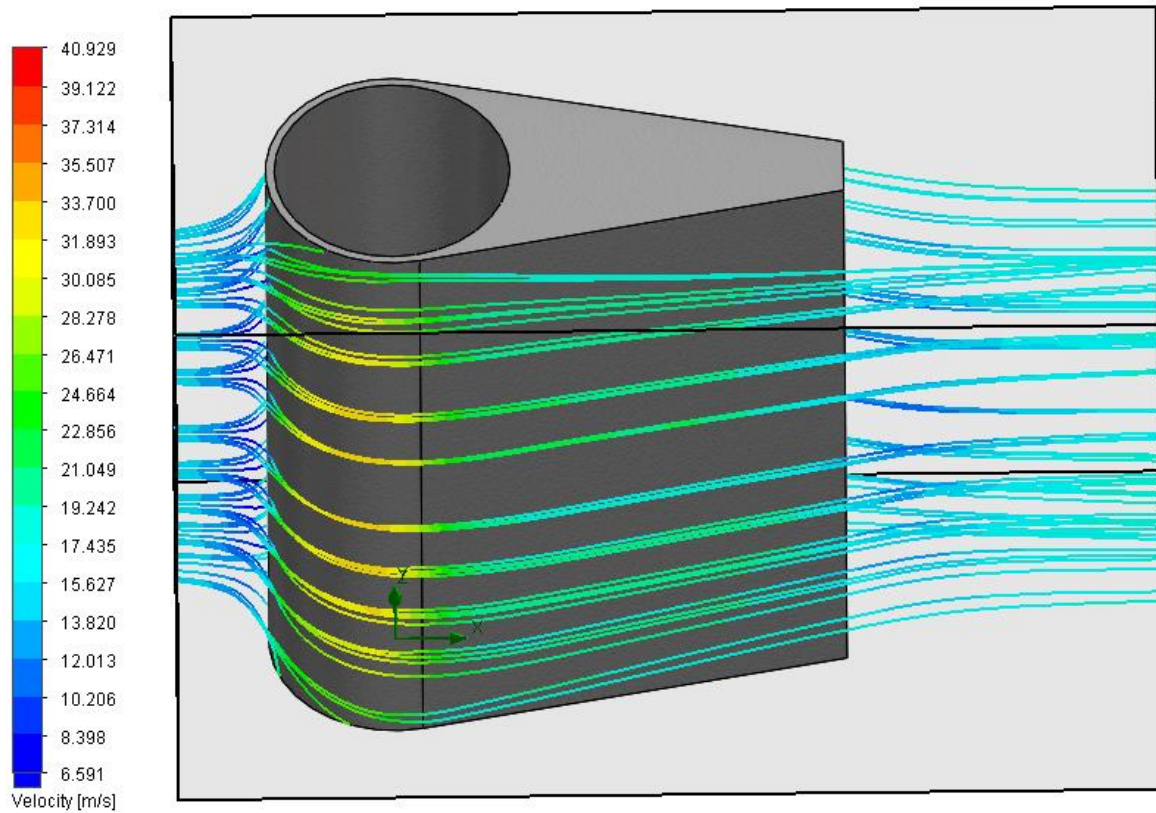

Flow Trajectories/Velocity Profiles for 12m/s:

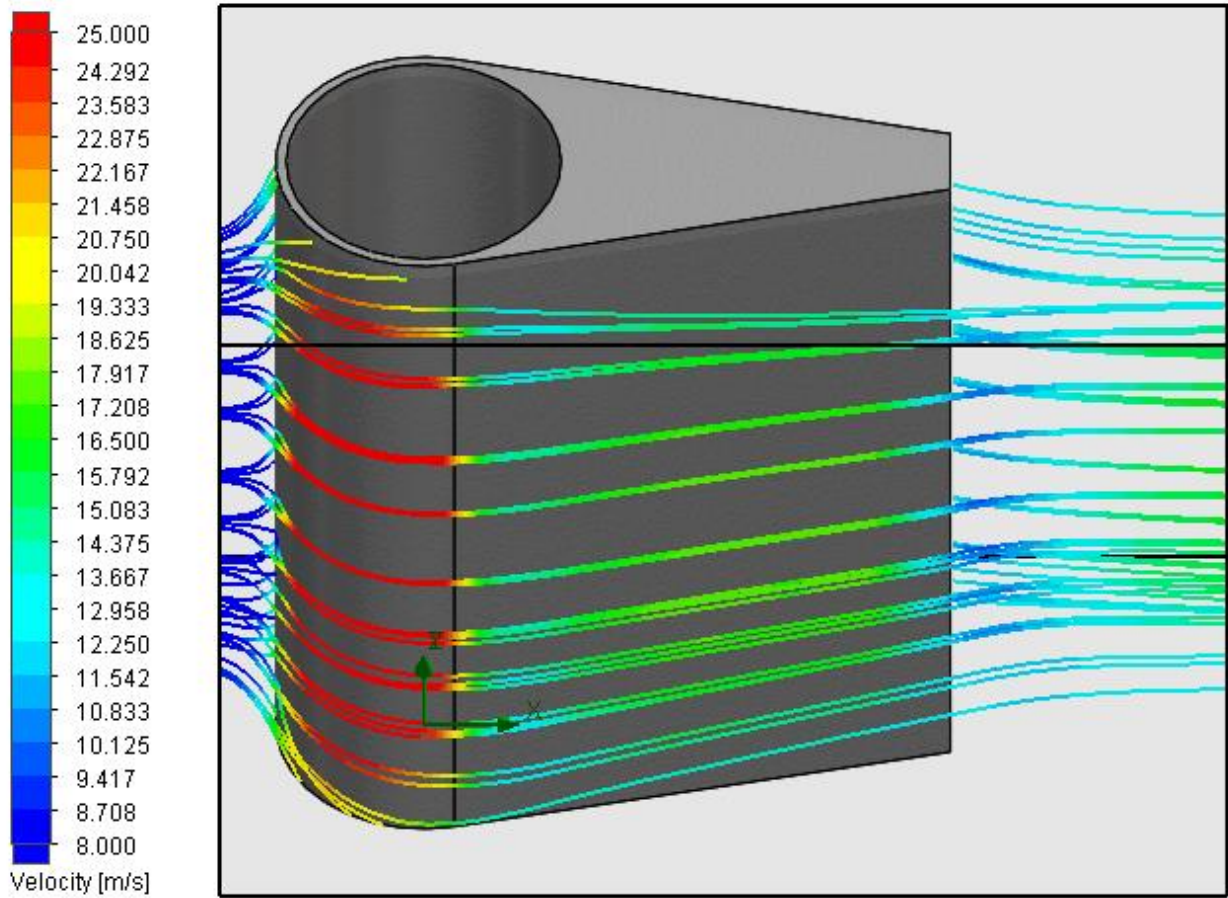

Velocity Contour Plot 12m/s:

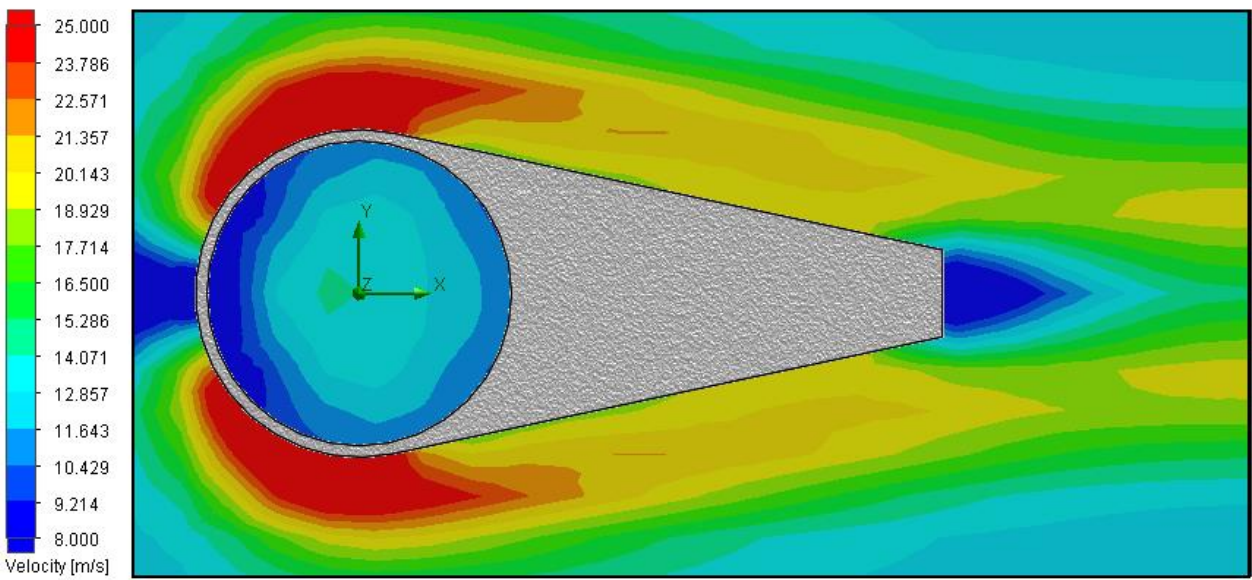

Section 4: Electrical Diagrams

PCB Diagram:

