

**Fieldhouse HVAC Replacement
NAU Project #09.300.251
Hard Bid Procurement for Construction Services
May 7, 2026**

ADDENDUM #3

PART 1 – GENERAL

- A. Date of Issue: May 7, 2026.
- B. The following Addendum shall be incorporated in the Contract Documents of the above-named job, and all requirements herein are fully a part of the Contract Documents as if included therein.
- C. Offerors shall acknowledge receipt of all Addenda in their Response to the Notice of Bid, on *Form of Bid (FS#1)*. Failure to do so may subject the Offeror to disqualification.

PART 2 – CLARIFICATIONS

- 1. To capture additional information related to Building Commissioning requirements, Sequence of Operations and other design changes, the Design Professional has issued the following:
 - a. Sheet G0.01 – Updated Sheet Index and added Building Commissioning Requirements;
 - b. Sheet M1.00 – Updated this drawing to re-route the condensate to alternate mop sink to reduce total condensate length and added clarifier notes.
 - c. Sheet M3.00 – Updated this sheet to include revised ventilation calculations and added notes to clarify outside air requirements.
 - d. Sheet M3.01 – Revised this drawing to provide a new Sequence of Operations to clarify the control scheme of the unit. Added a general note to provide controls meetings with NAU.
 - e. M3.02 – Revised this drawing to provide a new Sequence of Operations to clarify the control scheme of the unit. Added a new duct mounted CO2 sensor and a duct mounted low-limit temperature switch to HV-3 at the request of NAU. Added general note to provide controls meetings with NAU.
- 2. Because of the additional information provided above and on the revised drawings, we have removed the \$15,000 Allowance for controls work and ask Bidders to include these costs within their base bid. The Form of Bid has been revised back to the FS#1 included in Addendum #1 and is included with this Addendum.

3. Bidders shall note that the project schedule has been modified. The new schedule of important dates are shown below.

Deadline for Inquiries:	May 11, 2026, at 12:00 PM
Bids Due:	May 14, 2026, at 11:00 AM
Construction Start:	July 6, 2026
Substantial Completion:	January 29, 2027
Final Completion:	March 26, 2027

PART 3 – ADDENDUM

1. **DELETE** PROJECT SCHEDULE (page 1)
Construction Start: July 6, 2026
Substantial Completion: September 25, 2026
Final Completion: December 4, 2026

ADD PROJECT SCHEDULE (page 1)
Construction Start: July 6, 2026
Substantial Completion: January 29, 2027
Final Completion: March 26, 2027
2. **DELETE** Form of Bid (FS#1)

ADD Form of Bid (FS#1) included with this addendum.
3. **DELETE** Sheet G0.01

ADD Sheet G0.01 stamped with date 05-06-26 and included with this addendum
4. **DELETE** Sheet M1.00

ADD Sheet M1.00 stamped with date 05-06-26 and included with this addendum
5. **DELETE** Sheet M3.00

ADD Sheet M3.00 stamped with date 05-06-26 and included with this addendum
6. **DELETE** Sheet M3.01

ADD Sheet M3.01 stamped with date 05-06-26 and included with this addendum
7. **DELETE** Sheet M3.02

ADD Sheet M3.02 stamped with date 05-06-26 and included with this addendum

END OF ADDENDUM #3

FORM OF BID (FS#1)

Fieldhouse HVAC Replacement

NAU PROJECT NO. 09.300.251

The undersigned hereby proposes, and agrees to furnish all labor, material, transportation, supervision and services necessary to complete all work as called for in the plans and specifications, and that the lump sum bid includes all applicable costs of bonds, insurance, permits and fees, and sales tax, or any applicable taxes. **The Owner's selection will be made on a Bid (pre-tax) price per ABOR policy 3-803 A 7. The contract will be issued for the lump sum amount, inclusive of the tax.**

We acknowledge the following addenda and have included their provisions in this proposal.

Addendum No. _____ Dated _____

Addendum No. _____ Dated _____

Addendum No. _____ Dated _____

Addendum No. _____ Dated _____

BASE BID: The undersigned proposes to complete all work as required per the Specifications, for a Lump Sum of (noted below in words and numbers):

Bid (pre-tax): _____ Dollars
(\$ _____).

Taxes: _____ Dollars
(\$ _____).

Cumulative Bid: _____ Dollars
(\$ _____).

Enclosed herewith is a cashier's check or Bid Bond (NAU form FS#9) made payable to the Owner in the amount of \$ _____, which is not less than 10% of the amount of the total bid proposal, as a guarantee that the undersigned will furnish required Performance Bond and Labor and Material Bond, and enter into contract, on basis of above proposal.

Undersigned further agrees that said check (or Bid Bond) shall be forfeited as Liquidated Damages (no penalty) if undersigned fails to enter into contract after requested to do so by Owner.

Bids shown above are valid for a period of 60 days after the date of opening bids, and may be withdrawn following that date if no contract has been awarded.

The undersigned understands that the Owner reserves the right to reject any or all bids, or to waive any informality in receipt of the above Proposal. **Owner reserves the right to award by Base Bid alone, by the sum of Base Bid and any combination of Additive Alternate Amounts, or as the sum of the Base Bid and all the Additive Alternate Amounts, whichever is deemed most advantageous to Owner.**

It is hereby understood and mutually agreed by and between the Contractor and the Owner that the date of beginning, rate of progress, and time of completion of the Work as set forth in the contract documents are of the essence of the contract. The amount of **\$100.00 per calendar day** will be assessed against the contract for work not completed at the Substantial Completion date. Said amounts shall accrue until such time that the Work covered under this contract is complete, not as a penalty, but as Liquidated Damages.

In addition, it is mutually agreed by and between the Contractor and the Owner, the amount of **\$50.00 per calendar day for each phase** will be assessed against the contract for work not completed at the Final Completion date. Said amounts shall accrue until such time that the Work covered under this contract is complete, not as a penalty, but as Liquidated Damages.

The Proposer hereby certifies that he/she is the holder of a valid Contractor's License in accordance with Arizona State Law and that such license classification allows the Contractor to perform the type of construction identified by these Bid Documents. The proposer also certifies that he/she holds all of the required certifications and licenses outlined in the bidding documents and shall provide proof of all certifications, licenses and warranties within 5 days of Owner notification to the apparent low bidder with the Intent to Award.

If corporation,

Company/Corporation

Seal

Signature

Date

Arizona License Class and Number

ABBREVIATIONS

AB	ANCHOR BOLT	HWY	HIGHWAY
ABC	AGGREGATE BASE COURSE	ICC	INTERNATIONAL CONSTRUCTION COUNCIL
ACT	ACOUSTICAL CEILING TILE	ID	INSIDE DIMENSION
AD	AREA DRAIN	INCL	INCLUDING
ADDL	ADDITIONAL	INFO	INFORMATION
ADJ	ADJUSTABLE	INSUL	INSULATION
A.F.F.	ABOVE FINISHED FLOOR	JT	JOINT
AL	ALUMINUM	KDHM	KNOCK DOWN HOLLOW METAL
ANOD	ANODIZED	LAM	LAMINATE
ARCH	ARCHITECTURAL	LH	LEFT HAND
BD	BOARD	LIN	LINEAR
BETWN	BETWEEN	LL	LOWER LEVEL
BLDG	BUILDING	LP	LOW POINT
BLK	BLOCK, BLOCKING	LTWT	LIGHT WEIGHT
BM	BENCH MARK	MAX	MAXIMUM
BOT	BOTTOM	MC	MINERAL CORE
BRG	BEARING	MECH	MECHANICAL
BS	BOTH SIDES	MEJ	MASONRY EXPANSION
BSMT	BASEMENT	MFR	MANUFACTURER
BUR	BUILT-UP ROOFING	MH	MANHOLE
CAB	CABINET	MIN	MINIMUM
CPT	CARPET	MISC	MISCELLANEOUS
CB	CATCH BASIN	MO	MASONRY OPENING
CFMF	COLD FORMED METAL FRAMING	MTD	MOUNTED
		NIC	NOT IN CONTRACT
CJ	CONTROL JOINT	NLWT	NORMAL WEIGHT
CL	CENTER LINE	NO	NUMBER
CLG	CEILING	NOB	NOMINAL
CLR	CLEAR	NS	NEAR SIDE
CMT	CERAMIC MOSAIC TILE	NTS	NOT TO SCALE
CMU	CONCRETE MASONRY UNIT	O.C.	ON CENTER
CO	CLEANOUT	OD	OUTSIDE DIAMETER
COL	COLUMN	OPNG	OPENING
CONC	CONCRETE	OPP	OPPOSITE
CONT	CONTINUOUS	OH	OPPOSITE HAND
CP	CEMENT PLASTER	ORD	OVERFLOW ROOF DRAIN
CT	CERAMIC TILE	PR	PAIR
CJ	CUBIC	PL	PLATE
DBL	DOUBLE	PLAM	PLASTIC LAMINATE
DEMO	DEMOLITION	PLAS	PLASTER
DET	DETAIL	PLYWD	PLYWOOD
D.G.	DECOMPOSED GRANITE	PT	PAINT
DIA	DIAMETER	QT	QUARRY TILE
DIM	DIMENSION	R	RADIUS
DF	DRINKING FOUNTAIN	RCP	REFLECTED CEILING PLAN
DN	DOWN	REINF	REINFORCE, REINFORCING
DS	DOWNSPOUT	REF	REFERENCE
DWG	DRAWING	REQD	REQUIRED
EA	EACH	RH	RIGHT HAND
EF	EACH FACE	RD	ROOF DRAIN
EL	ELEVATION	RDL	ROOF DRAIN LEADER
ELEC	ELECTRIC	RM	ROOM
EP	EPOXY PAINT	RO	ROUGH OPENING
EQ	EQUAL	SC	SOLID CORE
EQUIP	EQUIPMENT	SCHED	SCHEDULE
EWC	ELECTRIC WATER COOLER	SD	SMOKE DETECTOR
EXIST	EXISTING	SEC	SECTION
EXP	EXPANSION	SES	SERVICE ENTRANCE
EXP JT	EXPANSION JOINT	SGT	STRUCTURAL GLAZED TILE
EW	EACH WAY	SHT	SHEET
FAAR	FIRE APPARATUS ACCESS	SIM	SIMILAR
FD	FLOOR DRAIN	SM	SHEET METAL
FDN	FOUNDATION	SOG	SLAB ON GRADE
FE	FIRE EXTINGUISHER	SP	STARTING POINT
FEC	FIRE EXTINGUISHER CABINET	SPEC	SPECIFICATIONS
		SQ	SQUARE
FHC	FIRE HOSE CABINET	SS	STAINLESS STEEL
FLR	FLOOR	STD	STANDARD
FS	FAR SIDE	STL	STEEL
FT	FEET	STRUC	STRUCTURAL
FTG	FOOTING	ST&V	STAIN & VARNISH
GA	GAUGE, GAGE	SUSP	SUSPENDED
GALV	GALVANIZED	TBS	TO BE SELECTED
GCB	GYPSSUM CEILING BOARD	T&B	TOP AND BOTTOM
GWB	GYPSSUM WALL BOARD	THK	THICK
GL	GLASS	T.O.	TOP OF
GMU	GLAZED MASONRY UNIT	TYP	TYPICAL
GST	GLAZED STRUCTURAL TILE	UNO	UNLESS NOTED OTHERWISE
GP	GYPSSUM PLASTER	UL	UNDERWRITER'S LABORATORY
GR	GRADE	VCT	VINYL COMPOSITION TILE
HC	HOLLOW CORE	VENT	VENTILATION
HDCP	HANDICAPPED	VERT	VERTICAL
HDWD	HARDWOOD	VEST	VESTIBULE
HM	HOLLOW METAL	VIF	VERIFY IN FIELD
HORZ	HORIZONTAL	VOL	VOLUME
HP	HIGH POINT	VT	VINYL TILE
HR	HOUR	W/	WITH
HT	HEIGHT	WC	WALL COVERING
HTG	HEATING	WD	WOOD
HVAC	HEATING/VENTILATION/ AIR CONDITIONING	WH	WALL HEATER
		W/O	WITHOUT
		WWF	WELDED WIRE FABRIC

SYMBOLS LEGEND

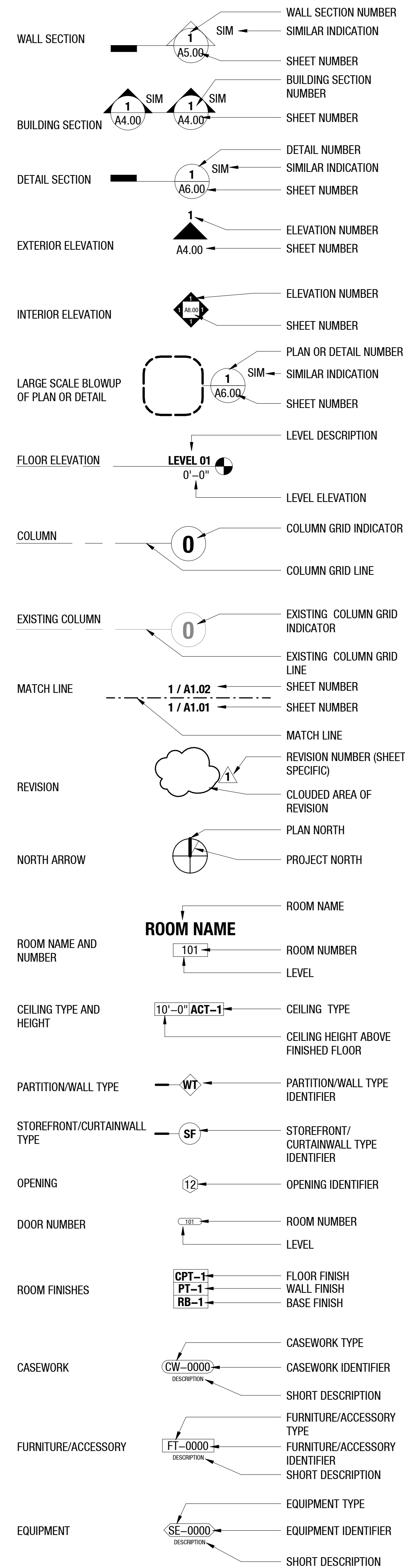

PROJECT DESCRIPTION

THE FIELDHOUSE (BUILDING 30) WILL BE RENOVATED TO SUPPORT A FUTURE MULTIPURPOSE FACILITY WITH A SEASONAL ICE RINK. THIS PROJECT'S SCOPE WILL INCLUDE MECHANICAL PLATFORMS, AND MECHANICAL UPGRADES TO THE SPACE. THIS PROJECT WILL INCLUDE SELECTIVE DEMOLITION, STRUCTURAL, MECHANICAL, ELECTRICAL.

THE DEMOLITION WORK IN THIS SCOPE CONSISTS OF SELECTIVE REMOVAL OF EXISTING MECHANICAL UNITS AND PLATFORMS.

APPLICABLE CODES

CLIMATE ZONE 5B
SEISMIC DESIGN CATEGORY B

ALL DESIGN AND CONSTRUCTION WORK SHALL BE DONE IN SUCH A MANNER THAT THE COMPLETION OF THE PROJECT IS IN COMPLIANCE WITH THE FOLLOWING CODES AND STANDARDS THE OWNER HAS ADOPTED AS CODE. WHEN REFERENCE HAS BEEN MADE TO "THIS CODE" IT SHALL MEAN ALL THE CODES LISTED BELOW. IN THE EVENT THERE IS A CONFLICT BETWEEN ANY OF THE CODES AND STANDARDS, THE MOST RESTRICTIVE CODE SHALL APPLY.

TYPE	CODE REFERENCE
EXISTING BUILDING ENERGY	2021 INTERNATIONAL EXISTING BUILDING CODE (IEBC)
PLUMBING	2021 INTERNATIONAL ENERGY CONSERVATION CODE (IECC)
MECHANICAL	2021 INTERNATIONAL PLUMBING CODE (IPC)
ELECTRICAL	2021 INTERNATIONAL MECHANICAL CODE (IMC)
FUEL GAS	2020 NATIONAL ELECTRICAL CODE (NEC / NFPA 70)
FIRE	2021 INTERNATIONAL FUEL GAS CODE (IFGC)
BUILDING	2021 INTERNATIONAL FIRE CODE (IFC)
FIRE ALARM	2021 INTERNATIONAL BUILDING CODE (IBC)
FIRE SPRINKLER	2022 NATIONAL FIRE ALARM CODE 2016 (NFPA 72)
	2022 INSTALLATION OF SPRINKLER SYSTEMS (NFPA 13)
	2025 NAU FIRE CODE
ACCESSIBILITY	2012 ARIZONA STATE FIRE CODE (FOR STATE COMPLIANCE REF.)
	2017 ACCESSIBLE & USABLE BUILDINGS AND FACILITIES (ICC/ANSI A117.1) WHERE CONFLICTS ARISE BETWEEN APPLICABLE ACCESSIBILITY REQUIREMENTS (E.G., 2021 IBC, 2010 ADA STANDARDS, ICC A117.1-2017, NAU TECHNICAL STANDARDS, OR OTHER STATE/FEDERAL REQUIREMENTS), THE MOST RESTRICTIVE PROVISIONS SHALL APPLY.
	2010 ADA STANDARDS FOR ACCESSIBLE DESIGN AS APPROVED BY THE DEPARTMENT OF JUSTICE ON JULY 26, 2010 (PUBLISHED IN THE FEDERAL REGISTER ON SEPT 15, 2010)
ELEVATOR	2022 AMERICAN SOCIETY OF MECHANICAL ENGINEERS (ASME) A17.1, SAFETY CODES FOR ELEVATORS AND ESCALATORS (UNLESS OTHERWISE REQUIRED)
	AZ ELEVATOR ACT - TITLE 23, CHAPTER 2, ARTICLE 12 OF THE ARIZONA REVISED STATUTES (ARS)
ELEVATOR SAFETY	ARIZONA ADMINISTRATIVE CODE R20-5-507 (ADOSH ELEVATOR SAFETY RULES)
	2022 AMERICAN SOCIETY OF MECHANICAL ENGINEERS (ASME) A17.1, SAFETY CODES FOR ELEVATORS AND ESCALATORS (UNLESS OTHERWISE REQUIRED)

ADDITIONAL CRITERIA

SUSTAINABILITY	AZ EXECUTIVE ORDER 2008-29 (REAFFIRMS EO 2005-05; REQUIRES ALL NEW STATE-FUNDED BUILDINGS TO ACHIEVE A MINIMUM LEED SILVER CERTIFICATION)
ASHRAE STANDARDS	2023 ASHRAE 55 (THERMAL ENVIRONMENTAL CONDITIONS FOR HUMAN OCCUPANCY)
	2019 ASHRAE 62.1 (VENTILATION FOR ACCEPTABLE INDOOR AIR QUALITY)
	2022 ASHRAE 90.1 (ENERGY STANDARD FOR BUILDINGS)
	2023 ASHRAE 189.1 (HIGH-PERFORMANCE GREEN BUILDINGS)
	2024 ASHRAE 202 (HIGH-PERFORMANCE GREEN BUILDINGS)
	2024 ASHRAE 362 (VENTILATION IN HEALTH CARE FACILITIES)
STATUTES	ARIZONA REVISED STATUTES (ARS)
	(AS APPLICABLE TO PUBLIC AND STATE-FUNDED BUILDINGS)
OCCUPATIONAL SAFETY	OCCUPATIONAL SAFETY AND HEALTH ADMINISTRATION (OSHA)
MATERIAL SAFETY	NAU MATERIAL SAFETY POLICIES (E.G., PROGRAM MANUALS FOR ASBESTOS, LEAD, PCBs; LATEST EDITIONS UNLESS OTHERWISE REQUIRED)
INDOOR AIR QUALITY	SMACNA IAQ GUIDELINES FOR OCCUPIED BUILDING CONSTRUCTION (LATEST EDITION UNLESS OTHERWISE REQUIRED)
LABORATORY VENTILATION	2022 LABORATORY VENTILATION (ANSI/AIA 29.5) (LATEST EDITION UNLESS OTHERWISE REQUIRED)
INDUSTRIAL VENTILATION	ACGIH INDUSTRIAL VENTILATION MANUAL (LATEST EDITION UNLESS OTHERWISE REQUIRED)
NAU STANDARDS	2025 NAU DESIGN GUIDELINES & TECHNICAL STANDARDS (LATEST PUBLISHED VERSION; E.G., MARCH 4, 2025. WHERE DISCREPANCIES ARISE BETWEEN NAU GUIDELINES AND FEDERAL, STATE, OR LOCAL BUILDING CODES, RESOLUTION IS REQUIRED BY THE ARCHITECT/ENGINEER OF RECORD AND NAU'S FACILITIES AND PLANS REVIEW TEAM.)
	- AZ ELEVATOR ACT (TITLE 23, CHAPTER 2, ARTICLE 12)
	- LATEST ADOSH ARIZONA ELEVATOR RULES

DEFERRED SUBMITTALS

-N/A-

OWNER DATA

OWNER:	ARIZONA BOARD OF REGENTS NORTHERN ARIZONA UNIVERSITY
PROJECT ADDRESS:	1050 S. KNOLES DR. FLAGSTAFF, AZ 86011
FACILITY NUMBER	BUILDING 30 [FIELDHOUSE]
NAU REP:	NAU FACILITIES SERVICES GABRIEL GURRIOLA

SHEET INDEX

SHT #	NAME	ISSUED	REVISED
G0.00	COVER	03.16.2026	
G0.01	INDEX, LEGEND & GENERAL PROJECT DATA	03.16.2026	05.06.2026
AD2.00	LEVEL 01 DEMOLITION CEILING PLAN	03.16.2026	
A2.00	LEVEL 01 OVERALL CEILING PLAN	03.16.2026	
A4.00	BUILDING ELEVATIONS & SECTIONS	03.16.2026	
S0.01	GENERAL STRUCTURAL NOTES	03.16.2026	
S1.01	ENLARGED MECH'L FLOOR PLANS	03.16.2026	
S2.01	FRAMING DETAILS	03.16.2026	
M000	MECHANICAL COVER SHEET	03.16.2026	
MD100	MECHANICAL DEMOLITION PLAN	03.16.2026	
M100	MECHANICAL DUCTWORK PLAN	03.16.2026	05.06.2026
M101	MECHANICAL PIPING PLAN	03.16.2026	
M300	MECHANICAL SCHEDULES & DETAILS	03.16.2026	05.06.2026
M301	MECHANICAL CONTROLS	03.16.2026	05.06.2026
M302	MECHANICAL CONTROLS	03.16.2026	05.06.2026
E000	ELECTRICAL COVER SHEET	03.16.2026	
ED100	ELECTRICAL POWER DEMOLITION PLAN	03.16.2026	
E100	ELECTRICAL POWER PLAN	03.16.2026	
E500	ONE-LINE DIAGRAM	03.16.2026	
E501	ELECTRICAL SCHEDULES	03.16.2026	

BUILDING COMMISSIONING REQUIREMENTS

- HEATING, VENTILATION, AIR CONDITIONING AND REFRIGERATION (HVAC&R) SYSTEMS (MECHANICAL AND PASSIVE) AND ASSOCIATED CONTROLS INCLUDING:
 - NEW AIR HANDLING UNITS - FH-1, FH-2, AND HV-1
 - MECHANICAL HYDRONIC WATER SYSTEMS INCLUDING:
 - HYDRONIC CONTROL VALVES
 - HYDRONIC PIPING
 - ADJUSTMENT OF PUMPS AND PUMP CONTROLS AS REQUIRED.
- NOTE:** A COMMISSIONING PLAN SHALL BE DEVELOPED BY THE OWNER'S SELECTED COMMISSIONING AGENT IN COMPLIANCE WITH IECC 408.2.1. A PRELIMINARY COMMISSIONING REPORT SHALL BE COMPLETED BY THE SUBMISSION OF THE COMMISSIONING COMPLIANCE CHECK LIST PER FIGURE C408.2.4.

PROJECT DIRECTORY

Architect	LIGHTVOX STUDIO 4602 E THOMAS RD STE 100 PHOENIX, AZ 85018 contact: BENJAMIN MULLINGS o 6 0 2 . 6 0 4 . 6 6 2 6
Mech/Electrical	IMEG 9000 E PIMA CENTER PARKWAY, STE 320, SCOTTSDALE, AZ 85258 contact: HUGO A. CHAIREZ o 4 8 0 . 5 6 6 . 2 2 6 8
Structure	RUDOW + BERRY 4032 N MILLER RD STE 100 SCOTTSDALE, AZ 85251 contact: MARK RUDOW o 4 8 0 . 9 4 6 . 8 1 7 1

1	ADDENDUM 001	05.06.2026
--	100% CD ISSUANCE	03.16.2026

NO.	DESCRIPTION	DATE
-----	-------------	------

LIGHTVOX STUDIO PLLC
o 602.604.6626
info@lightvoxstudio.com
4602 E Thomas Rd Ste 100
Phoenix AZ 85018

PROJECT:
**NAU Fieldhouse
HVAC Replacement**

3001.18.01/09.300.251
1050 S KNOLES DR.
FLAGSTAFF, AZ 86011

**INDEX, LEGEND &
GENERAL PROJECT
DATA**

GO.01

AIR HANDLING SCHEDULE

NOTES:
 1. PROVIDE SHAFT GROUNDING AS REQUIRED IN THE MOTOR SPECIFICATION 23 05 13.
 2. AHU TO BE FURNISHED WITH A GLYCOL COIL. GLYCOL COIL TO BE CONNECTED IN A FUTURE PHASE AND NOT INCLUDED IN THE SCOPE OF THIS PROJECT.

TAG NAME	AREA SERVED	SUPPLY FAN (NOTE 1)						ELECTRICAL				HEATING COIL - WATER				COOLING COIL				GLYCOL COIL				FILTER			WEIGHT	MANUFACTURER	MODEL	NOTES																							
		NO. OF FANS	CFM TOTAL	EXT. S.P. (NOTE D)	RPM (NOTE E)	BHP EACH (NOTE E)	MHP EACH (NOTE E)	MINIMUM OUTSIDE AIR CFM	VOLTAGE	PHASES	DISCONNECT(S)		CONTROLLER STARTER(S)		SCCR	EAT 'F	LAT 'F	EWT 'F	LWT 'F	GPM	MBH	MAX. A.P.D. IN. W.C.	W.P.D. FEET HEAD	EAT DB 'F	EAT WB 'F	LAT DB 'F					LAT WB 'F	EWT 'F	LWT 'F	GPM	TOTAL MBH	MAX. A.P.D. IN. W.C.	W.P.D. FEET HEAD	CFM	EAT DB 'F	EAT WB 'F	LAT DB 'F	LAT WB 'F	EWT 'F	LWT 'F	GPM	TOTAL MBH	MAX. A.P.D. IN. W.C.	W.P.D. FEET HEAD	GLYCOL %	PRE-FILTER			
											BY (NOTE A)	TYPE (NOTE B)	BY (NOTE A)	TYPE (NOTE C)																																				TYPE	FACE VELOCITY	PRESSURE DROP DIRTY	PRESSURE DROP CLEAN
FH-1	FIELDHOUSE	2	8000	2.5	2181	4.31	6.97	0	460	3	EC	F	MFR	MS	5000	38.0	96.8	140	100	19.20	396.31	1.00	6.6	63.7	60.0	48.3	48.0	42	56	36.13	255	0.88	17.8	8000	48.3	48.2	38.1	38.1	33	39.1	67.6	178	1.24	9.76	40	MERV 8	406	1.0	0.17	3599	DAIKIN	VISION	1.2
FH-2	FIELDHOUSE	2	8000	2.5	2181	4.31	6.97	0	460	3	EC	F	MFR	MS	5000	38.0	96.8	140	100	19.20	396.31	1.00	6.6	63.7	60.0	48.3	48.0	42	56	36.13	255	0.88	17.8	8000	48.3	48.2	38.1	38.1	33	39.1	67.6	178	1.24	9.76	40	MERV 8	406	1.0	0.17	3599	DAIKIN	VISION	1.2
HV-1	FIELDHOUSE	3	13500	4.3	2570	3.13	6.97	13500	460	3	EC	F	MFR	MS	5000	0.0	85.4	140	100	48.40	971.70	0.93	6.2	0.0	0.0	0.0	0.0	0	0	0.00	0	0.00	0.0	0	0.0	0.0	0.0	0	0.0	0.0	0	MERV 8	486	1.0	0.22	1784	DAIKIN	CAC015GHAM	1				

GRILLES REGISTERS & DIFFUSERS SCHEDULE

SYMBOL	MATL	TYPE	MARGIN (NOTE 1)	INLET SIZE (INCH)	FACE SIZE (INCH)	VOLUME DAMPER REQ'D	FINISH	MANUFACTURER	MODEL	REMARKS
SG-1	STEEL	DOUBLE DEFLECTION	1 1/4"	SEE DWG.	INLET +2	NO	WHITE	TITUS	132RL	1
SG-2	STEEL	DOUBLE DEFLECTION	1 1/4"	SEE DWG.	INLET +2	NO	WHITE	TITUS	132RL	1

NOTES:
 1. CONTRACTOR SHALL DETERMINE PROPER MARGIN STYLE TO MATCH CEILING CONSTRUCTION.

VENTILATION CALCULATION (IMC_2021)

UNIT MARK	SPACE NUMBER	SPACE NAME	SPACE AREA (A _z)	OCCUPANT DENSITY	CALCULATED OCCUPANTS	FIXED SEATS	OCCUPANCY (P _z)	OUTDOOR AIR (R _p)	OUTDOOR AIR (R _a)	OUTDOOR AIR (R _p P _z)	OUTDOOR AIR (R _a A _z)	EXHAUST AIR	EXHAUST OVERRIDE	EFFECTIVENESS (E _z)	PLUM FIXTURE	FIXTURE EXHAUST	OUTDOOR AIR (V _{oz})	EXHAUST AIR
		[N/A]	[SQFT]	[#/1000 SQFT]	[Ppl Qty]	[Qty]	[Ppl Qty]	[CFM/Person]	[CFM/SQFT]	[CFM]	[CFM]	[CFM/SQFT]	[CFM/SQFT]	[N/A]	[Qty]	[CFM/Fixt.]	[CFM]	[CFM]
TOTAL BUILDING	140	FIELDHOUSE	41322	7.0	289.3		289.3	20.0	0.18	5785.08	7437.96	0.0		0.8			16529	0
TOTAL:																	16529	0

VENTILATION CALCULATION NOTES:
 1. THE CALCULATION ABOVE WAS PRODUCED USING THE TOTAL AREA OF THE FIELDHOUSE, RAN AS A "GYM, STADIUM, ARENA (PLAY AREA)" PER IMC 2021.
 2. OUT OF THE 16529 CFM OF OUTSIDE AIR REQUIRED, 13500 IS PROVIDED BY HV-1 AND E-HV-1/E-HV-5 WILL EACH PROVIDE 1515 CFM OF OUTSIDE AIR FOR A TOTAL OF 16530 CFM OF OUTSIDE AIR.

SCHEDULE GENERAL NOTES:

- A. DISCONNECT AND CONTROLLER STARTER FURNISHED AND INSTALLED BY:
 - MFR = MANUFACTURER
 - EC = ELECTRICAL CONTRACTOR
 - MC = FURNISHED BY MECHANICAL CONTRACTOR, INSTALLED BY ELECTRICAL CONTRACTOR
 - MFR/EC = FURNISHED LOOSE BY MANUFACTURER INSTALLED BY ELECTRICAL CONTRACTOR
 - ATC = AUTOMATIC TEMPERATURE CONTROL CONTRACTOR
- B. DISCONNECT TYPE:
 - F = FUSED
 - NF = NON-FUSED
- C. CONTROLLER STARTER TYPE:
 - FV = FULL VOLTAGE
 - WYE = WYE-DELTA
 - SS = SOLID STATE (SOFT START)
 - MS = MANUAL STARTER
 - VFD = VARIABLE FREQUENCY DRIVE
 - VFD/B = VARIABLE FREQUENCY DRIVE WITH BYPASS
- D. FAN RPM SHALL NOT EXCEED 110% OF SCHEDULED VALUE, WITH THE SCHEDULED WHEEL TYPE. SUBSTITUTION OF BI OR BIA FANS FOR FC IS ACCEPTABLE IF EFFICIENCY IS NOT LOWER.
- E. NO EQUIPMENT SHALL BE SELECTED ABOVE 90% OF MOTOR NAME PLATE RATING.
- F. MUST BE WITHIN +/- 10% OF SCHEDULED RPM.
- G. CURB TYPE:
 - MFR = STANDARD CURB BY MANUFACTURER
 - GC = BY GENERAL CONTRACTOR
 - SAC = SOUND ATTENUATOR CURB

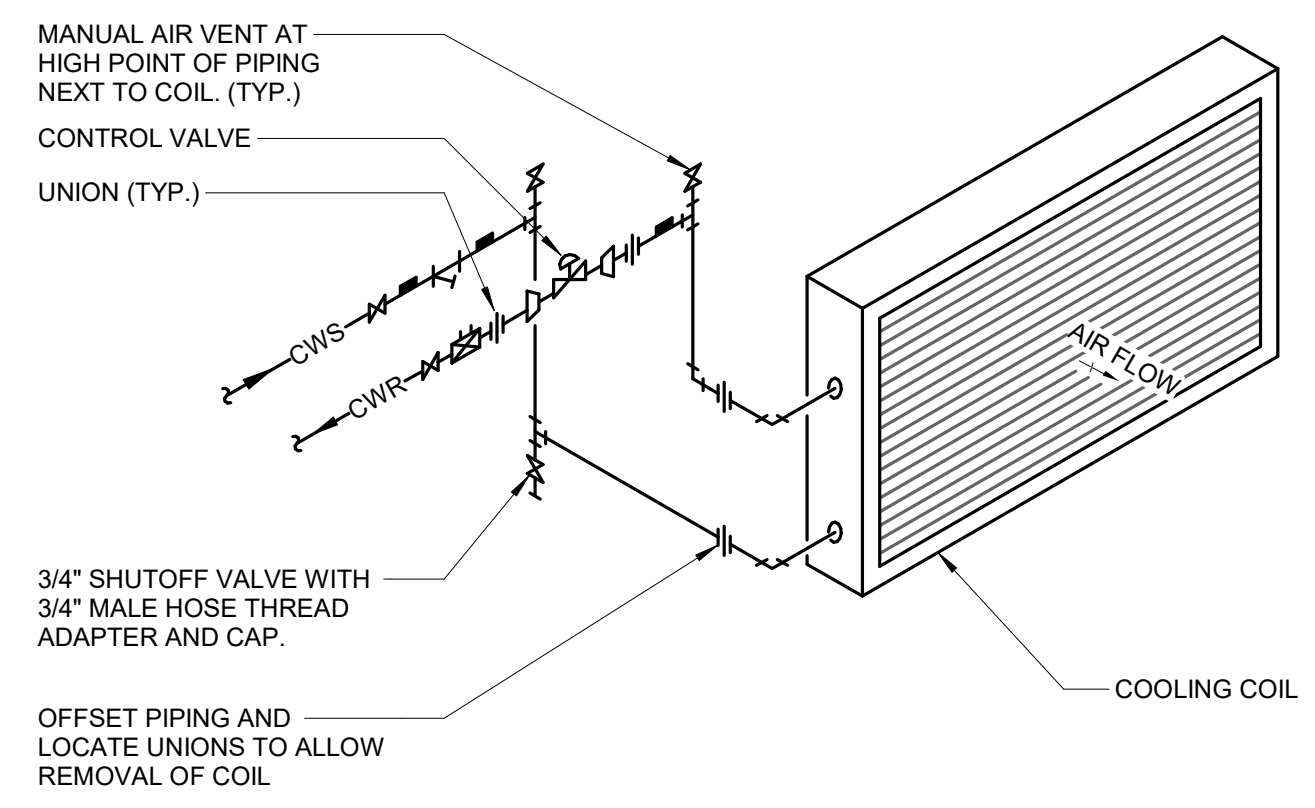

NOTES:
 1. SEE SPECIFICATION SECTION 23 21 00 - HYDRONIC PIPING FOR BALANCE VALVE SIZING REQUIREMENTS.

1 COIL - CHILLED WATER PIPING DIAGRAM W/2-WAY VALVE

NO SCALE

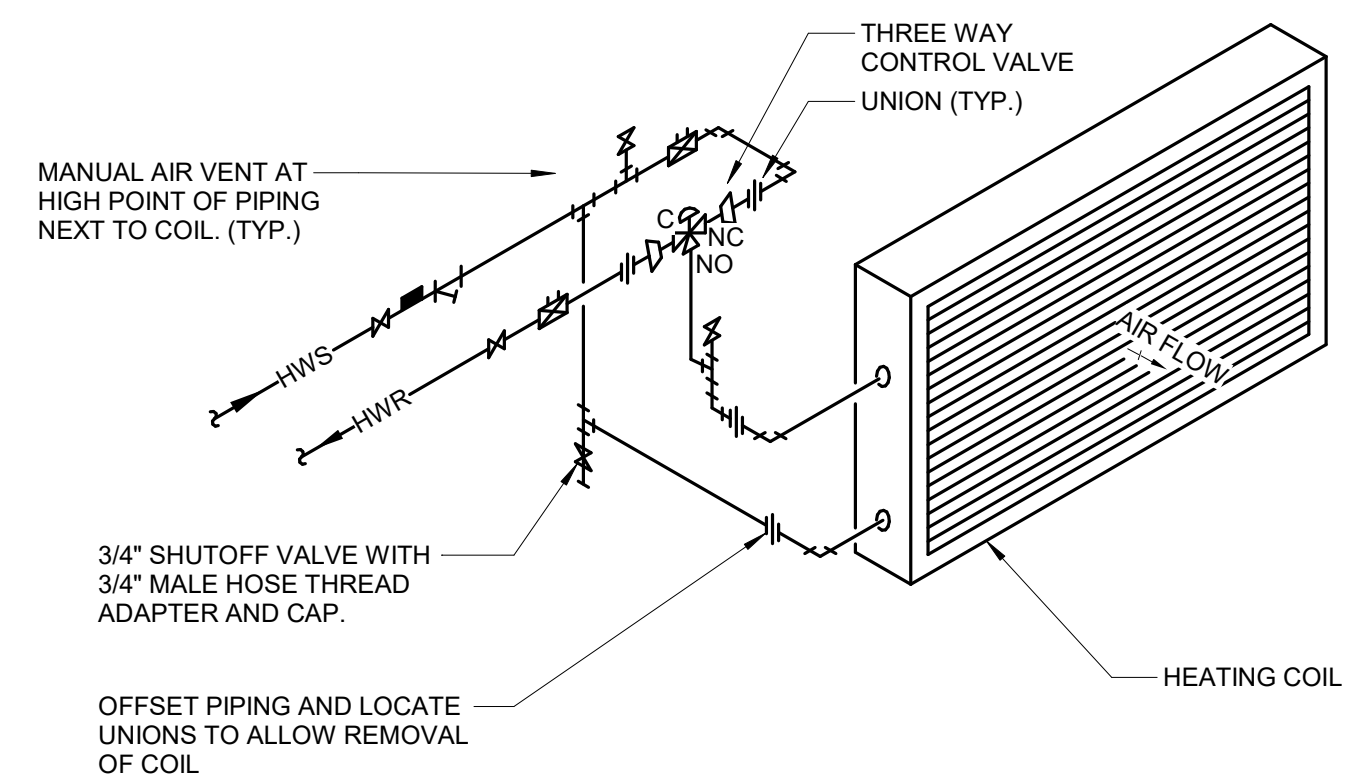

NOTES:
 1. SEE SPECIFICATION SECTION 23 21 00 - HYDRONIC PIPING FOR BALANCE VALVE SIZING REQUIREMENTS.

2 COIL - HOT WATER PIPING DIAGRAM W/3-WAY VALVE

NO SCALE

1	ADDENDUM 001	05.06.26
-	100% CD ISSUANCE	03.16.26
NO.	DESCRIPTION	DATE

LIGHTVOX STUDIO PLLC
 602.604.6626
 info@lightvoxstudio.com
 4602 E Thomas Rd Ste 100
 Phoenix AZ 85018

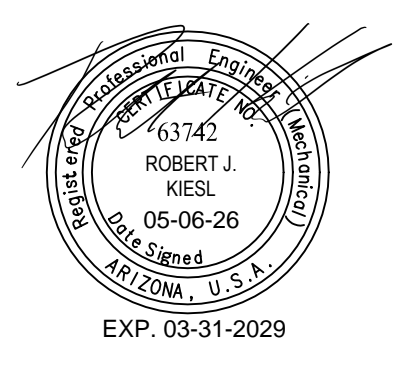

PROJECT:
[FMF] Fieldhouse HVAC Scope

09.300.251
 1050 S KNOLES DR.
 FLAGSTAFF, AZ 86011

MECHANICAL SCHEDULES & DETAILS

M300

IMEG RESERVES PROPRIETARY RIGHTS, INCLUDING COPYRIGHTS, TO THIS DRAWING AND THE DATA SHOWN THEREON. SAID DRAWING AND/OR DATA ARE THE EXCLUSIVE PROPERTY OF IMEG AND SHALL NOT BE USED OR REPRODUCED FOR ANY OTHER PROJECT WITHOUT THE EXPRESS WRITTEN APPROVAL AND PARTICIPATION OF IMEG. ©2024 IMEG CONSULTANTS CORP.

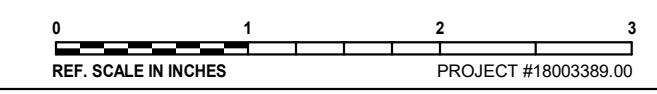

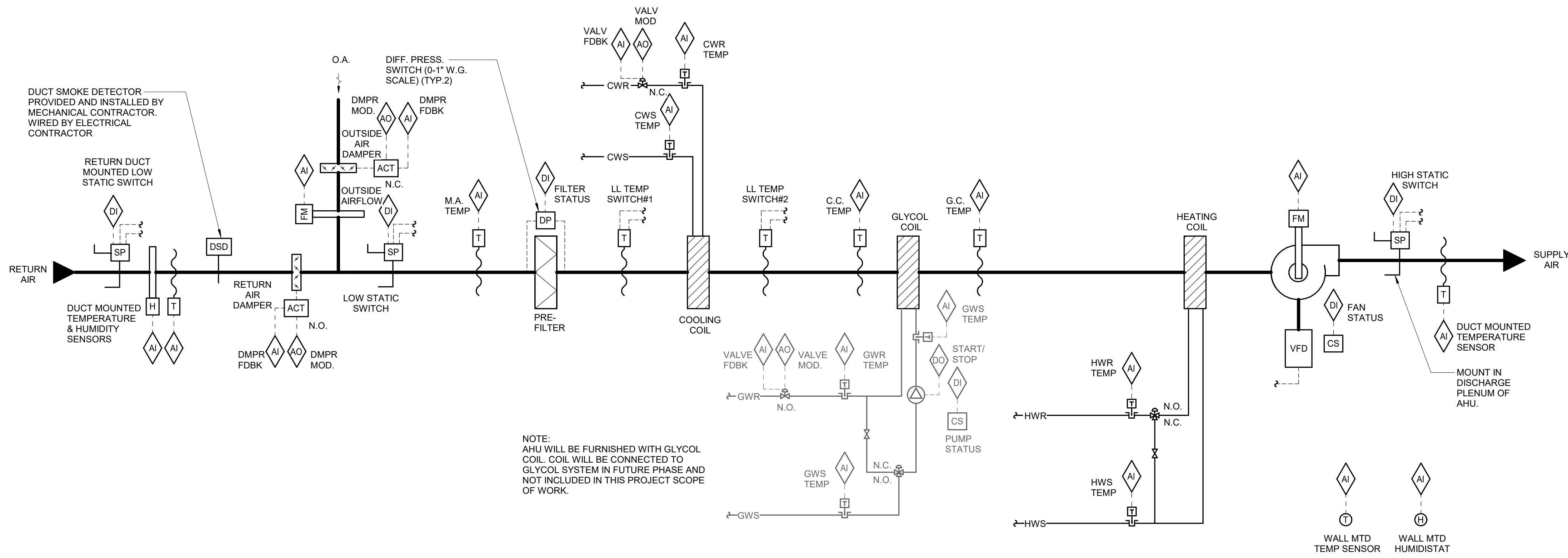

NOTE:
AHU WILL BE FURNISHED WITH GLYCOL COIL. COIL WILL BE CONNECTED TO GLYCOL SYSTEM IN FUTURE PHASE AND NOT INCLUDED IN THIS PROJECT SCOPE OF WORK.

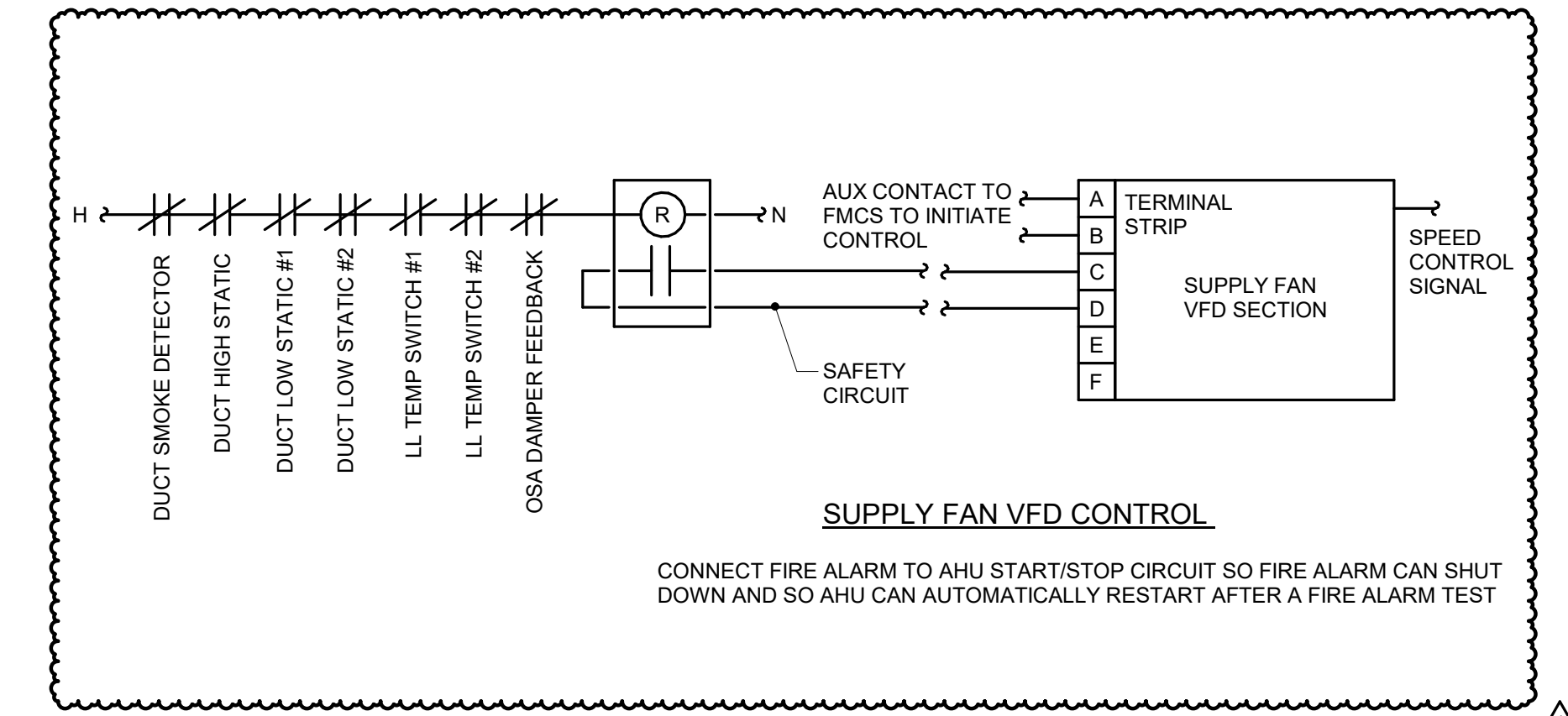

CONNECT FIRE ALARM TO AHU START/STOP CIRCUIT SO FIRE ALARM CAN SHUT DOWN AND SO AHU CAN AUTOMATICALLY RESTART AFTER A FIRE ALARM TEST

AHU REPORT GENERATION:
DDC FMCS SHALL MONITOR THE FOLLOWING POINTS ON 10 MINUTE (ADJ.) INTERVALS WITHIN A SINGLE TREND. THE TREND SHALL RUN FOR A 14-DAY (ADJ.) DURATION AT WHICH POINT THE NEWEST VALUES SHALL AUTOMATICALLY OVERWRITE THE OLDEST VALUES:

- DATE
- TIME
- GLOBAL OUTSIDE AIR TEMP [°F]
- GLOBAL OUTSIDE AIR DEWPOINT [°F]
- GLOBAL OUTSIDE AIR HUMIDITY [%RH]
- SUPPLY AIRFLOW [CFM]
- SUPPLY AIR TEMP (SAT) [°F]
- SUPPLY AIR RELATIVE HUMIDITY [%]
- ROOM AIR TEMP SETPOINT [°F]
- RETURN AIR TEMP (RAT) [°F]
- RETURN AIR RELATIVE HUMIDITY [%]
- OUTSIDE AIRFLOW [CFM]
- MIXED AIR TEMP [°F]
- PRE-FILTER ALARM [STATUS]
- HEATING WATER VALVE POSITION [% OPEN]
- HEATING PUMP [ON/OFF]
- PREHEAT COIL DISCHARGE AIR TEMPERATURE [°F]
- CHILLED WATER VALVE POSITION [% OPEN]
- SUPPLY FAN VFD OUTPUT [% FULL SPEED]
- OUTSIDE AIR DAMPER POSITION [% OPEN]
- RETURN AIR DAMPER POSITION [% OPEN]

THIS INFORMATION SHALL BE ACCESSIBLE TO VIEW IN EITHER TABULAR OR GRAPHICAL FORM ON THE FMCS OPERATOR WORKSTATION.

TRENDING REQUIREMENTS:
DIGITAL POINTS: RECORD EVERY CHANGE OF ACTION WITH CORRESPONDING TIME STAMP FOR POINTS LISTED.
ANALOG POINTS: RECORD EVERY 15 MINUTES WITH CORRESPONDING TIME STAMP FOR POINTS LISTED.

THIS INFORMATION SHALL BE STORED TO A MEMORY LOCATION ON THE FMCS OPERATOR WORKSTATION THAT IS MAINTAINED FOR A PERIOD OF ONE YEAR.

AIR HANDLER REPORT GENERATION

GENERAL NOTES:

- MINIMUM HEATING AND COOLING CFM: FAN MINIMUM.
- CONTROLS CONTRACTOR SHALL PROVIDE IN THEIR BID A MINIMUM OF TWO 1-HOUR CONTROLS MEETINGS WITH NAUS CONTROLS AND MAINTENANCE TEAM TO REVIEW THE CONTROL REQUIREMENTS OF THE JOB.

SEQUENCE OF OPERATION:

WHEN AHU IS INDEXED TO RUN, THE FOLLOWING SHALL OCCUR:

- SUPPLY FAN SHALL BE ENABLED TO RUN.

SUPPLY FAN AND CONTROL VALVE OPERATION:
THE FMCS SHALL MODULATE THE SUPPLY FAN, COOLING CONTROL VALVE, AND HEATING CONTROL VALVE TO ACHIEVE THE ROOM TEMPERATURE OF 72°F (ADJ.) WITH 5°F (ADJ.) DEAD BAND BASED ON A SIGNAL FROM A WALL MOUNTED TEMPERATURE SENSOR. SPACES WITH ADJUSTABLE THERMOSTATS WILL ALLOW A +/- 3°F (ADJ.) OFFSET FROM THE SETPOINT.

- AT FULL COOLING, THE SUPPLY FAN SHALL RUN AT MAXIMUM COOLING CFM SPEED AND THE COOLING COIL CONTROL VALVE SHALL BE OPEN TO MAINTAIN 55°F (ADJ.) DISCHARGE AIR TEMPERATURE.
- AS THE ROOM AIR TEMPERATURE FALLS, THE SUPPLY FAN SHALL RAMP DOWN TO MAINTAIN ROOM TEMPERATURE SETPOINT WHILE MAINTAINING A 55°F (ADJ.) DISCHARGE AIR TEMPERATURE SETPOINT.
- ON A FURTHER FALL IN ROOM TEMPERATURE, THE SUPPLY FAN SHALL REMAIN AT MINIMUM SPEED AND THE COOLING CONTROL VALVE SHALL MODULATE TO MAINTAIN ROOM AIR TEMPERATURE SETPOINT. WHEN THE SUPPLY FAN IS AT MINIMUM SPEED THE AHU DISCHARGE AIR TEMPERATURE SHALL NOT CONTROL THE COOLING CONTROL VALVE.
- ON A FURTHER REDUCTION IN ROOM TEMPERATURE, THE COOLING CONTROL VALVE SHALL FULLY CLOSE AND THE HEATING CONTROL VALVE SHALL MODULATE OPEN TO MAINTAIN ROOM AIR TEMPERATURE SETPOINT. THE DISCHARGE AIR TEMPERATURE SHALL NOT RISE ABOVE 95°F AS THE HEATING CONTROL VALVE OPENS. THE SUPPLY FAN SHALL REMAIN AT MINIMUM HEATING CFM.
- ONCE THE HEATING CONTROL VALVE IS MAINTAINING 95°F DISCHARGE AIR, THE SUPPLY FAN SPEED SHALL RAMP UP TO MAXIMUM HEATING SPEED TO MAINTAIN ROOM AIR TEMPERATURE SETPOINT.

WHEN IN ECONOMIZER MODE, FMCS SHALL NOT MODULATE COOLING CONTROL VALVE UNLESS RETURN AIR DAMPER IS 5% (ADJ.) OR LESS OPEN.

DISCHARGE AIR TEMPERATURE:
THE DISCHARGE AIR TEMPERATURE SHALL BE BETWEEN 55°F (ADJ.) AND 95°F (ADJ.) TO MAINTAIN ROOM TEMPERATURE SETPOINT.

ECONOMIZER OPERATION:
WHEN THE OUTSIDE AIR ENTHALPY IS LESS THAN THE RETURN AIR ENTHALPY THE FMCS SHALL ENABLE ECONOMIZER CONTROLS. WHEN OUTSIDE AIR ENTHALPY IS GREATER THAN THE RETURN AIR ENTHALPY FOR 10 MINUTES THE FMCS SHALL DISABLE ECONOMIZER CONTROLS AND SHALL RETURN THE UNIT TO MINIMUM OUTSIDE AIR MODE. ONCE ECONOMIZER CONTROLS HAVE BEEN ENABLED OR DISABLED, THE UNIT SHALL CONTINUE TO OPERATE IN THAT MODE FOR A MINIMUM OF 10 MINUTES (ADJ.) BEFORE BEING ALLOWED TO SWITCH BACK (TO PREVENT SHORT CYCLING).

IN ECONOMIZER MODE THE FMCS SHALL MODULATE THE RETURN AND OUTSIDE AIR DAMPERS AS REQUIRED TO MAINTAIN DISCHARGE AIR TEMPERATURE SETPOINT, BUT SHALL NOT ALLOW THE MIXED AIR TEMPERATURE TO DROP BELOW 38°F.

OUTSIDE AIR DAMPER OPERATION SHALL ONLY BE ENABLED WHEN ECONOMIZER CONTROLS ARE ENABLED, OTHERWISE OUTSIDE AIR DAMPER SHALL REMAIN CLOSED AND RETURN AIR DAMPER SHALL REMAIN FULLY OPEN.

DEHUMIDIFICATION:
IF THE SPACE HUMIDITY SENSOR EXCEEDS 60% RH (ADJ.), DEHUMIDIFICATION CONTROLS SHALL BE ENABLED. IF THE SPACE HUMIDITY SENSOR IS BELOW 55% RH (ADJ.), DEHUMIDIFICATION SEQUENCE SHALL BE DISABLED. ONCE DEHUMIDIFICATION CONTROLS ARE ENABLED OR DISABLED, THE UNIT SHALL CONTINUE TO OPERATE IN THAT MODE FOR A MINIMUM OF 10 MINUTES (ADJ.) BEFORE BEING ALLOWED TO SWITCH BACK (TO PREVENT SHORT CYCLING).

WHEN DEHUMIDIFICATION CONTROLS ARE ENABLED, THE FOLLOWING SHALL OCCUR:

- THE SUPPLY FAN SHALL RUN AT MAXIMUM COOLING CFM AND THE COOLING COIL LEAVING AIR TEMPERATURE SETPOINT SHALL BE SET TO 48°F (ADJ.)
- THE HEATING COIL CONTROL VALVE SHALL BE ENABLED AND SHALL MODULATE TO MAINTAIN A LEAVING AIR TEMPERATURE BETWEEN 55°F (ADJ.) AND 95°F (ADJ.) TO MAINTAIN ROOM TEMPERATURE SETPOINT.

ALARMS, INTERLOCKS, AND SAFETIES:
WHEN FIRE ALARM CONTROL PANEL INDICATES AN ALARM CONDITION, AHU SHALL BE SHUTDOWN.

THE FOLLOWING CONDITIONS SHALL SHUTDOWN THE AHU AND SHALL INDICATE AN ALARM CONDITION AT THE FMCS WORKSTATION:

- LOW STATIC PRESSURE SWITCH INDICATES RETURN DUCT PRESSURE LESS THAN THE SPECIFIED DUCT PRESSURE CLASS.
- LOW STATIC PRESSURE SWITCH INDICATES MIXED AIR PRESSURE LESS THAN THE SPECIFIED DUCT PRESSURE CLASS OF THE OUTSIDE AIR DUCTWORK.
- HIGH STATIC PRESSURE SWITCH INDICATES SUPPLY DUCT STATIC PRESSURE GREATER THAN THE SPECIFIED DUCT PRESSURE CLASS.
- DUCT SMOKE DETECTOR INDICATES SMOKE IN THE SYSTEM.
- SHOULD ANY ONE FOOT SECTION OF THE MANUAL RESET LOW LIMIT TEMPERATURE SWITCH #1 OR #2 SENSE AIR TEMP <35°F (ADJ.), IF MULTIPLE FREEZE STATS ARE REQUIRED, LOCATE ADJACENT TO EACH OTHER TO BE RESET BY A COMMON LATCHING RELAY.
- SHOULD THE OUTSIDE AIR DAMPER BE COMMANDED TO CLOSE AND THE DAMPER FEEDBACK INDICATES THE POSITION HAS NOT CHANGED AFTER 30 SECONDS.

THE FOLLOWING CONDITIONS SHALL INDICATE WHICH DEVICE IS IN AN ALARM AT THE FMCS AND SHALL INDICATE WHICH DEVICE IS IN AN ALARM CONDITION, HOWEVER AHU SHALL CONTINUE TO OPERATE:

- AN ALARM IS INDICATED AT ANY SUPPLY FAN VFD OR RETURN FAN VFD.
- DIFFERENTIAL PRESSURE SWITCH ACROSS PRE-FILTER BANK EXCEEDS 0.8 INCHES W.G. (ADJ.)
- SEND AN ALARM TO THE FMCS OPERATOR INTERFACE IF THE SPACE TEMPERATURE IS MORE THAN 10°F (ADJ.) ABOVE OR BELOW SETPOINT.

IN THE EVENT SUPPLY FAN IS NOT RUNNING (AS INDICATED BY THE CURRENT SENSING RELAYS) RETURN AIR FAN SHALL BE DE-ENERGIZED.

IN THE EVENT THAT THE AIR HANDLER IS SHUTDOWN AS A RESULT OF THE MANUAL RESET LOW LIMIT TEMPERATURE SWITCH OR OUTSIDE AIR DAMPER FAILURE, THE FOLLOWING SHALL OCCUR:

- ALL COOLING AND HEATING CONTROL VALVES SHALL MODULATE FULLY OPEN TO PREVENT COIL RUPTURE.
- ALL OTHER SHUTDOWN REQUIREMENTS/SEQUENCES SHALL REMAIN.

WHENEVER AHU IS SHUTDOWN THE FOLLOWING SHALL OCCUR:

- THE OUTSIDE AIR DAMPER SHALL FULLY CLOSE AND THE RETURN AIR DAMPER SHALL FULLY OPEN.
- HEATING CONTROL VALVE SHALL REMAIN UNDER CONTROL OF ITS INPUT SENSOR.
- COOLING CONTROL VALVE SHALL FULLY CLOSE.
- SUPPLY FAN VFDs SHALL BE DE-ENERGIZED.

UNOCCUPIED MODE:
PROVIDE TIME OF DAY SCHEDULE TO ALLOW AHU TO ENTER UNOCCUPIED MODE PER SCHEDULE. COORDINATE SCHEDULE WITH OWNER.

- THE SUPPLY FANS SHALL CONTINUE RUNNING.
- THE OUTSIDE AIR DAMPER SHALL CLOSE AND THE RETURN AIR DAMPER SHALL OPEN. ECONOMIZER CYCLE SHALL TAKE PRECEDENCE OVER DAMPER POSITION.
- ALL SPACE TEMPERATURES SHALL BE ALLOWED TO VARY +/- 10°F (ADJ.) FROM OCCUPIED SETPOINT.

HEATING OPTIMUM START-UP:
THIS CYCLE SHALL OVERRIDE THE UNOCCUPIED CYCLE. IF THE SYSTEM WAS OPERATING AS A RESULT OF THE UNOCCUPIED CYCLE, THE SYSTEM SHALL CONTINUE TO OPERATE. THE DDC SYSTEM SHALL DETERMINE THE MINIMUM RUNTIME TO WARM THE SPACES TO THEIR SETPOINT WHEN THE COMPUTED START TIME IS REACHED. THE AIR HANDLING UNIT DISCHARGE AIR TEMPERATURE SHALL BE MAINTAINED AT A SETPOINT OF 85°F (ADJ.). THE SYSTEM SHALL CONTINUE TO OPERATE IN THIS MODE UNTIL ALL TEMPERATURES EXCEED A SETPOINT OF 75°F (ADJ.). AT THAT TIME, THE DDC SYSTEM SHALL SWITCH TO OCCUPIED CONTROL.

COOLING OPTIMUM START-UP:
THIS CYCLE SHALL OVERRIDE THE UNOCCUPIED CYCLE. IF THE SYSTEM WAS OPERATING AS A RESULT OF THE UNOCCUPIED CYCLE, THE SYSTEM SHALL CONTINUE TO OPERATE. THE DDC SYSTEM SHALL DETERMINE THE MINIMUM RUNTIME TO COOL THE SPACES TO THEIR SETPOINT WHEN THE COMPUTED START TIME IS REACHED. THE AIR HANDLING UNIT DISCHARGE AIR TEMPERATURE SHALL BE MAINTAINED AT A SETPOINT OF 55°F (ADJ.). THE SYSTEM SHALL CONTINUE TO OPERATE IN THIS MODE UNTIL ALL TEMPERATURES ARE LESS THAN A SETPOINT OF 75°F (ADJ.). AT THAT TIME, THE DDC SYSTEM SHALL SWITCH TO OCCUPIED CONTROL.

GRAPHICAL DISPLAY:
DISPLAY THE GLOBAL OUTSIDE AIR TEMPERATURE AND HUMIDITY ON AHU GRAPHIC PAGE.

1 SINGLE ZONE AIR HANDLING UNIT - FH-1 & FH-2
NO SCALE

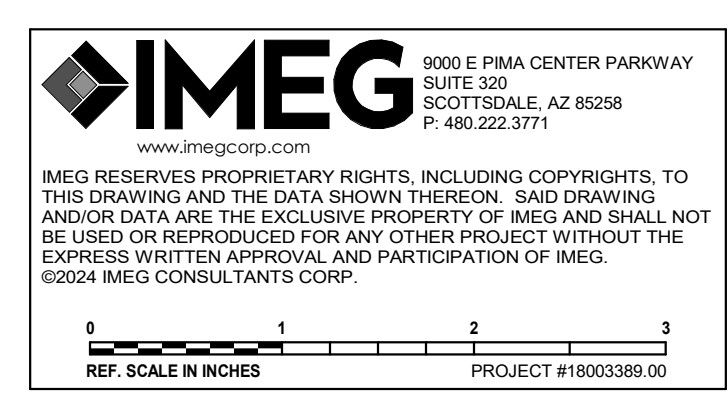

LIGHTVOX STUDIO PLLC
602.604.6626
info@lightvoxstudio.com
4902 E Thomas Rd Ste 100
Phoenix AZ 85018

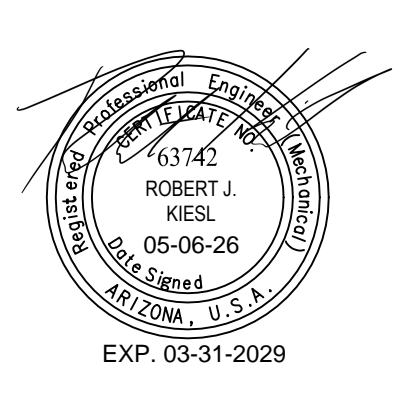

PROJECT:
[FMF] Fieldhouse HVAC Scope

99.300.251
1050 S KNOLES DR.
FLAGSTAFF, AZ 86011

MECHANICAL CONTROLS

M301

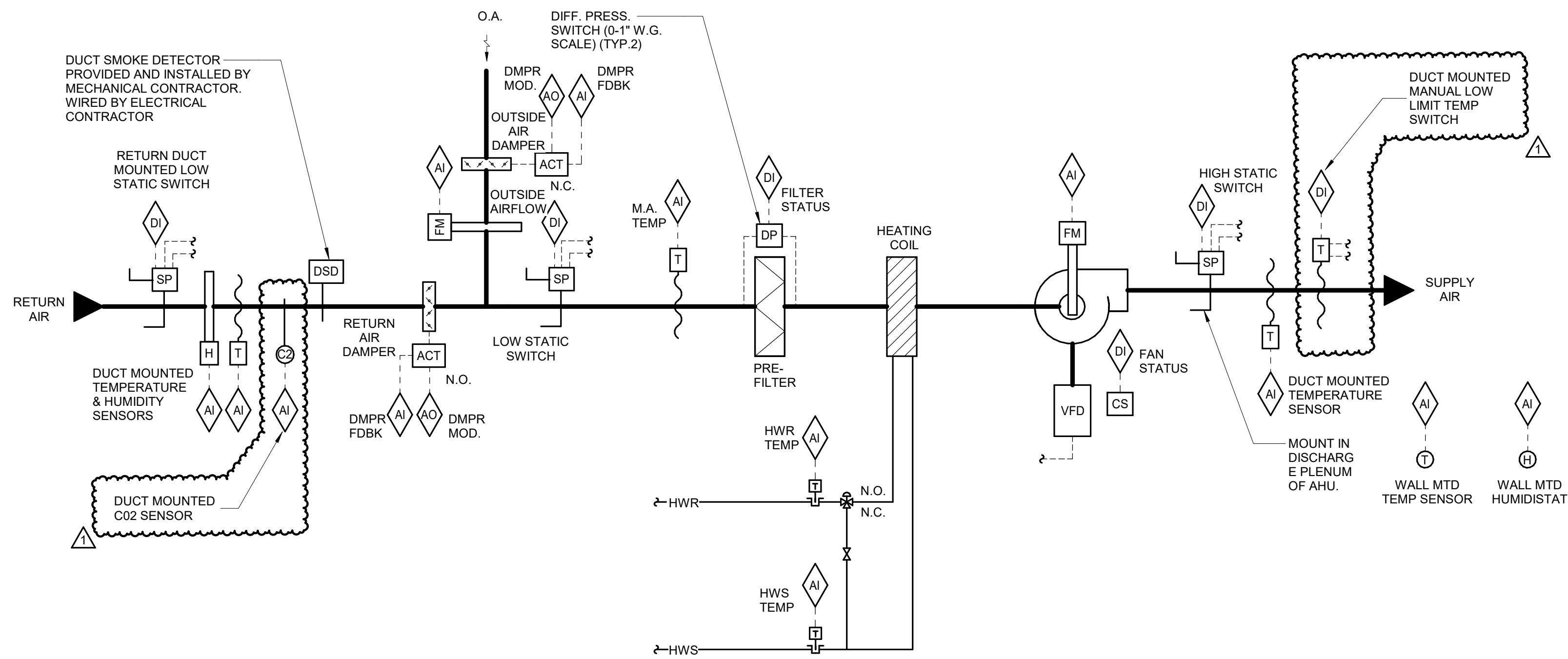

AHU REPORT GENERATION:
 DDC FMCS SHALL MONITOR THE FOLLOWING POINTS ON 10 MINUTE (ADJ.) INTERVALS WITHIN A SINGLE TEND. THE TREND SHALL RUN FOR A 14-DAY (ADJ.) DURATION AT WHICH POINT THE NEWEST VALUES SHALL AUTOMATICALLY OVERWRITE THE OLDEST VALUES:

- DATE
- TIME
- GLOBAL OUTSIDE AIR TEMP [°F]
- GLOBAL OUTSIDE AIR DEWPOINT [°F]
- GLOBAL OUTSIDE AIR HUMIDITY [%RH]
- SUPPLY AIRFLOW [CFM]
- SUPPLY AIR TEMP (SAT) [°F]
- SUPPLY AIR RELATIVE HUMIDITY [%]
- ROOM AIR TEMP SETPOINT [°F]
- RETURN AIR TEMP (RAT) [°F]
- RETURN AIR RELATIVE HUMIDITY [%]
- OUTSIDE AIRFLOW [CFM]
- MIXED AIR TEMP [°F]
- PRE-FILTER ALARM (STATUS)
- HEATING WATER VALVE POSITION [% OPEN]
- HEATING COIL DISCHARGE AIR TEMPERATURE [°F]
- CHILLED WATER VALVE POSITION [% OPEN]
- SUPPLY FAN VFD OUTPUT [% FULL SPEED]
- OUTSIDE AIR DAMPER POSITION [% OPEN]
- RETURN AIR DAMPER POSITION [% OPEN]

THIS INFORMATION SHALL BE ACCESSIBLE TO VIEW IN EITHER TABULAR OR GRAPHICAL FORM ON THE FMCS OPERATOR WORKSTATION.

TRENDING REQUIREMENTS:
 DIGITAL POINTS: RECORD EVERY CHANGE OF ACTION WITH CORRESPONDING TIME STAMP FOR POINTS LISTED.
 ANALOG POINTS: RECORD EVERY 15 MINUTES (ADJ.) WITH CORRESPONDING TIME STAMP FOR POINTS LISTED.

THIS INFORMATION SHALL BE STORED TO A MEMORY LOCATION ON THE FMCS OPERATOR WORKSTATION THAT IS MAINTAINED FOR A PERIOD OF ONE YEAR.

AIR HANDLER REPORT GENERATION

GENERAL NOTES:
 1. CONTROLS CONTRACTOR SHALL PROVIDE IN THEIR BID A MINIMUM OF TWO 1-HOUR CONTROLS MEETINGS WITH NAU'S CONTROLS AND MAINTENANCE TEAM TO REVIEW THE CONTROL REQUIREMENTS OF THE JOB.

SEQUENCE OF OPERATION:
WHEN AHU IS INDEXED TO RUN, THE FOLLOWING SHALL OCCUR:

- SUPPLY FAN SHALL BE ENABLED TO RUN.
- HEATING CONTROL VALVES SHALL BE FULLY OPENED.
- OUTSIDE AIR AND RETURN DAMPERS SHALL BEGIN OPERATION UNDER THE DEMAND CONTROL VENTILATION CONTROL SEQUENCE.

CONTROL VALVE OPERATION:
 THE FMCS SHALL MODULATE THE HEATING CONTROL VALVE TO ACHIEVE THE ROOM TEMPERATURE OF 72°F (ADJ.) WITH 5°F (ADJ.) DEAD BAND BASED ON A SIGNAL FROM A WALL MOUNTED TEMPERATURE SENSOR. SPACES WITH ADJUSTABLE THERMOSTATS WILL ALLOW A +/- 3°F (ADJ.) OFFSET FROM THE SETPOINT.

- WHEN AHU IS INDEX TO RUN, THE HEATING CONTROL VALVE SHALL MODULATE TO MAINTAIN ROOM AIR TEMPERATURE SETPOINT. THE DISCHARGE AIR TEMPERATURE SHALL NOT RISE ABOVE 99°F AS THE HEATING CONTROL VALVE OPENS.

DISCHARGE AIR TEMPERATURE:
 THE DISCHARGE SHALL BE BETWEEN 65°F (ADJ.) AND 95°F (ADJ.) TO MAINTAIN ROOM TEMPERATURE SETPOINT.

DEMAND CONTROL VENTILATION BASED ON CO2 SENSOR:
 TO CONTROL OUTSIDE AIRFLOW AND REDUCE FAN ENERGY, WHENEVER THE AIR HANDLING UNIT IS IN OCCUPIED MODE, THE OUTSIDE AIR DAMPER SHALL BE FULLY OPEN. THE RETURN AIR DAMPER SHALL MODULATE IN OPPOSITION TO MAINTAIN THE MINIMUM OUTSIDE AIR FLOW RATE, OR TO SATISFY THE ECONOMIZER DISCHARGE AIR SEQUENCE. THE MINIMUM OUTSIDE AIR FLOW RATE SHALL BE RESET BY THE FMCS EVERY 5 MINUTES (ADJ.):

- WHEN THE ZONE CO2 SENSOR READING INDICATES THAT THE ZONE CO2 CONCENTRATION IS LESS THAN AMBIENT CONCENTRATION OF 1000 PPM (ADJ.), THE MINIMUM OUTSIDE AIR VOLUME SHALL BE 7400 CFM (ADJ.)
- WHEN THE ZONE CO2 CONCENTRATION IS EQUAL TO OR HIGHER THAN THE CO2 SETPOINT OF 1000 PPM (ADJ.), THE OUTSIDE AIR FLOW RATE SHALL BE 13500 CFM (ADJ.).

ALARMS, INTERLOCKS, AND SAFETIES:
 WHEN FIRE ALARM CONTROL PANEL INDICATES AN ALARM CONDITION, AHU SHALL BE SHUTDOWN.

THE FOLLOWING CONDITIONS SHALL SHUTDOWN THE AHU AND SHALL INDICATE AN ALARM CONDITION AT THE FMCS WORKSTATION:

- LOW STATIC PRESSURE SWITCH INDICATES RETURN DUCT PRESSURE LESS THAN THE SPECIFIED DUCT PRESSURE CLASS.
- LOW STATIC PRESSURE SWITCH INDICATES MIXED AIR PRESSURE LESS THAN THE SPECIFIED DUCT PRESSURE CLASS OF THE OUTSIDE AIR DUCTWORK.
- HIGH STATIC PRESSURE SWITCH INDICATES SUPPLY DUCT STATIC PRESSURE GREATER THAN THE SPECIFIED DUCT PRESSURE CLASS.
- DUCT SMOKE DETECTOR INDICATES SMOKE IN THE SYSTEM.
- SHOULD THE OUTSIDE AIR DAMPER BE COMMANDED TO CLOSE AND THE DAMPER FEEDBACK INDICATES THE POSITION HAS NOT CHANGED AFTER 30 SECONDS.
- SHOULD ANY ONE FOOT SECTION OF THE MANUAL RESET LOW LIMIT TEMPERATURE SWITCH SENSE AIR TEMP <40°F (ADJ.), IF MULTIPLE FREEZE STATS ARE REQUIRED, LOCATE ADJACENT TO EACH OTHER TO BE RESET BY A COMMON LATCHING RELAY.

THE FOLLOWING CONDITIONS SHALL INDICATE WHICH DEVICE IS IN AN ALARM AT THE FMCS AND SHALL INDICATE WHICH DEVICE IS IN AN ALARM CONDITION, HOWEVER AHU SHALL CONTINUE TO OPERATE:

- AN ALARM IS INDICATED AT ANY SUPPLY FAN VFD OR RETURN FAN VFD.
- DIFFERENTIAL PRESSURE SWITCH ACROSS PRE-FILTER BANK EXCEEDS 0.8 INCHES W.G. (ADJ.)
- SEND AN ALARM TO THE FMCS OPERATOR INTERFACE IF THE SPACE TEMPERATURE IS MORE THAN 10°F (ADJ.) ABOVE OR BELOW SETPOINT.

IN THE EVENT THAT THE AIR HANDLER IS SHUTDOWN AS A RESULT OF A LOW LIMIT TEMPERATURE SWITCH OR OUTSIDE AIR DAMPER FAILURE, THE FOLLOWING SHALL OCCUR:

- HEATING CONTROL VALVE SHALL MODULATE FULLY OPEN TO PREVENT COIL RUPTURE.
- ALL OTHER SHUTDOWN REQUIREMENTS/SEQUENCES SHALL REMAIN.

WHENEVER AHU IS SHUTDOWN THE FOLLOWING SHALL OCCUR:

- THE OUTSIDE AIR DAMPER SHALL FULLY CLOSE AND THE RETURN AIR DAMPER SHALL FULLY OPEN.
- HEATING CONTROL VALVE SHALL REMAIN UNDER CONTROL OF ITS INPUT SENSOR.
- SUPPLY FAN VFDs SHALL BE DE-ENERGIZED.

UNOCCUPIED MODE:
 PROVIDE TIME OF DAY SCHEDULE TO ALLOW AHU TO ENTER UNOCCUPIED MODE PER SCHEDULE. COORDINATE SCHEDULE WITH OWNER.

- THE SUPPLY FANS SHALL CONTINUE RUNNING.
- THE OUTSIDE AIR DAMPER SHALL CLOSE AND THE RETURN AIR DAMPER SHALL OPEN.
- ALL SPACE TEMPERATURES SHALL BE ALLOWED TO VARY +/- 10°F (ADJ.) FROM OCCUPIED SETPOINT.
- FMCS SHALL BEGIN MODULATING THE SUPPLY FAN TO MAINTAIN ROOM SETPOINT.

HEATING OPTIMUM START-UP:

- THIS CYCLE SHALL OVERRIDE THE UNOCCUPIED CYCLE. IF THE SYSTEM WAS OPERATING AS A RESULT OF THE UNOCCUPIED CYCLE, THE SYSTEM SHALL CONTINUE TO OPERATE. THE DDC SYSTEM SHALL DETERMINE THE MINIMUM RUNTIME TO WARM THE SPACES TO THEIR SETPOINT WHEN THE COMPUTED START TIME IS REACHED. THE AIR HANDLING UNIT DISCHARGE AIR TEMPERATURE SHALL BE MAINTAINED AT A SETPOINT OF 85°F (ADJ.). THE SYSTEM SHALL CONTINUE TO OPERATE IN THIS MODE UNTIL ALL TEMPERATURES EXCEED A SETPOINT OF 68°F (ADJ.). AT THAT TIME, THE DDC SYSTEM SHALL SWITCH TO OCCUPIED CONTROL.

GRAPHICAL DISPLAY:
 DISPLAY THE GLOBAL OUTSIDE AIR TEMPERATURE AND HUMIDITY ON AHU GRAPHIC PAGE.

1	ADDENDUM 001	05.06.26
-	100% CD ISSUANCE	03.16.26
NO.	DESCRIPTION	DATE

LIGHTVOX STUDIO PLLC
 602.604.6626
 info@lightvoxstudio.com
 4602 E Thomas Rd Ste 100
 Phoenix AZ 85018

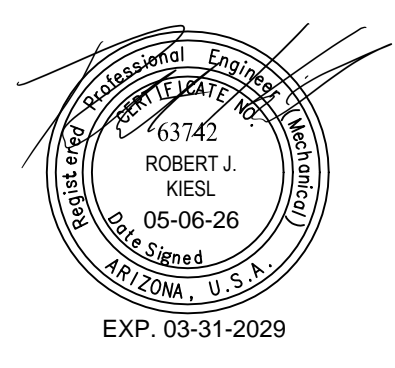

PROJECT:
[FMF] Fieldhouse HVAC Scope

09.300.251
 1050 S KNOLES DR.
 FLAGSTAFF, AZ 86011

MECHANICAL
 CONTROLS

M302

IMEG
 9000 E PIMA CENTER PARKWAY
 SUITE 320
 SCOTTSDALE, AZ 85298
 P: 480.222.3771
 www.imegcorp.com

IMEG RESERVES PROPRIETARY RIGHTS, INCLUDING COPYRIGHTS, TO THIS DRAWING AND THE DATA SHOWN THEREON. SAID DRAWING AND/OR DATA ARE THE EXCLUSIVE PROPERTY OF IMEG AND SHALL NOT BE USED OR REPRODUCED FOR ANY OTHER PROJECT WITHOUT THE EXPRESS WRITTEN APPROVAL AND PARTICIPATION OF IMEG.
 ©2024 IMEG CONSULTANTS CORP.

REF. SCALE IN INCHES: 0 1 2 3
 PROJECT #18003389.00

1 SINGLE ZONE AIR HANDLING UNIT - HV-1
 NO SCALE