

**Fieldhouse HVAC Replacement
NAU Project #09.300.251
Hard Bid Procurement for Construction
Services April 29, 2026**

ADDENDUM #1

PART 1 – GENERAL

- A. Date of Issue: April 29, 2026.
- B. The following Addendum shall be incorporated in the Contract Documents of the above-named job, and all requirements herein are fully a part of the Contract Documents as if included therein.
- C. Offerors shall acknowledge receipt of all Addenda in their Response to the Notice of Bid, on *Form of Bid (FS#1)*. Failure to do so may subject the Offeror to disqualification.

PART 2 – CLARIFICATIONS

- 1. **Question:** Please clarify the schedule of events planned for the Fieldhouse during summer 2027? When will the Fieldhouse be unavailable for construction activities?

Response: *As of April 28, 2026, the Union Fieldhouse has events booked on the dates shown below. The Contractor will need to coordinate construction with these dates in mind. The NAU Project Manager will be able to discuss the schedule in more detail with the successful Bidder.*

June: 29 and 30.

July: 2, 3, 4, 5, 7, 8, 9, 10, 11, 12, 13, 14, 15, 17, 18, 19, 21, 22, 24, 25, 26, and 31.

August: 1, 2, and 7.

- 2. **Question:** Will the new system require glycol? If so, who will be responsible for purchasing and installing the glycol?

Response: *The glycol in the existing system can be drained into barrels and reused. If the Contractor does not do this and new glycol is needed, it must be provided and installed by the Contractor at their cost and in accordance with NAU Technical Standards.*

- 3. **Question:** Will the installation of hot taps or T's be required?

Response: *Hot taps may be required if the new isolation valves and connections are being made into live steam/chilled water mains that cannot be shut down; otherwise a tee cut-in may be used*

with an approved outage. The NAU Technical Standards state that when an existing system hot tap is necessary, a full-port ball valve to isolate the new branch line shall be used. The existing valves have been tested annually. If the existing valves fail when the work is done under this project, a change order to address this will be agreed with the Contractor

4. **Question:** Who will supply the hose kits for the new AHUs? Will the contractor be required to install these?
Response: *Hose kits and any additional items not included in the AHU submittal will need to be provided by the Contractor. The Submittal for the new AHUs is included as ATTACHMENT D with this addendum.*
5. Bidders shall note that the project schedule has been modified. The new schedule of important dates are shown below.

Deadline for Inquiries:	May 1, 2026
Bids Due:	May 7, 2026
Construction Start:	July 6, 2026
Substantial Completion:	September 25, 2026
Final Completion:	December 4, 2026
6. The NAU Hard Bid contract has been updated. It can be found under the “Current Contracts” section of this NAU [webpage](#).
7. NAU has clarified with the AHU vendors (Daikin and MAS) that we will be able to purchase an extended warranty to cover the equipment/parts beyond the initial warranty phase.

PART 3 – ADDENDUM

1. **DELETE** PROJECT SCHEDULE (page 1)

Construction Start:	June 1, 2026
Substantial Completion:	August 7, 2026
Final Completion:	October 30, 2026

ADD PROJECT SCHEDULE (page 1)

Construction Start:	July 6, 2026
Substantial Completion:	September 25, 2026
Final Completion:	December 4, 2026
2. **DELETE** **BID DUE DATE AND SUBMITTAL REQUIREMENTS** (page 2)

Immediately following the **bid submittal deadline of May 1, 2026, at 11:00AM**, the bids will be publicly opened via a MS Teams meeting. Attendance in person by Offerors or the public is not allowed. The weblink to attend the MS Teams meeting is below.

<https://teams.microsoft.com/meet/2706651686466?p=BcUZ3z8wVcdVPioycu>

ADD **BID DUE DATE AND SUBMITTAL REQUIREMENTS** (page 2)

Immediately following the **bid submittal deadline of May 7, 2026, at 11:00AM**, the bids will be publicly opened via an MS Teams meeting. Attendance in person by Offerors or the public is not allowed. The weblink to attend the MS Teams meeting is below.

<https://teams.microsoft.com/meet/2706651686466?p=BcUZ3z8wVcdVPioycu>

3. **DELETE** Form of Bid (FS#1)
- ADD** Form of Bid (FS#1 included with this addendum.
4. **ADD** The Air Handling Units (AHUs) Submittal package is included with this addendum as ATTACHMENT D to the *Notice of Bid*.

REVISED FORM OF BID (FS#1)

FORM OF BID (FS#1)

Fieldhouse HVAC Replacement

NAU PROJECT NO. 09.300.251

The undersigned hereby proposes, and agrees to furnish all labor, material, transportation, supervision and services necessary to complete all work as called for in the plans and specifications, and that the lump sum bid includes all applicable costs of bonds, insurance, permits and fees, and sales tax, or any applicable taxes. **The Owner's selection will be made on a Bid (pre-tax) price per ABOR policy 3-803 A 7. The contract will be issued for the lump sum amount, inclusive of the tax.**

We acknowledge the following addenda and have included their provisions in this proposal.

Addendum No. _____ Dated _____

Addendum No. _____ Dated _____

Addendum No. _____ Dated _____

Addendum No. _____ Dated _____

BASE BID: The undersigned proposes to complete all work as required per the Specifications, for a Lump Sum of (noted below in words and numbers):

Bid (pre-tax): _____ Dollars
(\$ _____).

Taxes: _____ Dollars
(\$ _____).

Cumulative Bid: _____ Dollars
(\$ _____).

Enclosed herewith is a cashier's check or Bid Bond (NAU form FS#9) made payable to the Owner in the amount of \$ _____, which is not less than 10% of the amount of the total bid proposal, as a guarantee that the undersigned will furnish required Performance Bond and Labor and Material Bond, and enter into contract, on basis of above proposal.

Undersigned further agrees that said check (or Bid Bond) shall be forfeited as Liquidated Damages (no penalty) if undersigned fails to enter into contract after requested to do so by Owner.

Bids shown above are valid for a period of 60 days after the date of opening bids, and may be withdrawn following that date if no contract has been awarded.

The undersigned understands that the Owner reserves the right to reject any or all bids, or to waive any informality in receipt of the above Proposal. **Owner reserves the right to award by Base Bid alone, by the sum of Base Bid and any combination of Additive Alternate Amounts, or as the sum of the Base Bid and all the Additive Alternate Amounts, whichever is deemed most advantageous to Owner.**

It is hereby understood and mutually agreed by and between the Contractor and the Owner that the date of beginning, rate of progress, and time of completion of the Work as set forth in the contract documents are of the essence of the contract. The amount of **\$100.00 per calendar day** will be assessed against the contract for work not completed at the Substantial Completion date. Said amounts shall accrue until such time that the Work covered under this contract is complete, not as a penalty, but as Liquidated Damages.

In addition, it is mutually agreed by and between the Contractor and the Owner, the amount of **\$50.00 per calendar day for each phase** will be assessed against the contract for work not completed at the Final Completion date. Said amounts shall accrue until such time that the Work covered under this contract is complete, not as a penalty, but as Liquidated Damages.

The Proposer hereby certifies that he/she is the holder of a valid Contractor's License in accordance with Arizona State Law and that such license classification allows the Contractor to perform the type of construction identified by these Bid Documents. The proposer also certifies that he/she holds all of the required certifications and licenses outlined in the bidding documents and shall provide proof of all certifications, licenses and warranties within 5 days of Owner notification to the apparent low bidder with the Intent to Award.

If corporation,

Company/Corporation

Seal

Signature

Date

Arizona License Class and Number

ATTACHMENT D

AIR HANDLING UNIT (AHU) SUBMITTAL PACKAGE



SUBMITTAL REVIEW COMMENTS

RETURNED TO:

COMPANY: Lightvox Studio
ATTN: Benjamin Mullings
SENT VIA: Email

DATE: 9/23/2024
REVIEWED BY: Rick Ryall

PROJECT NAME: NAU Thermal Storage and Field
PROJECT #: 18003389.00
SECTION NO.: 23 00 00
DESCRIPTION: Air Handling Unit

CONTRACTOR: Varitec Solutions
CTR. SUBMITTAL #: _____
SUBMITTAL DATE: September 23, 2024
DATE RECEIVED: September 23, 2024

This review is only for general conformance with the design concept of the project and general compliance with the information given in the contract documents. Notations made on the shop drawings during this review do not relieve the contractor from compliance with requirements of the contract documents. Approval of a specific item shall not include approval of an assembly of which the item is a component. The contractor is solely responsible for confirming and correlating all quantities and dimensions; selecting fabrication processes and techniques of construction; coordination of his or her work with that of all other trades; and performing all work in a safe and satisfactory manner.

ACTION KEY:

A	APPROVED			
	B	NOTATIONS, NO RESUBMITTAL (REFER TO NOTATIONS)		
		C	REVISE & RESUBMIT (REFER TO NOTATIONS)	
			F	REJECTED (REFER TO NOTATIONS)
			NS	NOT SUBMITTED
				ITEM
				NOTATIONS
	B			FH-1,2; HV-1
				Contractor to confirm handing.

THESE COMMENTS ARE TO BE ATTACHED TO ALL COPIES OF THE SUBMITTAL REFERENCED ABOVE.



AIR HANDLING UNIT SUBMITTAL DATA

PROJECT: NAU Fieldhouse AHU Replacements

LOCATION: Flagstaff, AZ

ENGINEER: IMEG

SUBMITTED BY: Varitec Solutions
2851 W. Kathleen Road
Phoenix, AZ 85053
602-943-1511

MANUFACTURER: Daikin

PRODUCT: Vision Air Handling Units

TAG: FH-1,2 & HV-1

Submittal Date: 9/23/2024
Sales Engineer: Austin Vedder
Prepared by: Austin Vedder

Material List

Project: NAU Fieldhouse AHU Replacements

Equipment: Vision Air Handling Units

Manufacturer: Daikin

Tags: FH-1,2 & HV-1

Daikin Applied Vision™ Indoor Air Handling Units:

- 2" Double Wall Construction w/ R13 Foam Injected Liner & Modified Thermal Break
- Mixing Box w/ Parallel Low Leak Dampers
- 2" MERV 8 Filters
- Chilled Water Cooling Coils w/ Copper Tubes, Aluminum Fins, Galvanized Coil Casings, and SS Drain Pan
- Heating Hot Water Coils w/ Copper Tubes, Aluminum Fins, and Galvanized Coil Casings
- ECM Supply Fan Arrays w/ 100 kAIC Fused Disconnect, Controls Terminal Strip, and HOA switch
- Access Doors Where Required
- 2-Year Parts Warranty
- Factory Authorized Startup

EXCLUSIONS: Installation, Rigging, Storage, Controls, Sensors, Actuators, BMS Integration, Spare Filters, Control Valves, External Vibration Isolation, Smoke Detectors, Labor Warranty, and Anything Not Listed Above.

Job Information		Submittal
Job Name	NAU Ice Rink	
Date	September 23 2024	
Software Version	13.31	
Unit Tag	FH-1,2	

Unit Overview						
Model Number	Air Volume cfm	Supply				
		Static Pressure		External Dimensions		
		External inWc	Total inWc	Height in	Width in	Length in
Daikin Vision	8000	1.00	4.27	50*	72*	148

*Not including base rails, coil connectors, drain connectors and control boxes.

Unit			
Model Number:	Vision		
Outer Panel:	24 gauge G90 Galvanized Steel (unpainted)		
Liner:	24 gauge Galvanized Steel (unless noted per section)		
Insulation:	R-13 Injected Foam		
Unit Configuration:	Inline horizontal	Drive (Handling) Location:	Right
Base:	None	Wall Thickness:	2 in
Altitude:	7000 ft	Parts Warranty:	Additional One Year, Two Year Total

Mixing Box								
Portion	Size (length x width)		Damper			Blade Action	Rated CFM	Quantity
	Overall	Opening	Location	Type	Actuation			
Outside Air	22 in x 68 in	18 in x 58 in	Top	UltraSeal Low Leak	NA	Parallel	8000 cfm	1
Return Air	22 in x 68 in	18 in x 58 in	Bottom	UltraSeal Low Leak	NA	Parallel	8000 cfm	1

Filter Data							
Type	Efficiency	Face Velocity	Face Area	Air Volume	Filter Loading		
Pleated	MERV 8	406 ft/min	19.7 ft²	8000 cfm	Side		
Air Pressure Drop				Number of Filters	Height	Width	Depth
Clean Air	Mean Air	Dirty Air	User Spec				
0.17 inWc	0.59 inWc	1.00 inWc	N/A	2	24 in	24 in	2 in
				1	24 in	20 in	2 in
				2	20 in	24 in	2 in
				1	20 in	20 in	2 in

Door		
Location	Width	Opening
Drive side	26 in	Outward

Pre-Cool Coil

Physical Data	Materials	Internal Fluid
Mode: Cooling	Fin Matl: Aluminum 0.0060 in.	Fluid: Water
Coils/Bank: 1	Tube Matl: Copper 0.016 in.	Ent Fluid Temp: 42 °F
Fin Type: 1/2" 1.25" x 1.083" Waffle	Conn Size: 3 # Conn: 1	GPM: 41.93
Fin Height: 40"		
Fin Length: 59"		
Rows: 8		
Fins/Inch: 12		
Circuiting: 26 Feeds		
Opp End Connections: No		
Dry Weight (ea.): 341 Lbs.		
Turbulators: Yes		
	Airside	Construction
	Airflow: 8,000.0 SCFM	Coil Hand: Right
	Altitude: 7000 ft.	Casing Matl: 16 Ga Galv Steel
	Ent. DB/WB: 63.7 °F / 60 °F	Casing Type: Flanged
	LDB/WB Req'd: 48.3 °F / 48 °F	Connection Matl: Copper
		Connection Type: MPT

Performance

Description	UOM	Water Perf.
Model		CWG08C12-40.00x59.00R
Rows/FPI	fpi	8 / 12.0
Total Capacity	MBH	294.8
Sensible Capacity	MBH	133.3
Lvg Air DB/WB	°F	48.6 / 48.6
Condensate Rate	Lb/Hr	115.1
Face Velocity	Sfpm	488.14
Lvg Fluid Temp	°F	56.1
Fluid Flow Rate	GPM	41.93
Air Pressure Drop	in. H2O	0.88
Fluid Pressure Drop	Ft. H2O	17.69
Coil Circuiting		Optimized at (26 Feeds) / 18 Pass
Connection Size	NPS	3"
Fluid Velocity	fps	2.93
Dry/Operating Weight (ea.)	Lbs	341 / 469
Internal Volume (ea.)	Gal	15.38

Door		
Location	Width	Opening
Drive side	14 in	Outward

Post-Cool Coil

Physical Data	Materials	Internal Fluid
Mode: Cooling	Fin Matl: Aluminum 0.0075 in.	Fluid: EthyleneGlycol 40 %
Coils/Bank: 1	Tube Matl: Copper 0.016 in.	Ent Fluid Temp: 33 °F
Fin Type: 1/2" 1.25" x 1.083" Waffle	Conn Size: 3 # Conn: 1	GPM: 84.13
Fin Height: 40"		
Fin Length: 59"	Airside	Construction
Rows: 10	Airflow: 8,000.0 SCFM	Coil Hand: Right
Fins/Inch: 13	Altitude: 7000 ft.	Casing Matl: 16 Ga Galv Steel
Circuiting: 63 Feeds	Ent. DB/WB: 48.6 °F / 48.6 °F	Casing Type: Flanged
Opp End Connections: No	LDB/WB Req'd: 38 °F / 37.7 °F	Connection Matl: Copper
Dry Weight (ea.): 463 Lbs.		Connection Type: MPT
Turbulators: Yes		

Performance

Description	UOM	Water Perf.
Model		CWG10C13-40.00x59.00R
Rows/FPI	fpi	10 / 13.0
Total Capacity	MBH	221.9
Sensible Capacity	MBH	95.5
Lvg Air DB/WB	°F	37.7 / 37.7
Condensate Rate	Lb/Hr	93.4
Face Velocity	Sfpm	488.14
Lvg Fluid Temp	°F	39.1
Fluid Flow Rate	GPM	84.13
Air Pressure Drop	in. H2O	1.24
Fluid Pressure Drop	Ft. H2O	9.83
Coil Circuiting		Optimized at (63 Feeds) / 10 Pass
Connection Size	NPS	3"
Fluid Velocity	fps	2.46
Dry/Operating Weight (ea.)	Lbs	463 / 630
Internal Volume (ea.)	Gal	18.71

Door		
Location	Width	Opening
Drive side	14 in	Outward

Hot Water Coil							
Coil Model	Total Capacity	Number of Coils	Number of Rows	Fins per Inch	Tube Diameter	Tube Spacing (Face x Row)	
5WQ1103B	396317 Btu/hr	1	3	11	0.625 in	1.50 in x 1.299 in	
Air Volume	Air Temperature		Coil Air Pressure Drop	Finned Height	Finned Length	Face Area	Face Velocity
	Entering	Leaving					
	Dry Bulb	Dry Bulb					
8000 cfm	38.0 °F	96.8 °F	0.26 inWc	39 in	59 in	15.98 ft ²	501 ft/min
Water		Flow Rate	Pressure Drop	Velocity	Volume	Weight	
Entering	Leaving						
140.0 °F	98.8 °F	19.20 gpm	6.60 ftHd	2.90 ft/s	7.0 gal	65.00 lb	
Connection [Data Per Coil]				Min. Fin Surface Temp.	Min. Tube Wall Surface Temp.	Fouling Factor	
Type	Size	Location	Material				
Threaded	2.00 in	Drive side	Carbon steel	98.8 °F	98.8 °F	0.000	
Material							
Fin	Tube	Header	Case				
Aluminum .0075 in	Copper .020 in	Copper	Galv. steel				
AHRI 410 Certification							
	Certified in accordance with the AHRI Forced-Circulation Air-Cooling and Air-Heating Coils Certification Program which is based on AHRI Standard 410 within the Range of Standard Rating Conditions listed in Table 1 of the Standard. Certified units may be found in the AHRI Directory at www.ahridirectory.org						
Panel							
Location	Width	Opening					
Removable panels	- in	Outward					

ECM Fan Array						
Fan Data						
Air Volume (each/total)	Total Static Pressure	Quantity of Fans	Input Power (each)	Operating RPM	Material	Fan Weight (each)
4000/8000 CFM	4.27 inWC	2	4.31 HP	2168 rpm	HP Composite	93 lb
Fan Model	Efficiency	Redundancy	Array Weight			
116177/A01	62.36 %	71 %	407 lb			
Motor/Electrical Data						
Motor Horsepower (each)	Maximum RPM	Electrical Supply	Full Load Current (each)	MCA	MOCP	
6.97 HP	2570 rpm	460 V/3ph	6.96 A	15.66 A	20 A	
Fan Options						
Blank-Off Plate:	Included		Isolation Backdraft Dampers:		None	
Fan Panel Disconnect:	100kAIC Fused Disconnect		Control Input:		0-10 VDC	

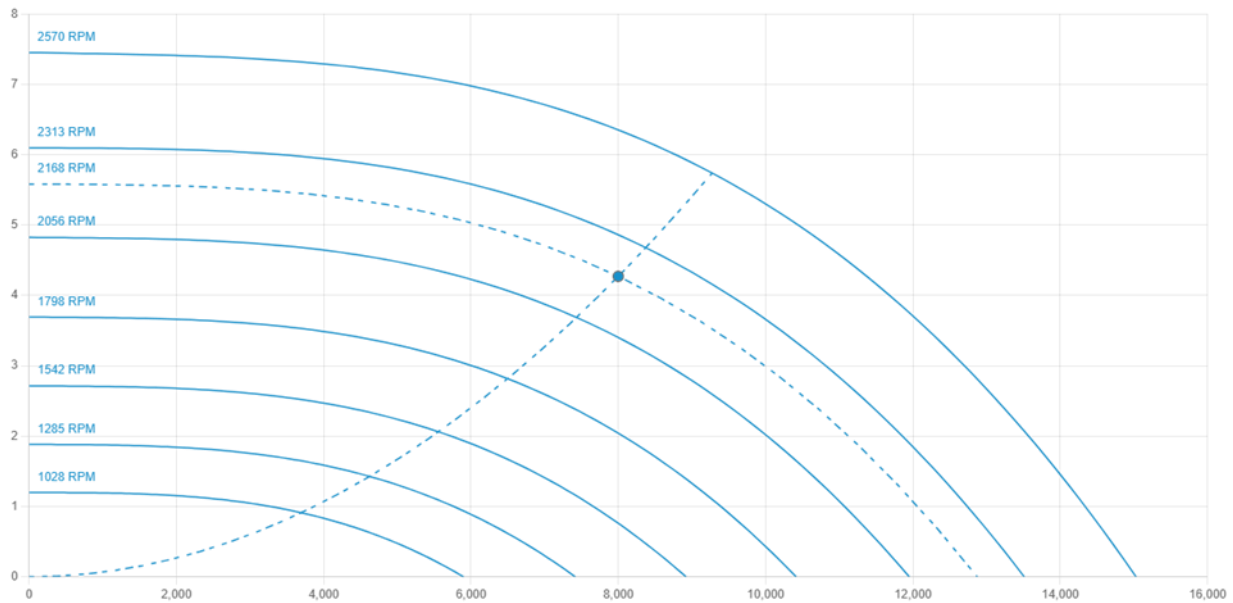

Array Sound Power (dB)								
Type	63 Hz	125 Hz	250 Hz	500 Hz	1000 Hz	2000 Hz	4000 Hz	8000 Hz
Radiated:	69	68	66	60	60	53	46	51
Unit Discharge:	79	78	84	81	82	81	76	72
Unit Return:	76	73	79	76	72	69	65	65

Access Section		
Door		
Location	Width	Opening
Drive side	24 in	Outward

Shipping Section Details

Section	Length in	Weight lb	Corner Weights (lb)				Center of Gravity (in)		
			P1	P2	P3	P4	XX	YY	ZZ
1	120	2825	677	497	697	948	70	31	22
2	28	746	252	156	167	270	14	27	25
Entire Unit	148	3571	916	647	870	1232	85	30	24

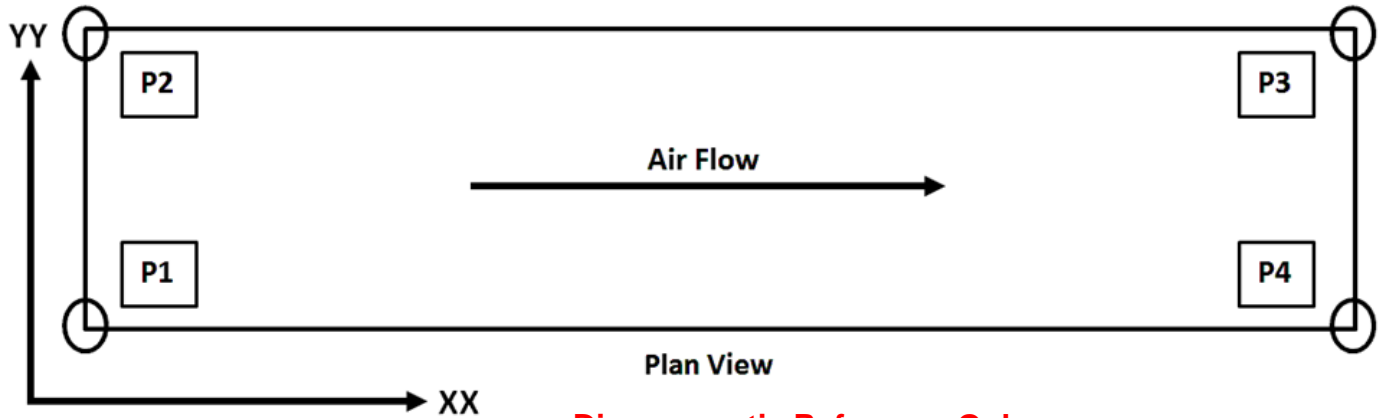

Diagrammatic Reference Only

Point Loading Locations Typical for Both Sections

Unit Layout

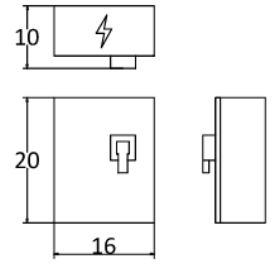
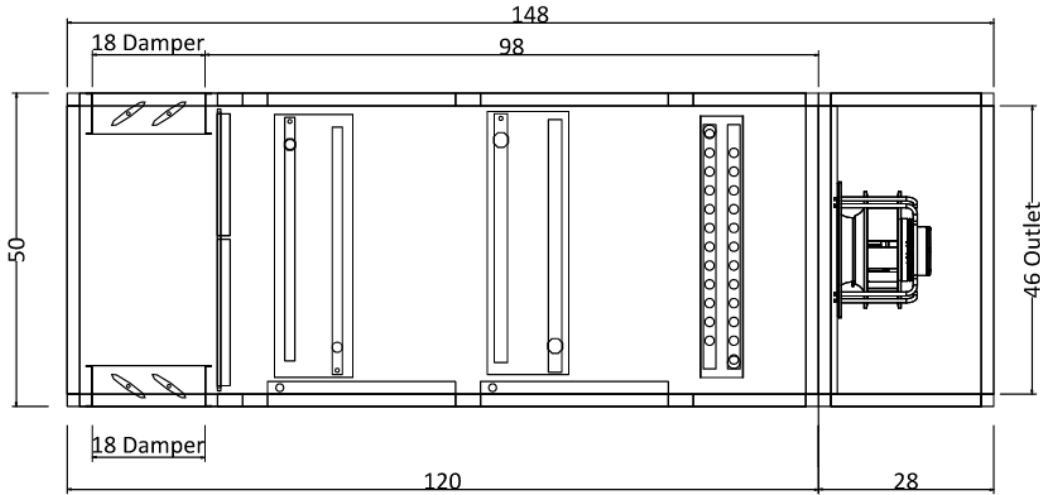
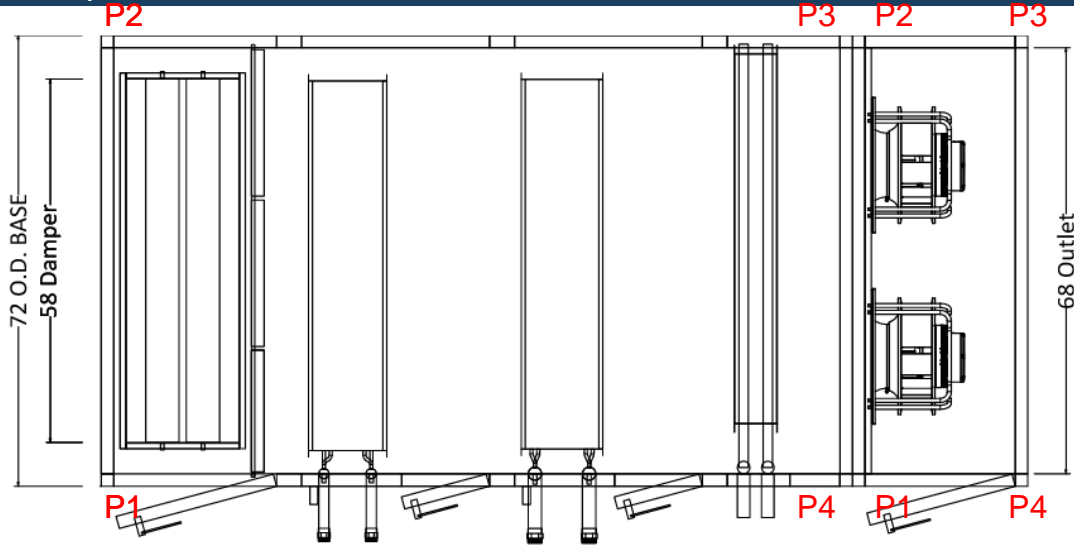

Single point power panel to be field mounted and wired

Job Information		Submittal
Job Name	NAU Fieldhouse AHU Replacements	
Date	September 9 2024	
Software Version	13.42	
Unit Tag	HV-1	

Unit Overview						
Model Number	Air Volume cfm	Supply				
		Static Pressure		External Dimensions		
		External inWc	Total inWc	Height in	Width in	Length in
Daikin Vision	13500	0.30	2.50	36*	92*	112

*Not including base rails, coil connectors, drain connectors and control boxes.

Unit			
Model Number:	Vision		
Outer Panel:	24 gauge G90 Galvanized Steel (unpainted)		
Liner:	24 gauge Galvanized Steel (unless noted per section)		
Insulation:	R-13 Injected Foam		
Unit Configuration:	Inline horizontal	Drive (Handling) Location:	Right
Base:	None	Wall Thickness:	2 in
Altitude:	7000 ft	Parts Warranty:	Additional One Year, Two Year Total

Mixing Box								
Portion	Size (length x width)		Damper			Blade Action	Rated CFM	Quantity
	Overall	Opening	Location	Type	Actuation			
Outside Air	22 in x 88 in	18 in x 78 in	Top	UltraSeal Low Leak	NA	Parallel	13500 cfm	1
Return Air	22 in x 88 in	18 in x 78 in	Bottom	UltraSeal Low Leak	NA	Parallel	13500 cfm	1

Filter Data							
Type	Efficiency	Face Velocity	Face Area	Air Volume	Filter Loading		
Pleated	MERV 8	486 ft/min	27.8 ft²	13500 cfm	Side		
Air Pressure Drop				Number of Filters	Height	Width	Depth
Clean Air	Mean Air	Dirty Air	User Spec				
0.22 inWc	0.61 inWc	1.00 inWc	N/A	4	24 in	24 in	2 in
				4	24 in	20 in	2 in

Door		
Location	Width	Opening
Drive side	26 in	Outward

Hot Water Coil							
Coil Model	Total Capacity	Number of Coils	Number of Rows	Fins per Inch	Tube Diameter	Tube Spacing (Face x Row)	
5WL1104B	971703 Btu/hr	1	4	11	0.625 in	1.50 in x 1.299 in	
Air Volume	Air Temperature		Coil Air Pressure Drop	Finned Height	Finned Length	Face Area	Face Velocity
	Entering	Leaving					
	Dry Bulb	Dry Bulb					
13500 cfm	0.0 °F	85.4 °F	0.93 inWc	27 in	79 in	14.81 ft ²	911 ft/min
Water		Flow Rate	Pressure Drop	Velocity	Volume	Weight	
Entering	Leaving	48.40 gpm	6.20 ftHd	3.70 ft/s	8.0 gal	71.00 lb	
140.0 °F	99.8 °F						
Connection [Data Per Coil]				Min. Fin Surface Temp.	Min. Tube Wall Surface Temp.	Fouling Factor	
Type	Size	Location	Material				
Threaded	2.00 in	Drive side	Carbon steel	99.8 °F	99.8 °F	0.000	
Material							
Fin		Tube		Header		Case	
Aluminum .0075 in		Copper .020 in		Copper		Galv. steel	
AHRI 410 Certification							
		Certified in accordance with the AHRI Forced-Circulation Air-Cooling and Air-Heating Coils Certification Program which is based on AHRI Standard 410 within the Range of Standard Rating Conditions listed in Table 1 of the Standard. Certified units may be found in the AHRI Directory at www.ahridirectory.org					
Door							
Location			Width			Opening	
Drive side			16 in			Outward	

ECM Fan Array						
Fan Data						
Air Volume (each/total)	Total Static Pressure	Quantity of Fans	Input Power (each)	Operating RPM	Material	Fan Weight (each)
4500/13500 CFM	2.50 inWC	3	3.13 HP	1947 rpm	HP Composite	93 lb
Fan Model	Efficiency	Redundancy	Array Weight			
116177/A01	56.65 %	97 %	492 lb			
Motor/Electrical Data						
Motor Horsepower (each)	Maximum RPM	Electrical Supply	Full Load Current (each)	MCA	MOCP	
6.97 HP	2570 rpm	460 V/3ph	6.96 A	22.62 A	25 A	
Fan Options						
Blank-Off Plate:	Included		Isolation Backdraft Dampers:			None
Fan Panel Disconnect:	100kAIC Fused Disconnect		Control Input:			0-10 VDC

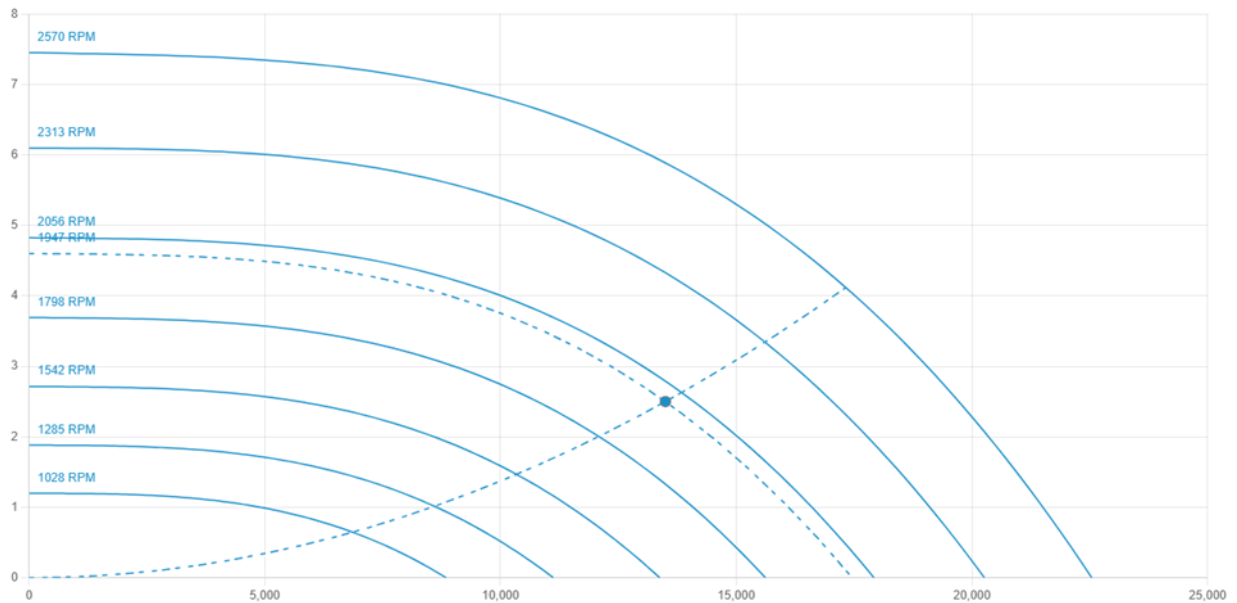

Type	Array Sound Power (dB)							
	63 Hz	125 Hz	250 Hz	500 Hz	1000 Hz	2000 Hz	4000 Hz	8000 Hz
Radiated:	67	68	67	61	60	52	46	51
Unit Discharge:	77	78	85	82	82	80	76	75
Unit Return:	75	74	80	77	72	69	65	69

Plenum Section				
Custom Opening	Location	Width	Height	Rainhood w/Screen
1	End	88 in	32 in	None
Door				
Location	Width	Opening		
Drive side	30 in	Outward		

Shipping Section Details

Section	Length in	Weight lb	Corner Weights (lb)				Center of Gravity (in)		
			P1	P2	P3	P4	XX	YY	ZZ
1	78	1033	237	228	279	288	43	45	18
2	34	715	335	176	156	297	16	32	18
Entire Unit	112	1748	459	333	506	698	68	39	18

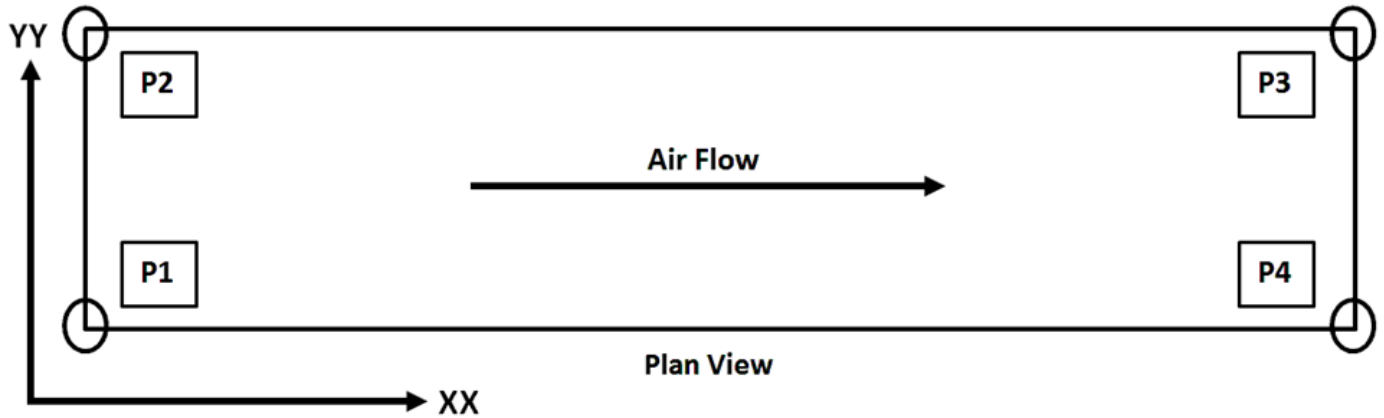

Diagrammatic Reference Only

Point Loading Locations Typical for Both Sections

Unit Layout

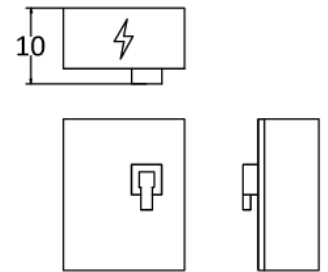
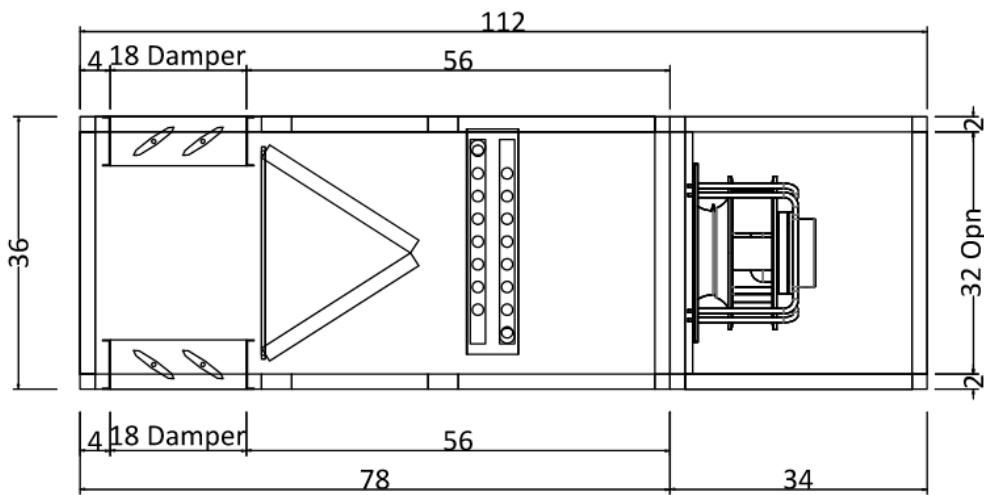
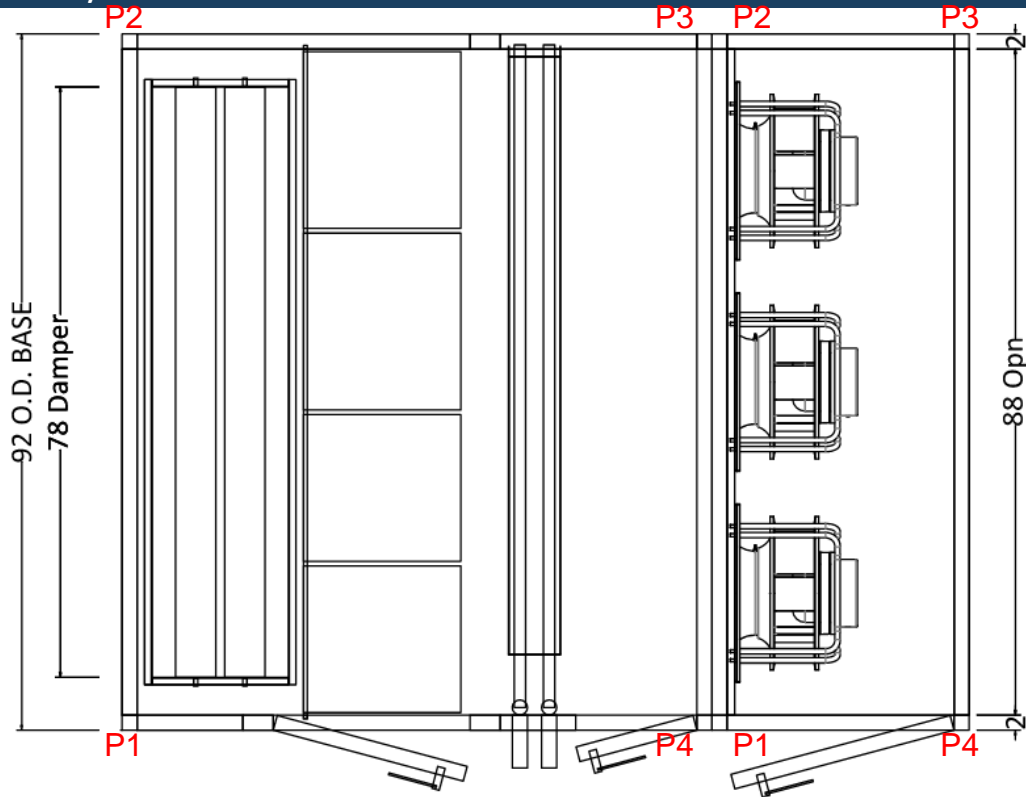

Single point power panel to be field mounted and wired

END OF ADDENDUM #1