

DIVISION 8 – OPENINGS

Section Number	Title
08 00 00	OPENINGS
08 10 00	DOORS AND FRAMES
08 11 00	Metal Doors and Frames
08 11 13	Hollow Metal Doors and Frames
08 11 19	Stainless-Steel Doors and Frames
08 14 00	Wood Doors
08 17 00	Integrated Door Opening Assemblies
08 40 00	ENTRANCES, STOREFRONTS, AND CURTAIN WALLS
08 41 00	Entrances and Storefronts
08 41 13	Aluminum-Framed Entrances and Storefronts
08 41 23	Steel-Framed Entrances and Storefronts
08 42 00	Entrances
08 42 29	Automatic Entrances
08 44 00	Curtain Wall and Glazed Assemblies
08 50 00	WINDOWS
08 51 00	Metal Windows
08 52 00	Wood Windows
08 52 16	Plastic-Clad Wood Windows
08 70 00	HARDWARE
08 80 00	GLAZING
08 81 00	Glass Glazing

DIVISION 8 – OPENINGS

Section Number	Title
08 00 00	OPENINGS

GENERAL INFORMATION

Doors and door hardware are to be installed only by qualified persons and all work must meet codes referenced in Division 1. No exceptions will be made to the hardware listed below for use in any University construction without prior testing, evaluation and approval by appropriate departments within Facility Services (FS).

All doors, hardware, openers, etc. shall be specified as institutional grade throughout.

Final acceptance of any hardware installations shall be subject to approval by the Facility Services, Building Access Services Department.

All hardware submittals shall be routed through the Building Access Services Department for review and approval prior to purchase.

08 10 00 DOORS AND FRAMES

08 11 00 Metal Doors and Frames

08 11 13 Hollow Metal Doors and Frames

General

This section applies to both interior and exterior applications. In general, hollow metal doors should be designed and specified for areas of heavy use and potential abuse. Commercial heavy duty hollow metal frames should be utilized regardless of whether the door be hollow metal, glass, or wood.

08 11 19 Stainless-Steel Doors and Frames

General

Doors and frames shall be specified as commercial heavy duty quality. Minimum door thickness shall be 1-3/4" thick. Interior doors shall comply with SD1-100, Grade II, heavy duty, minimum 16 gauge faces. Exterior doors shall comply with SD1-100 Grade III extra heavy duty, minimum 16 gauge faces.

All exterior doors shall have thresholds, closures, weatherstripping, and padded stops.

Designs calling for exterior glazed openings in steel doors shall use 1" insulated wire glass. Openings shall be limited to less than 60% glass area (code permitting).

At least one section of an exterior door assembly (main ingress and egress) shall have an electric automatic door opener, button activated on both sides, interior and exterior Kickplates are required of all doors that are subject to high traffic.

DIVISION 8 – OPENINGS

Section
Number

Title

Door Frames

In new construction all frames shall be specified as welded. Knock-downs may be acceptable in building renovation work, pending FS Building Access Services approval of submittals and final installation. An inspection of anchoring must be made prior to drywall or closing up of walls.

Frames shall have wall anchors a maximum of 16" o.c. per jamb. All door frames will be steel. Exterior door frames will be 14 gauge and protected from rust, internal frames may also be 14 gauge steel.

Door frames shall be factory pre-assembled with mitered fully welded joints ground smooth and delivered to the job site with spreaders. If knock-down and two-piece frames are unavoidable and approved in advanced by FS Building Access Services, specification must require quality standards for securing and finishing these frames. Shop priming is required.

All frames shall be delivered prior to masonry construction. All frames in masonry walls shall be grouted full with Portland cement grout. Gypsum grout is not permitted.

Specify seamless end channel closure pieces at door heads.

Doors

All external doors will be 16 gauge steel with vertical steel rib stiffeners and reinforced for all door hardware. Internal doors shall be 16 gauge, or may be solid core wood.

Where doors are to be used as part of an acoustical barrier assembly, they shall be rated a minimum of STC 33.

Doors used as a normal means of ingress and egress shall have either vision panels or adjacent sidelights (where allowable by fire ratings).

Doors shall have a minimum of 3 heavy duty industrial type hinges per door. (see 08 70 00)

Doors and frames shall have a spray applied finish.

DP shall specify door stops on all installations, closures if doors open into a rated space.

DIVISION 8 – OPENINGS

Section
Number
08 14 00

Title
Wood Doors
General

This section applies to interior applications. Endangered or limited tree species are not allowable for wood door veneers. Doors receiving painted finishes should be limited to low cost species (birch, maple, etc.). Welded hollow metal frames should be utilized.

Wooden doors are acceptable only for interior usage, must be solid core, and have adhesives that are 100% waterproof. Hollow core doors shall not be specified and existing hollow core doors shall not be re-used.

All doors shall be solid core flush with veneer faces, commercial heavy duty minimum grade, 1-3/4" thick. Minimum width to be 3'-0". Maximum height to be 7'-0". **3'0" x 7'0" doors are the University's standard. Exceptions must be reviewed and approved by FS Building Access Systems. Specified requirements for non-standard doors are available through carpentry shop if approval is granted.**

Doors for renovation work shall be drilled to match existing handle-set elevations.

All doors should be specified from a single manufacturer.

Specify formaldehyde off-gassing rates to be less than .03 milligrams per square foot of surface/hr in accordance with ASTM D5116-90.

Doors shall carry a life of installation warranty from the manufacturer. All doors that are warped, after installation, shall be replaced prior to substantial completion. Substantial completion cannot be achieved if one hour rated corridors integrity is compromised by warped doors.

Where doors are to be used as part of an acoustical barrier assembly, they shall be rated a minimum of STC 33.

Door receiving a stained finish shall be specified as having premium quality face veneers, minimum thickness 1/16". Doors receiving a paint finish shall be smooth, faux wood grain, or pre-primed skin.

Doors used as a normal means of ingress and egress shall have either vision panels or adjacent sidelights (where allowable by code) in metal frames.

Doors shall have a minimum of 3 heavy duty type hinges per door.

DIVISION 8 – OPENINGS

**Section
Number**

Title

Doors and frames shall have a spray applied finish where specified.

All doors subject to heavy traffic shall have kickplates both sides.

Inspection

The contractor is required to have NAU carpentry sign off for door installation after doors and jams have been installed and prior to casing installation. Failure to have sign off will require the contractor to remove the casing for inspection at contractor's expense.

Wood frame pre-hung doors installed in renovations to existing buildings

All pre-hung interior door assemblies shall be inspected after hanging, and before the casing is applied. Assemblies which do not meet specifications shall be re-hung and re-inspected before casing is applied.

All paint grade doors shall be pre-primed.

Doors must be standard sizes whenever possible (ie: 6'-8" tall, 2'-0", 2'-4", 2'-6", 2'-8" or 3'-0" wide)

Installation

All pre-hung door assemblies shall be fastened to the framing with a minimum of 5 groups of 2, 2 ½" nails on both hinge and jamb sides.

Both Jamb and hinge sides will use a minimum of three shimmed contact points.

One screw per hinge will penetrate the rough opening framing by at least 1"

Hinge, Jamb, and head legs of the pre-hung assembly will be straight to within 1/8" deviation along their total length.

Hinge and Jamb legs will be installed to within 1/8" of plumb.

Closed doors shall show a reveal of 1/8" on all three sides of the jamb unit, and ½" to ¾" above the finished flooring.

Doors shall open, close, and latch without excessive force.

Closet door hardware

When closet door ball catches are used, they shall be Grainger model 1VZX5C or equivalent.

DIVISION 8 – OPENINGS

Section Number	Title
08 17 00	Integrated Door Opening Assemblies

Smoke and draft assemblies shall comply with IBC and IFC (or the most current building and fire codes).

DIVISION 8 – OPENINGS

Section Number	Title
08 40 00	ENTRANCES, STOREFRONTS, AND CURTAIN WALLS
08 41 00	Entrances and Storefronts
08 41 13	<p>Aluminum-Framed Entrances and Storefronts</p> <p>Aluminum entrances and storefronts shall pass water leak testing prior to substantial completion and prior to payment for materials and labor. Test area shall include perimeter caulk joint. All failed windows shall be retested until they pass. All retesting and associated costs shall be paid for by the contractor, via deduct change order.</p> <p>All window openings shall be thermal broke, sill flashed to exterior, and flashing end dammed. All exterior glass shall be insulating glass, except vestibule doors and windows.</p> <p>Bottom of window rough opening shall be a minimum of 12" above grade, slabs on grade, or other horizontal surfaces.</p> <p>Glass manufacturer shall provide a written warranty that shall guarantee insulating glass units for a period of ten years.</p> <p>Aluminum entrance section hardware shall meet all requirements in section 08 41 13. Weatherstripping for exterior doors shall be continuous at head, jambs, and door bottoms.</p> <p>All aluminum doors will be wide stile with a mid-rail.</p>
08 41 23	<p>Steel-Framed Entrances and Storefronts</p> <p>Steel entrances and storefronts shall pass water leak testing prior to substantial completion and prior to payment for materials and labor. Test area shall include perimeter caulk joint. All failed windows shall be retested until they pass. All retesting and associated costs shall be paid for by the contractor, via deduct change order.</p> <p>All window openings shall be thermal broke, sill flashed to exterior, and flashing end dammed. All exterior glass shall be insulating glass, except vestibule doors and windows.</p> <p>Glass manufacturer shall provide a written warranty that shall guarantee insulating glass units for a period of ten years.</p> <p>Steel entrance section hardware shall meet all requirements in section 08 41 23. Weatherstripping for exterior doors shall be continuous at head, jambs, and door bottoms.</p>
08 42 00	Entrances

DIVISION 8 – OPENINGS

Section Number	Title
08 42 29	<p>Automatic Entrances</p> <p>All automatic entrance doors shall comply with all door and hardware specifications contained in Division 8.</p> <p>Entrance doors shall pass water leak testing prior to substantial completion and prior to payment for materials and labor. Test area shall include perimeter caulk joint. All retesting and associated costs shall be paid for by the contractor, via deduct change order.</p> <p>Glass manufacturer shall provide a written warranty that shall guarantee insulating glass units for a period of ten years.</p> <p>Hardware shall meet all requirements in section 08 70 00. Weatherstripping for exterior doors shall be continuous at head, jambs, and door bottoms.</p>
08 44 00	<p>Curtain Wall and Glazed Assemblies</p> <p><u>General</u></p> <p>This section applies to exterior glazed curtain wall systems and storefronts (also used as fixed window systems). Curtain wall systems should be avoided on east and west exposures.</p> <p>The DP shall specify that a fabricator/erector shall have a minimum of 5 years of experience of similar size and scope in the fabrication and erection of systems specified in the project.</p> <p>Curtain wall systems shall utilize 1", dual pane insulated glass, fully tempered.</p> <p>Steel or hollow metal type system shall be specified. Aluminum alloy extrusions are not acceptable in areas that support or are directly adjacent to door openings.</p> <p>"Kynar 500" or equal shall be specified for painted finishes, spray applied.</p> <p>Water penetration shall not occur at a test pressure of 7.00 psf when tested in accordance to ASTM E 331.</p> <p>Entrances and storefronts shall pass water leak testing prior to substantial completion and prior to payment for materials and labor. Test area shall include perimeter caulk joint. All failed windows shall be retested until they pass. All retesting and associated costs shall be paid for by the contractor, via deduct change order.</p> <p>Bottom of window rough opening shall be a minimum of 12" above grade, slabs</p>

DIVISION 8 – OPENINGS

**Section
Number**

Title

on grade, or other horizontal surfaces.

Glass manufacturer shall provide a written warranty that shall guarantee insulating glass units for a period of ten years.

Maximum air infiltration shall not exceed 0.05 cfm per gross square foot of exterior area, when tested in accordance with ASTM E 283, section 4.3.

Where doors are utilized in curtain wall assemblies, at least one section of an exterior door assembly (main ingress and egress) shall have an electric automatic door opener, button activated at the swing side, interior and exterior.

In areas where the interior clear height of curtain walls exceed 30' (possibly an atrium) an interior system(s) must be designed to facilitate window washing without the use of erected scaffolding or movable lifts. On buildings that exceed 3 stories or 40' from finish grade, an exterior window washing system shall be designed.

DIVISION 8 – OPENINGS

Section Number	Title
08 50 00	WINDOWS
08 51 00	Metal Windows <p>Aluminum or any other type of metal sash windows shall have thermal breaks, sill flashed to the exterior, and flashing end dammed. All exterior glass shall be insulating glass.</p> <p>Glass manufacturer shall provide a written warranty that shall guarantee insulating glass units for a period of ten years.</p> <p>All windows shall pass water leak testing prior to substantial completion and prior to payment for materials and labor.</p> <p>Test area shall include perimeter caulk joint. All failed windows shall be retested until they pass. All retesting and associated costs shall be paid for by the contractor, via deduct change order.</p>
08 52 00	Wood Windows
08 52 16	Plastic-Clad Wood Windows <p>Vinyl clad wooden windows are the preferred specified product. All exterior glass shall be insulating glass.</p> <p>Glass manufacturer shall provide a written warranty that shall guarantee insulating glass units for a period of ten years.</p> <p>All windows shall pass water leak testing prior to substantial completion and prior to payment for materials and labor. Test area shall include perimeter caulk joint. All failed windows shall be retested until they pass. All retesting and associated costs shall be paid for by the contractor, via deduct change order.</p>

DIVISION 8 – OPENINGS

Section Number	Title
08 70 00	HARDWARE

PART 1 - GENERAL

1.1 RELATED DOCUMENTS

- A. Drawings and general provisions of the Contract, including General and Supplementary Conditions and Division 01 Specification Sections, apply to this Section.

1.2 SUMMARY

A. Section includes:

1. Mechanical door hardware for the following:
 - a. Swinging doors.
 - b. Sliding doors.
2. Cylinders for door hardware specified in other Sections.
3. Electrified door hardware.

B. Related Sections:

1. Section 08 11 13 "Hollow Metal Doors and Frames" for astragals provided as part of labeled fire-rated assemblies and for door silencers provided as part of hollow-metal frames.
2. Section 08 41 13 "Aluminum-Framed Entrances and Storefronts" for door silencers provided as part of aluminum frames.
3. Section 08 10 00 "Doors and Frames" for access door hardware, except cylinders.
4. Section 08 70 00, 2.16 "Overhead Stops and Holders" for door hardware provided as part of overhead door assemblies.
5. Section 10 22 13 "Wire Mesh Partitions" for door hardware for doors in wire mesh partitions, except cylinders.

1.3 ACTION SUBMITTALS

- A. Product Data: For each type of product indicated. Include construction and installation details, material descriptions, dimensions of individual components and profiles, and finishes.

- B. Shop Drawings: Details of electrified door hardware, indicating the following:

1. Wiring Diagrams: For power, signal, and control wiring and including the following:
 - a. Details of interface of electrified door hardware and building safety and security systems.
 - b. Schematic diagram of systems that interface with electrified door hardware.
 - c. Point-to-point wiring.
 - d. Risers.
 - e. Elevations doors controlled by electrified door hardware.
2. Operation Narrative: Describe the operation of doors controlled by electrified door hardware.

DIVISION 8 – OPENINGS

Section Number	Title
C.	Other Action Submittals:
1.	Door Hardware Schedule: Prepared by or under the supervision of Installer, detailing fabrication and assembly of door hardware, as well as installation procedures and diagrams. Coordinate final door hardware schedule with doors, frames, and related work to ensure proper size, thickness, hand, function, and finish of door hardware.
a.	Submittal Sequence: Submit door hardware schedule concurrent with submissions of Product Data, Samples, and Shop Drawings. Coordinate submission of door hardware schedule with scheduling requirements of other work to facilitate the fabrication of other work that is critical in Project construction schedule.
b.	Format: Comply with scheduling sequence and vertical format in DHI's "Sequence and Format for the Hardware Schedule." Double space entries, and number and date each page.
c.	Format: Use same scheduling sequence and format and use same door numbers as in the Contract Documents.
d.	Content: Include the following information: <ol style="list-style-type: none">1) Identification number, location, hand, fire rating, size, and material of each door and frame.2) Locations of each door hardware set, cross-referenced to Drawings on floor plans and to door and frame schedule.3) Complete designations, including name and manufacturer, type, style, function, size, quantity, function, and finish of each door hardware product.4) Description of electrified door hardware sequences of operation and interfaces with other building control systems.5) Fastenings and other pertinent information.6) Explanation of abbreviations, symbols, and codes contained in schedule.7) Mounting locations for door hardware.8) List of related door devices specified in other Sections for each door and frame.
2.	Keying Schedule: Prepared by or under the supervision of Installer, detailing Owner's final keying instructions for locks. Include schematic keying diagram and index each key set to unique door designations that are coordinated with the Contract Documents.
1.4	INFORMATIONAL SUBMITTALS
A.	Qualification Data: For Installer.
B.	Product Certificates: For electrified door hardware, from the manufacturer.
1.	Certify that door hardware approved for use on types and sizes of labeled fire-rated doors complies with listed fire-rated door assemblies.

DIVISION 8 – OPENINGS

Section Number	Title
	C. Product Test Reports: For compliance with accessibility requirements, based on evaluation of comprehensive tests performed by manufacturer and witnessed by a qualified testing agency, for door hardware on doors located in accessible routes.
1.5	CLOSEOUT SUBMITTALS
	A. Maintenance Data: For each type of door hardware to include in maintenance manuals. Include final hardware and keying schedule.
1.6	QUALITY ASSURANCE
	A. Installer Qualifications: Supplier of products and an employer of workers trained and approved by product manufacturers and an Architectural Hardware Consultant who is available during the course of the Work to consult with Contractor, Architect, and Owner about door hardware and keying. <ol style="list-style-type: none">1. Warehousing Facilities: In Project's vicinity.2. Scheduling Responsibility: Preparation of door hardware and keying schedules.3. Engineering Responsibility: Preparation of data for electrified door hardware, including Shop Drawings, based on testing and engineering analysis of manufacturer's standard units in assemblies similar to those indicated for this Project.
	B. Architectural Hardware Consultant Qualifications: A person who is experienced in providing consulting services for door hardware installations that are comparable in material, design, and extent to that indicated for this Project and who is currently certified by DHI as follows: <ol style="list-style-type: none">1. For door hardware, an Architectural Hardware Consultant (AHC).
	C. Source Limitations: Obtain each type of door hardware from a single manufacturer. <ol style="list-style-type: none">1. Provide electrified door hardware from same manufacturer as mechanical door hardware, unless otherwise indicated. Manufacturers that perform electrical modifications and that are listed by a testing and inspecting agency acceptable to authorities having jurisdiction are acceptable.
	D. Fire-Rated Door Assemblies: Where fire-rated door assemblies are indicated, provide door hardware rated for use in assemblies complying with NFPA 80 that are listed and labeled by a qualified testing agency, for fire-protection ratings indicated, based on testing at positive pressure according to NFPA 252 or UL 10C, unless otherwise indicated.
	E. Smoke- and Draft-Control Door Assemblies: Where smoke- and draft-control door assemblies are required, provide door hardware that meet requirements of assemblies tested according to UL 1784 and installed in compliance with NFPA 105. <ol style="list-style-type: none">1. Air Leakage Rate: Maximum air leakage of 0.3 cfm/sq. ft. at the tested pressure differential of 0.3-inch wg of water.

DIVISION 8 – OPENINGS

- | Section Number | Title |
|----------------|--|
| F. | Electrified Door Hardware: Listed and labeled as defined in NFPA 70, Article 100, by a testing agency acceptable to authorities having jurisdiction. |
| G. | Means of Egress Doors: Latches do not require more than 15 lbf to release the latch. Locks do not require use of a key, tool, or special knowledge for operation. |
| H. | Accessibility Requirements: For door hardware on doors in an accessible route, comply with the U.S. Architectural & Transportation Barriers Compliance Board's ADA-ABA Accessibility Guidelines. <ol style="list-style-type: none">1. Provide operating devices that do not require tight grasping, pinching, or twisting of the wrist and that operate with a force of not more than 5 lbf.2. Comply with the following maximum opening-force requirements:<ol style="list-style-type: none">a. Interior, Non-Fire-Rated Hinged Doors: 5 lbf applied perpendicular to door.b. Fire Doors: Minimum opening force allowable by authorities having jurisdiction.3. Bevel raised thresholds with a slope of not more than 1:2. Provide thresholds not more than 1/2 inch high.4. Adjust door closer sweep periods so that, from an open position of 70 degrees, the door will take at least 3 seconds to move to a point 3 inches from the latch, measured to the leading edge of the door. |
| I. | Keying Conference: Conduct conference at Project site to comply with requirements in Section 013100 "Project Management and Coordination." In addition to Owner, Construction Manager, Contractor, and Architect, conference participants shall also include Installer's Architectural Hardware Consultant and Owner's security consultant. Incorporate keying conference decisions into final keying schedule after reviewing door hardware keying system including, but not limited to, the following: <ol style="list-style-type: none">1. Function of building, flow of traffic, purpose of each area, degree of security required, and plans for future expansion.2. Preliminary key system schematic diagram.3. Requirements for key control system.4. Requirements for access control.5. Address for delivery of keys. |
| J. | Preinstallation Conference: Conduct conference at Project site. <ol style="list-style-type: none">1. Review and finalize construction schedule and verify availability of materials, Installer's personnel, equipment, and facilities needed to make progress and avoid delays.2. Inspect and discuss preparatory work performed by other trades.3. Inspect and discuss electrical roughing-in for electrified door hardware.4. Review sequence of operation for each type of electrified door hardware.5. Review required testing, inspecting, and certifying procedures. |

DIVISION 8 – OPENINGS

- | Section Number | Title |
|----------------|--|
| 1.7 | DELIVERY, STORAGE, AND HANDLING <ul style="list-style-type: none">A. Inventory door hardware on receipt and provide secure lock-up for door hardware delivered to Project site.B. Tag each item or package separately with identification coordinated with the final door hardware schedule, and include installation instructions, templates, and necessary fasteners with each item or package.C. Deliver keys and permanent cores to Owner by registered mail or overnight package service. |
| 1.8 | COORDINATION <ul style="list-style-type: none">A. Coordinate layout and installation of floor-recessed door hardware with floor construction. Cast anchoring inserts into concrete.B. Installation Templates: Distribute for doors, frames, and other work specified to be factory prepared. Check Shop Drawings of other work to confirm that adequate provisions are made for locating and installing door hardware to comply with indicated requirements.C. Security: Coordinate installation of door hardware, keying, and access control with Owner's security consultant.D. Electrical System Roughing-In: Coordinate layout and installation of electrified door hardware with connections to power supplies and building safety and security systems.E. Existing Openings: Where hardware components are scheduled for application to existing construction or where modifications to existing door hardware are required, field verify existing conditions and coordinate installation of door hardware to suit opening conditions and to provide proper door operation. |
| 1.9 | WARRANTY <ul style="list-style-type: none">A. Special Warranty: Manufacturer's standard form in which manufacturer agrees to repair or replace components of door hardware that fail in materials or workmanship within specified warranty period.<ul style="list-style-type: none">1. Failures include, but are not limited to, the following:<ul style="list-style-type: none">a. Structural failures including excessive deflection, cracking, or breakage.b. Faulty operation of doors and door hardware.c. Deterioration of metals, metal finishes, and other materials beyond normal weathering and use.2. Warranty Period: Three years from date of Substantial Completion, unless otherwise indicated. |

DIVISION 8 – OPENINGS

Section Number	Title
	a. Locks: Ten (10) years from date of Substantial Completion.
	b. Electrified Locks: Two (2) years from date of Substantial Completion.
	c. Exit Devices: Five (5) years from date of Substantial Completion.
	d. Manual Closers: Thirty (30) years from date of Substantial Completion.

PART 2 - PRODUCTS

2.1 SCHEDULED DOOR HARDWARE

- A. Provide door hardware for each door as scheduled in Part 3 "Door Hardware Schedule" Article to comply with requirements in this Section.
 - 1. Door Hardware Sets: Provide quantity, item, size, finish or color indicated, and products equivalent in function and comparable in quality to named products.
 - 2. Sequence of Operation: Provide electrified door hardware function, sequence of operation, and interface with other building control systems indicated.
- B. Designations: Requirements for design, grade, function, finish, size, and other distinctive qualities of each type of door hardware are indicated in Part 3 "Door Hardware Schedule" Article. Products are identified by using door hardware designations, as follows:
 - 1. Named Manufacturers' Products: Manufacturer and product designation are listed for each door hardware type required for the purpose of establishing minimum requirements. Manufacturers' names are abbreviated in Part 3 "Door Hardware Schedule" Article.
 - 2. References to BHMA Designations: Provide products complying with these designations and requirements for description, quality, and function.

2.2 HINGES

- A. Hinges: BHMA A156.1. Provide template-produced hinges for hinges installed on hollow-metal doors and hollow-metal frames.
 - 1. IVES Hardware; an Allegion company
 - a. Heavy weight ball bearing hinges or standard weight hinges as required in 652 finish.
 - b. Provide 630 finish at out swinging exterior doors.

2.3 CONTINUOUS HINGES

- A. Continuous Hinges: BHMA A156.26; minimum 0.120-inch- thick, hinge leaves with minimum overall width of 4 inches; fabricated to full height of door and frame and to template screw locations; with components finished after milling and drilling are complete.
- B. Continuous, Gear-Type Hinges: Extruded-aluminum, pinless, geared hinge leaves joined by a continuous extruded-aluminum channel cap; with concealed, self-lubricating thrust bearings.
 - 1. IVES Hardware; an Allegion company

DIVISION 8 – OPENINGS

Section Number	Title
	<ul style="list-style-type: none">a. 224HD Geared continuous hinges – UL type at rated doorsb. Provide at all exterior entry and high abuse areas. All athlete area, performing arts, cafeteria doors, restrooms and all other doors over 48”.
2.4	MECHANICAL LOCKS AND LATCHES
	<ul style="list-style-type: none">A. Cylindrical Locksets: BHMA A156.13; Operational Grade 1; stamped steel case with steel or brass parts;<ul style="list-style-type: none">1. Schlage Commercial Lock Division; an Allegion company. Owner’s request.<ul style="list-style-type: none">a. ND Series with Rhodes Levers in 626 finish, BD (less the small 7 pin removable core format)b. All locks to be supplied with Vandlgard feature.B. Mortise Locksets: BHMA A156.12; Operational Grade 1; constructed of solid stainless steel<ul style="list-style-type: none">1. Schlage Commercial Lock Division; an Allegion company. Owner’s request.<ul style="list-style-type: none">a. L Series with 06 Levers, N escutcheon in 626 finishb. LV9071 x XL12-751 on all classroomsc. LV9050 office function with L583-363 inside thumb turn on all office doors.d. All locks to be supplied with Vandlgard feature.e. NO MORTISE LOCKS ALLOWED ON NEW CONSTRUCTION UNLESS APPROVED BY NAU.C. Deadlocks: BHMA A156.12; Operational Grade 1; constructed of solid stainless steel<ul style="list-style-type: none">1. Schlage Commercial Lock Division; an Allegion company. Owner’s request.<ul style="list-style-type: none">a. L400 series, 626 finishD. Cylinders:<ul style="list-style-type: none">1. Schlage Commercial Lock Division; an Allegion company. Owner’s request.<ul style="list-style-type: none">a. Rim and Morise cylinders, 626 finish, for small 7 pin removable core format.
2.5	ELECTROMECHANICAL LOCKS
	<ul style="list-style-type: none">A. Electromechanical Locks: BHMA A156.25; Grade 1; motor or solenoid driven; mortise deadlocking latchbolt; with strike that suits frame.<ul style="list-style-type: none">1. Schlage Commercial Lock Division; an Allegion company. Owner’s request.<ul style="list-style-type: none">a. Request-to-Exit built in to the inside lever
2.6	SELF-CONTAINED ELECTRONIC LOCKS
	<ul style="list-style-type: none">A. Self-Contained Electronic Locks: BHMA A156.25, mortise; with internal, battery-powered, self-contained electronic locks; consisting of complete lockset, motor-driven lock mechanism, and actuating device; enclosed in zinc-dichromate-plated, wrought-steel case, and strike that suits frame. Provide key override, low-battery detection and

DIVISION 8 – OPENINGS

- | Section Number | Title |
|----------------|--|
| | warning, LED status indicators, and ability to program at the lock. |
| | 1. Schlage Commercial Lock Division; an Allegion company. |
| 2.7 | AUTOMATIC AND SELF-LATCHING FLUSH BOLTS |
| | A. Automatic and Self-Latching Flush Bolts: BHMA A156.16; minimum 3/4-inch throw; designed for mortising into door edge. |
| | 1. IVES Hardware; an Allegion company. |
| 2.8 | EXIT DEVICES AND AUXILIARY ITEMS |
| | A. Exit Devices and Auxiliary Items: BHMA A156.3. |
| | 1. Von Duprin; an Allegion company |
| | a. CD99 series rim panic exit devices in 626 finish on non-rated openings. |
| | b. 99L-F-2 series rim panic exit devices in 626 finish on rated openings with 996L break-away levers. |
| | c. Exterior doors requiring exit hardware must have cylinder dogging feature (CD). |
| | d. Where applicable use the 9949 cable exit device |
| | e. Mullions – KR9954 key removable mullions on both rated and non-rated doors. |
| 2.9 | PERMANENT CORES |
| | A. Permanent cores: Tumbler type, constructed from brass or bronze, stainless steel, or nickel silver. |
| | 1. Best Locks, a Stanley Security Company |
| | a. Small Format 7 pin removable core |
| | b. D, E, J, K, L, M, F, G, H, Q, WC, WG, TD, SC, WH and TB keyways. |
| | c. Provide construction cores that are replaceable by permanent cores. |
| 2.10 | KEYING |
| | A. Keying System: |
| | 1. Best Locks, a Stanley Security Company |
| | a. All cores to be keyed to the existing NAU Grand Master Key System. Please contact NAU Lock shop to determine the keyway to be used on each project. |
| | B. Keys: |
| | 1. Stamping: Permanently inscribe each key with a visual key control number and include the following notation: |
| | a. Notation: "DO NOT DUPLICATE." |
| | 2. Quantity: In addition to one extra key blank for each lock, provide the following: |
| | a. Cylinder Change Keys: Three. |
| | b. Master Keys: Three |
| | c. Control Key: Two |
| | d. Construction Operating Keys: Ten |
| | e. Construction Control Key: Three |

DIVISION 8 – OPENINGS

- | Section Number | Title |
|----------------|---|
| 2.11 | KEY CONTROL SYSTEM |
| A. | Key Control Cabinet: BHMA A156.5; metal cabinet with baked-enamel finish; containing key-holding hooks, labels, 2 sets of key tags with self-locking key holders, key-gathering envelopes, and temporary and permanent markers; with key capacity of 150 percent of the number of locks. |
| 1. | Multiple-Drawer Cabinet: Cabinet with drawers equipped with key-holding panels and key envelope storage, and progressive-type ball-bearing suspension slides. Include single cylinder lock to lock all drawers. |
| B. | Key Lock Boxes: Designed for storage of two keys, with tamper switches to connect to intrusion detection system. |
| 1. | Manufacturers: Subject to compliance with requirements, provide products by the following: |
| a. | Knox Company. |
| 2.12 | SURFACE CLOSERS |
| A. | Surface Closers: BHMA A156.4; rack-and-pinion hydraulic type with adjustable sweep and latch speeds controlled by key-operated valves and forged-steel main arm. Comply with manufacturer's written recommendations for size of door closers depending on size of door, exposure to weather, and anticipated frequency of use. Provide factory-sized closers, adjustable to meet field conditions and requirements for opening force. |
| 1. | LCN Closers; an Allegion company. |
| a. | 4040XP Series EDA (Extra Heavy Duty Arm) surface mounted |
| b. | Powder coated aluminum finish (689). |
| c. | Spring Cush Arms (SCUSH) allowed on 90 degree openings. |
| d. | Hold Open arms (H) can be used but must be approved by NAU. |
| e. | Gate Closers; 4000T Series – ST-3592 with SRI plating, with 4041-18 drop plate for mounting. |
| 2. | Allegion LCN 4040XP-EDA-TBWMS-ALUM closers must be installed by through-bolting the closer (with sexnuts) to the door with 1/4-20 hardware. The closer shoe must be attached to the frame by all five mounting points. In the case of aluminum frames, the shoe must be attached with 1/4-20 nutserts (aka rivetnuts) installed in the frame and using LCN 4040-61 Blade Stop Spacers. If necessary due to inadequate jamb reveal, the fifth attachment point will be accomplished by using LCN 4040-30 Cush Shoe Supports. |

Frames shall be the following or approved equal:

Section
Number

Title

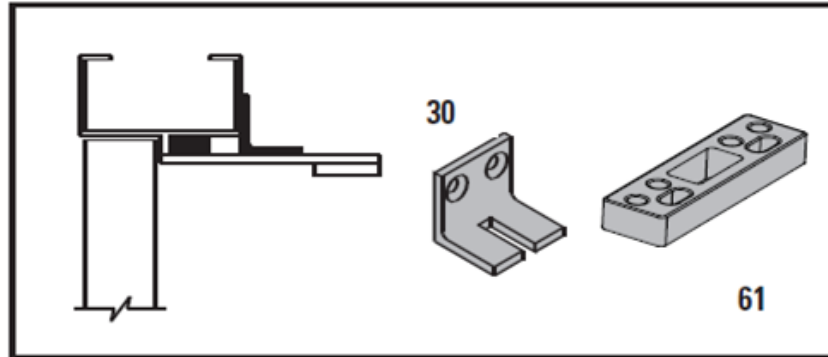

CUSH SHOE SUPPORT, 4040-30 provides anchorage for fifth screw used with CUSH arms, where reveal is less than 3 1/16" (78 mm).

BLADE STOP SPACER, 4040-61 required to lower parallel arm shoe to clear 1/2" (13 mm) blade stop.

2.13 CLOSER HOLDER RELEASE DEVICES

- A. Closer Holder Release Devices: BHMA A156.15; Grade 1; closer connected with separate or integral releasing and fire- or smoke-detecting devices. Door shall become self-closing on interruption of signal to release device. Automatic release is activated by smoke detection system.
 - 1. LCN Closers; an Allegion company.
 - a. 4040SE Series
 - b. Powder coated aluminum finish (689).

2.14 MECHANICAL STOPS AND HOLDERS

- A. Wall- and Floor-Mounted Stops: BHMA A156.16; aluminum base metal.
 - 1. IVES Hardware; an Allegion company
 - a. FS18S Heavy Duty floor type, black finish.
 - b. WS401 Series Convex or Concave wall stops in 626 finish

2.15 ELECTRONIC STOPS AND HOLDERS

- A. Wall Mount: BHMA A156
 - 1. LCN Closers; an Allegion company.
 - a. SEM7850 Die cast housing, standard profile recessed wall mount. Tri-Voltage design.

2.16 OVERHEAD STOPS AND HOLDERS

- A. Overhead Stops and Holders: BHMA A156.8.
 - 1. IVES Hardware; an Allegion company
 - a. 900 Series surface mounted, 626 finish.

DIVISION 8 – OPENINGS

- | Section Number | Title |
|----------------|--|
| 2.17 | METAL PROTECTIVE TRIM UNITS |
| | A. Metal Protective Trim Units: BHMA A156.6; fabricated from 0.050-inch-thick stainless steel; with manufacturer's standard machine or self-tapping screw fasteners. |
| | 1. IVES Hardware; an Allegion company |
| | a. 8400 Series, 12" high, beveled 4 sides, counter sunk screws, 630 finish |
| | b. Latch Guards on all exterior doors where required |
| 2.18 | DOOR GASKETING |
| | A. Door Gasketing: BHMA A156.22; air leakage not to exceed 0.50 cfm per foot of crack length for gasketing other than for smoke control, as tested according to ASTM E 283; with resilient or flexible seal strips that are easily replaceable and readily available from stocks maintained by manufacturer. |
| | 1. Zero International |
| | a. Brush Type seals are the preference |
| 2.19 | THRESHOLDS |
| | A. Thresholds: BHMA A156.21; fabricated to full width of opening indicated. |
| | 1. Zero International |
| 2.20 | FINISHES |
| | A. Provide finishes complying with BHMA A156.18 as indicated in door hardware schedule. |
| | B. Protect mechanical finishes on exposed surfaces from damage by applying a strippable, temporary protective covering before shipping. |
| | C. Appearance of Finished Work: Variations in appearance of abutting or adjacent pieces are acceptable if they are within one-half of the range of approved Samples. Noticeable variations in the same piece are not acceptable. Variations in appearance of other components are acceptable if they are within the range of approved Samples and are assembled or installed to minimize contrast. |

PART 3 - EXECUTION

- 3.1 EXAMINATION
- A. Examine doors and frames, with Installer present, for compliance with requirements for installation tolerances, labeled fire-rated door assembly construction, wall and floor construction, and other conditions affecting performance.
- B. Examine roughing-in for electrical power systems to verify actual locations of wiring connections before electrified door hardware installation.
- C. Proceed with installation only after unsatisfactory conditions have been corrected.

DIVISION 8 – OPENINGS

Section Number	Title
3.2	PREPARATION
	A. Steel Doors and Frames: For surface applied door hardware, drill and tap doors and frames according to ANSI/SDI A250.6.
	B. Wood Doors: Comply with DHI WDHS.5 "Recommended Hardware Reinforcement Locations for Mineral Core Wood Flush Doors."
3.3	INSTALLATION
	A. Mounting Heights: Mount door hardware units at heights indicated on Drawings unless otherwise indicated or required to comply with governing regulations. <ol style="list-style-type: none">1. Standard Steel Doors and Frames: ANSI/SDI A250.8.2. Custom Steel Doors and Frames: HMMA 831.3. Wood Doors: DHI WDHS.3, "Recommended Locations for Architectural Hardware for Wood Flush Doors."
	B. Install each door hardware item to comply with manufacturer's written instructions. Where cutting and fitting are required to install door hardware onto or into surfaces that are later to be painted or finished in another way, coordinate removal, storage, and reinstallation of surface protective trim units with finishing. Do not install surface-mounted items until finishes have been completed on substrates involved. <ol style="list-style-type: none">1. Set units level, plumb, and true to line and location. Adjust and reinforce attachment substrates as necessary for proper installation and operation.2. Drill and countersink units that are not factory prepared for anchorage fasteners. Space fasteners and anchors according to industry standards.
	C. Hinges: Install types and in quantities indicated in door hardware schedule but not fewer than the number recommended by manufacturer for application indicated or one hinge for every 30 inches of door height, whichever is more stringent, unless other equivalent means of support for door, such as spring hinges or pivots, are provided.
	D. Intermediate Offset Pivots: Where offset pivots are indicated, provide intermediate offset pivots in quantities indicated in door hardware schedule but not fewer than one intermediate offset pivot per door and one additional intermediate offset pivot for every 30 inches of door height greater than 90 inches.
	E. Lock Cylinders: Install construction cores to secure building and areas during construction period. <ol style="list-style-type: none">1. Replace construction cores with permanent cores as directed by Owner.2. Furnish permanent cores to Owner for installation.
	F. Boxed Power Supplies: Locate power supplies as indicated or, if not indicated, above

DIVISION 8 – OPENINGS

- | Section Number | Title |
|----------------|---|
| | accessible ceilings. Verify location with Architect. |
| | 1. Configuration: Provide least number of power supplies required to adequately serve doors with electrified door hardware. |
| | G. Thresholds: Set thresholds for exterior doors and other doors indicated in full bed of sealant complying with requirements specified in Section 079200 "Joint Sealants." |
| | H. Stops: Provide floor stops for doors unless wall or other type stops are indicated in door hardware schedule. Do not mount floor stops where they will impede traffic. |
| | I. Perimeter Gasketing: Apply to head and jamb, forming seal between door and frame. |
| | J. Meeting Stile Gasketing: Fasten to meeting stiles, forming seal when doors are closed. |
| | K. Door Bottoms: Apply to bottom of door, forming seal with threshold when door is closed. |
| 3.4 | ADJUSTING |
| | A. Initial Adjustment: Adjust and check each operating item of door hardware and each door to ensure proper operation or function of every unit. Replace units that cannot be adjusted to operate as intended. Adjust door control devices to compensate for final operation of heating and ventilating equipment and to comply with referenced accessibility requirements. |
| | 1. Spring Hinges: Adjust to achieve positive latching when door is allowed to close freely from an open position of 30 degrees. |
| | 2. Electric Strikes: Adjust horizontal and vertical alignment of keeper to properly engage lock bolt. |
| | 3. Door Closers: Adjust sweep period to comply with accessibility requirements and requirements of authorities having jurisdiction. |
| | B. Occupancy Adjustment: Approximately three months after date of Substantial Completion, Installer's Architectural Hardware Consultant shall examine and readjust each item of door hardware, including adjusting operating forces, as necessary to ensure function of doors, door hardware, and electrified door hardware. |
| 3.5 | CLEANING AND PROTECTION |
| | A. Clean adjacent surfaces soiled by door hardware installation. |
| | B. Clean operating items as necessary to restore proper function and finish. |
| | C. Provide final protection and maintain conditions that ensure that door hardware is without damage or deterioration at time of Substantial Completion. |

DIVISION 8 – OPENINGS

Section
Number

Title

08 80 00

GLAZING

08 81 00

Glass Glazing

Dual pane 1" insulated glass at a minimum shall be specified on all exterior windows.

Side lights and/or door lights to be tempered float glass.

All glass within contact by pedestrian traffic to be tempered.

Individual windows or window assemblies shall be designed to easily accommodate washing of the exterior surface.

Exterior ledges of window openings shall be designed to allow proper drainage away from the window assembly, 1/2" per foot minimum.

All window assemblies shall be fully weatherstripped and gasketed.

All glass types shall be a local stock item to eliminated replacement delays.

*** * * END OF SECTION * * ***